



Rocker Arms — Manual Inspection

1. Remove the ignition coil covers (see page 6-15 ('91-'93) or ('94-'96)).
2. Remove the ignition coils (see page 6-15 ('91-'93) or ('94-'96)).
3. Remove the cylinder head covers.

NOTE: Refer to pages 6-47 ('91-'93) or ('94-'96), 48 ('91-'93) or ('94-'96) when installing the cylinder head cover.

4. Set the No. 1 piston at top dead center (TDC) (see page 6-19 ('91-'93) or ('94-'96)).
5. Push the mid rocker arms on the No. 1 cylinder manually.
6. Check that the mid rocker arms move independently of the primary and secondary rocker arms.

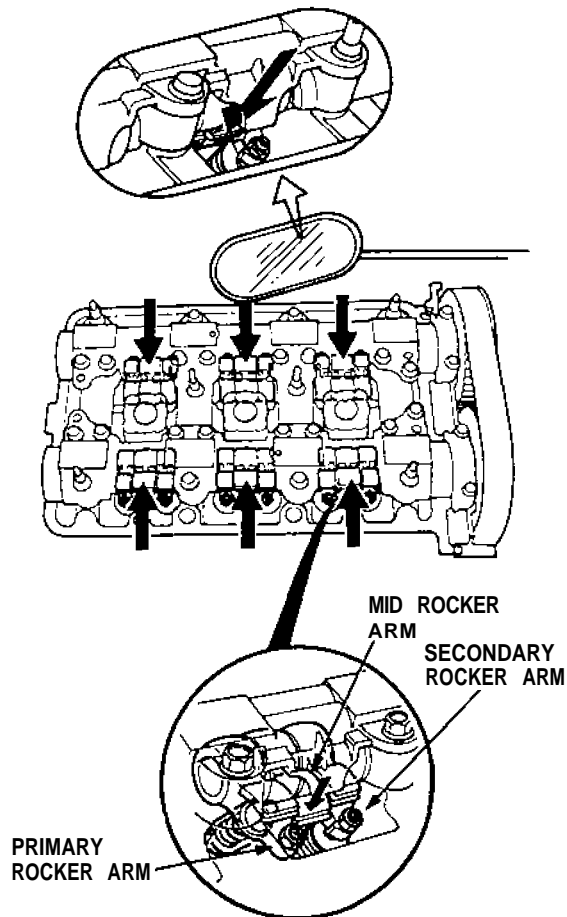

7. Check the mid rocker arms of each cylinder at TDC.
 - If a mid rocker arm does not move, remove the mid, primary and secondary rocker arms as an assembly and check that the pistons in the mid and primary rocker arms move smoothly.
 - Replace the rocker arms as an assembly if there is any abnormality.

Rocker Arms — Inspection Using Special Tools

CAUTION:

- Before using the special tool, make sure that the air pressure gauge on the air compressor indicates over 250 kPa (2.5 kg/cm², 36 psi).
- Inspect the valve clearance before rocker arm inspection.
- Cover the timing belt with a shop towel to prevent getting oil on the belt.
- Check the mid rocker arms of each cylinder at TDC.

1. Plug the relief hole with the special tool as shown.

Front cylinder head:

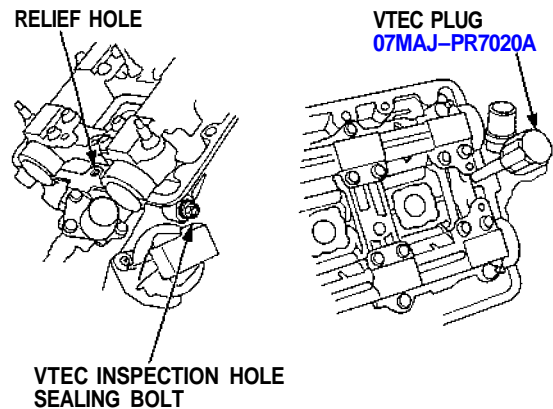

Rear cylinder head:

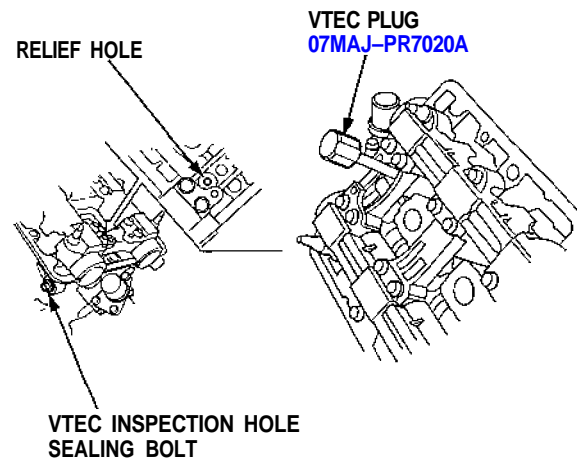

(cont'd)