



## Removal

### NOTE:

- Before removing the belt, turn the crankshaft pulley so the No. 8 piston is at top dead center (TDC) (see page 6-19 ('91-'93) or ('94-'96))
- Inspect the water pump after removing the timing belt (see page 10-11).
- If it is to be reused, mark the direction of rotation on the belt.

1. Disconnect the battery negative terminal first, then the positive terminal,
2. Remove the right rear wheel/tire.
3. Remove the engine oil cooler base assembly-

NOTE: Do not disconnect the hoses.

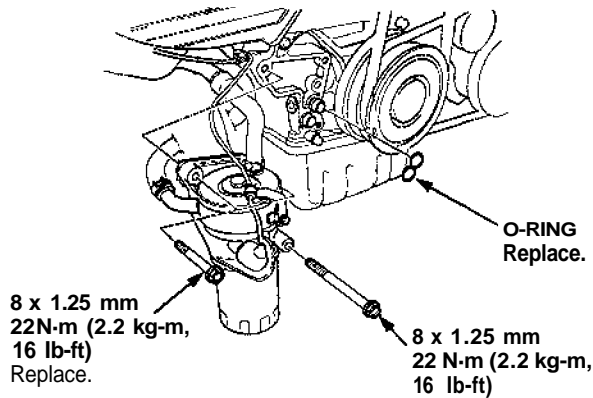

4. Remove the strut brace (see page 5-3 ('91-'93) or ('94-'96))
5. Remove the intake manifold plate and top cover (see page 6-25 ('91-'93) or ('94-'96))

4. Remove the ignition coil covers, the injector cover and the wire harness covers.
5. Remove the ignition coils and the connectors.

### NOTE:

- There are front and rear ignition coils and covers. They can be identified by the mark FF (front) or RR (rear) printed on them.
- When installing front and rear ignition coil covers, attach a rubber seal to the intake side.

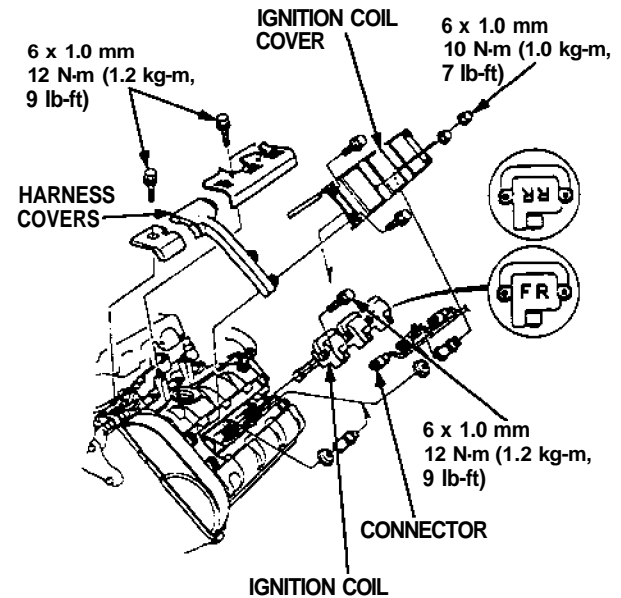

6. Remove the expansion tank.

NOTE: Do not disconnect water hoses.

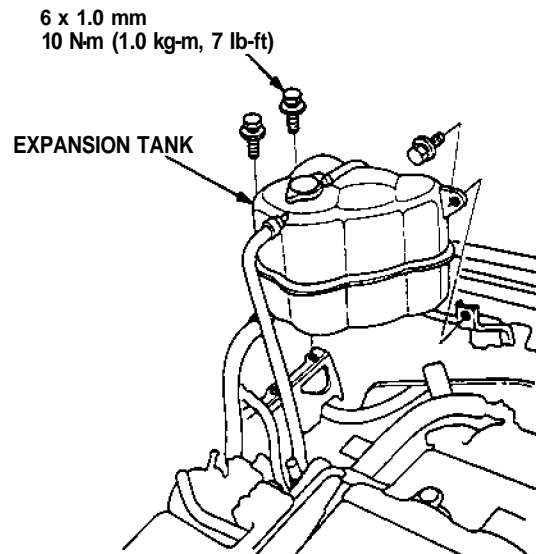

(cont'd)

# Timing Belt

## Removal (cont'd)

7. Remove the breather hose and the air cleaner housing (see page 6-25 ('91-'93) or ('94-'96) )
8. Disconnect the alternator connector and the terminal.
9. Remove the cover, adjusting bolt, the mounting bolt and mounting nut, then remove the alternator belt and the alternator.

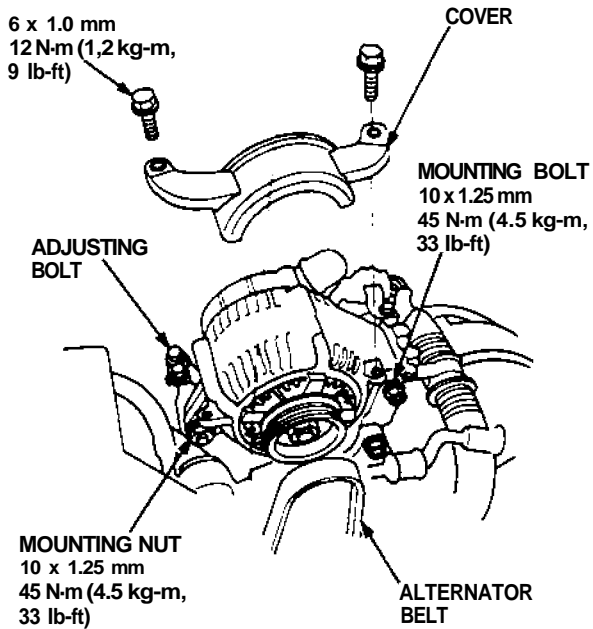

10. Remove the cylinder head covers.
  - Refer to page 6-47 ('91-'93) or ('94-'96) when installing.
11. Remove the two bolts from the side engine mount near the alternator bracket. Pivot the mounting bracket into the housing of the body.

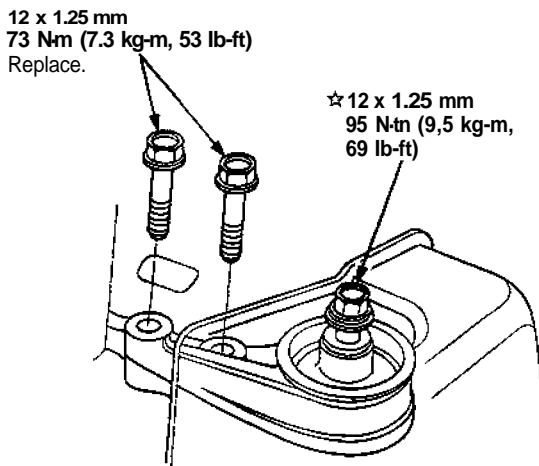

☆: CORROSION RESISTANT BOLT

12. Remove the transmission mount (see page 5-10 ('91-'93) or ('94-'96) transmission mount
13. Install a brace under the engine, then tilt the engine approximately 5° using a jack.

NOTE: Make sure to place a cushion between the oil pan and the jack.

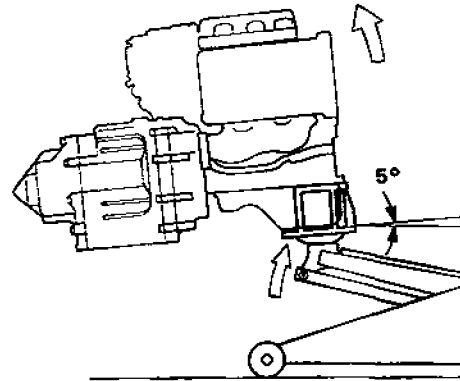

14. Remove the alternator bracket stiffener and dipstick pipe.

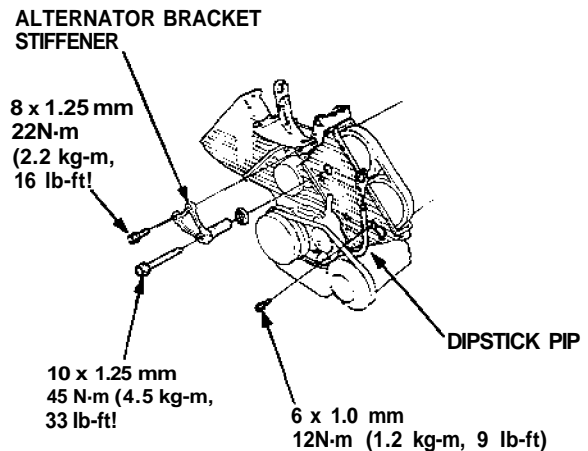



15. Loosen the idler pulley center nut and adjusting nut, then remove the air conditioning (A/C) compressor belt.

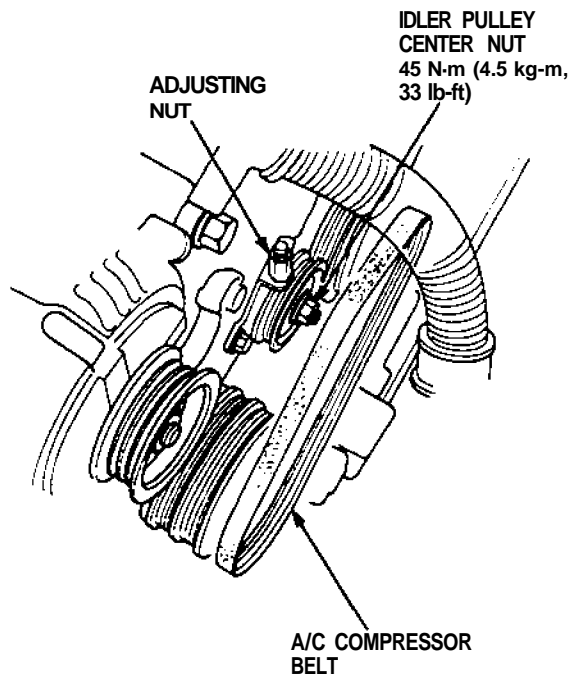

16. Remove the crankshaft pulley (see page 6-12 ('91-'93) or ('94-'96))
17. Remove the rubber seal from the adjusting bolt, then remove the middle covers and lower cover.

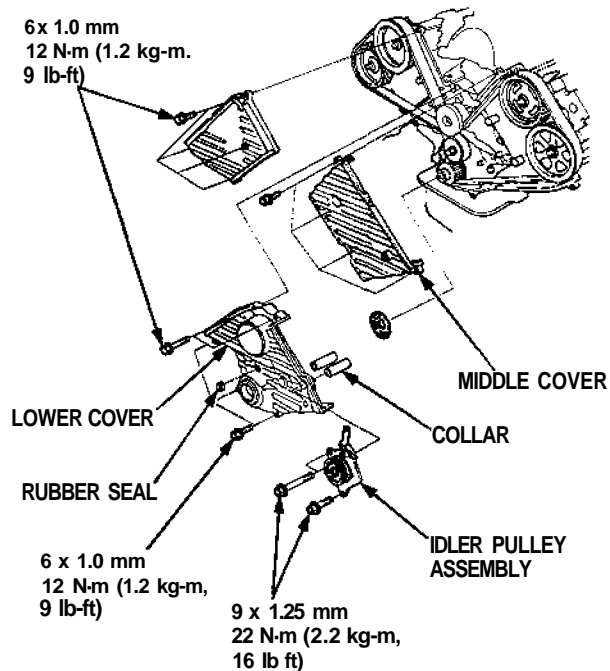

18. Loosen the adjusting bolt 180° turn. Push the tensioner to remove tension from the timing belt, then retighten the adjusting bolt.

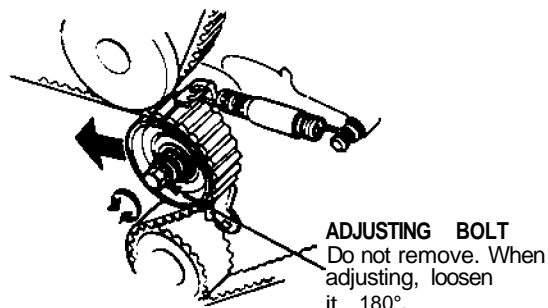

19. Remove the timing belt from the pulleys.