

Camshafts

Inspection

NOTE:

- Do not rotate the camshaft during inspection.
 - Remove the rocker arms and rocker shafts.
1. Put the camshafts, the camshaft holders and holder plates on the cylinder head, and then tighten the bolts to the specified torque.

NOTE: Apply clean engine oil to 8 mm bolt threads.
Specified torque:

- ① - ⑭ 8 mm x 1.25 mm bolts:
22N-m (2.2 kg-m, 16 lb-ft)
- ⑮ - ⑳ 6 mm x 1.0 mm bolts:
10N-m (1.0 kg-m, 7 lb-ft)

CAMSHAFT HOLDER BOLTS TORQUE SEQUENCE

FRONT:

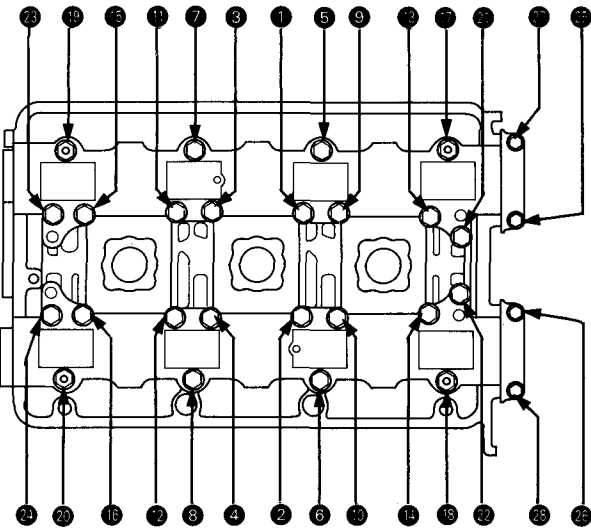

REAR:

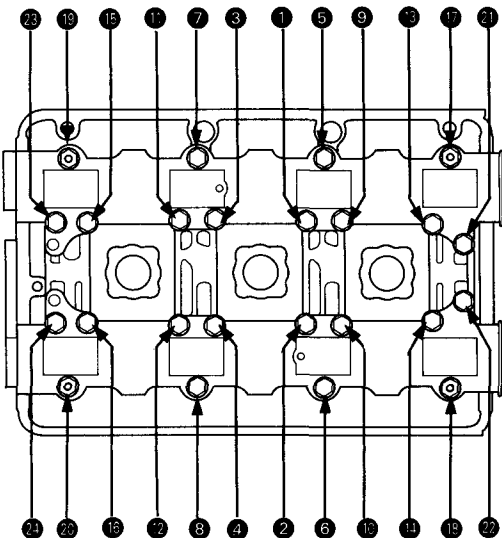

2. Seat the camshaft by pushing it toward the left end of cylinder head.
3. Zero the dial indicator against the left end, then push the camshaft back and forth, and read the end play.

Camshaft End Play:

Standard (New): 0.05—0.15 mm
(0.002—0.006 in)
Service Limit: 0.5 mm (0.02 in)

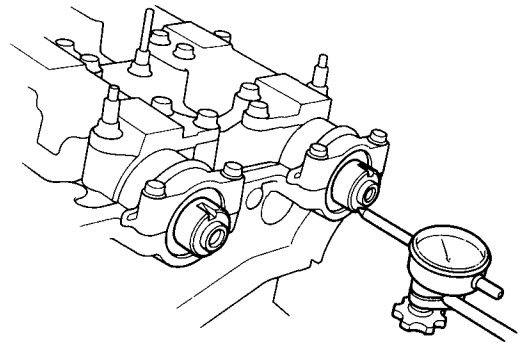

4. Remove the bolts, then remove the camshaft holders from the cylinder head.
 - Lift the camshaft out of the cylinder head, wipe it clean, then inspect the lift ramps. Replace the camshaft if lobes are pitted, scored, or excessively worn.
 - Clean the camshaft bearing surfaces in the cylinder head, then set the camshaft back in place.
 - Insert a plastigage strip across each journal.
5. Install the camshaft holders, and then tighten the bolts to the specified torque as shown in the left column on this page.
6. Remove the camshaft holders and measure widest portion of plastigage on each journal.

Camshaft-to-Holder Oil Clearance:

Standard (New): 0.050-0.089 mm
(0.002-0.004 in)
Service Limit: 0.15 mm (0.006 in)

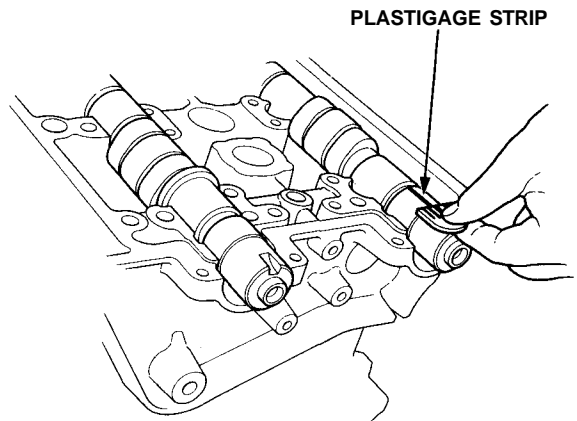

PLASTIGAGE STRIP



7. If camshaft-to-holder oil clearance is out of tolerance:

- And camshaft has already been replaced, you must replace the cylinder head.
- If camshaft has not been replaced, first check total runout with the camshaft supported on V-blocks.

Camshaft Total Runout:

Standard (New): 0.03 mm (0.0012 in) max.

Service Limit: 0.04 mm (0.0016 in)

Rotate camshaft while measuring

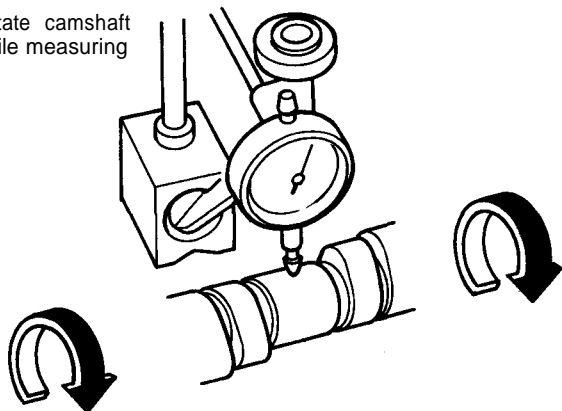

- If the total runout of the camshaft is within tolerance, replace the cylinder head.
- If the total runout is out of tolerance, replace the camshaft and recheck. If the oil clearance is still out of tolerance, replace the cylinder head.

8. Check cam lobe height wear.

Cam Lobe Height Standard (New):

M/T

	INTAKE	EXHAUST
PRIMARY	37.086 mm (1.4601 in)	36.559 mm (1.4393 in)
MID	38.037 mm (1.4975 in)	37.398 mm (1.4724 in)
SECONDARY	37.326 mm (1.4695 in)	36.741 mm (1.4465 in)

A/T

	INTAKE	EXHAUST
PRIMARY	37.266 mm (1.4672 in)	36.559 mm (1.4393 in)
MID	37.655 mm (1.4825 in)	37.398 mm (1.4724 in)
SECONDARY	37.504 mm (1.4765 in)	36.741 mm (1.4465 in)

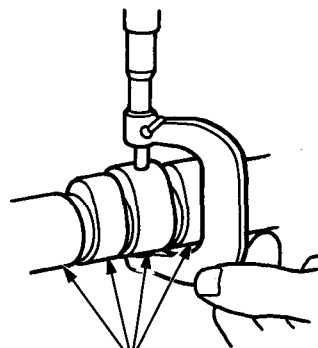

Check this area for wear.

Cam position

P: Primary M: Mid S: Secondary

