



Cylinder Heads

Installation

Install the cylinder heads in the reverse order of removal:

- Always use new head gaskets.
 - Cylinder heads and engine block surface must be clean.
 - Turn the crankshaft so that No. 1 piston is at TDC (see page 6-19).
 - Do not use the middle cover and lower cover for storing removed items.
 - Clean the middle cover and lower cover before installation.
1. Install the front and rear exhaust manifolds to each cylinder head, then tighten the self-locking nuts in a crisscross pattern in two or three steps, beginning with the inner nut.
 - Apply oil to the self-locking nut threads.
 - Always use new exhaust manifold gaskets.

2. Install the exhaust manifold covers.

Front:

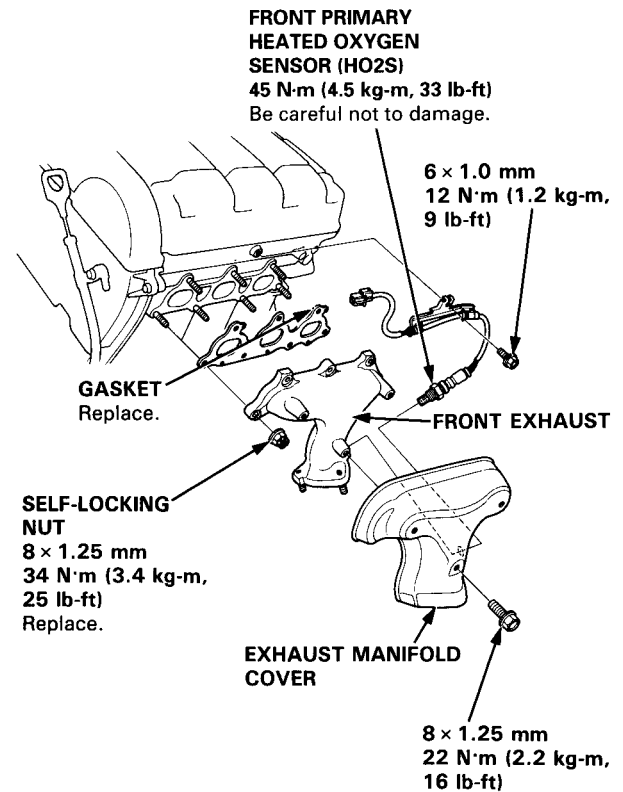

(cont'd)

Cylinder Heads

Installation (cont'd)

Rear:

8 x 1.25 mm
22 N-m (2.2 kg-m,
16 lb-ft)

REAR PRIMARY
HO2S
45 N-m (4.5 kg-m,
33 lb-ft)

Be careful not to damage.

GASKET
Replace.

REAR EXHAUST
MANIFOLD

EXHAUST
MANIFOLD
COVER

SELF-LOCKING NUT
8 x 1.25 mm
34 N-m (3.4 kg-m,
25 lb-ft)
Replace.

3. Install the cylinder heads on the engine block. The cylinder head dowel pins and the head oil control orifice must be aligned.
- Always use a new cylinder head gasket.
 - Clean the oil control orifice before installing.

CYLINDER HEAD
GASKET
Replace.

OIL CONTROL
ORIFICES
Clean.

CYLINDER HEAD
GASKET
Replace.

DOWEL
PIN

DOWEL PIN

O-RING
Replace.

DOWEL
PINS

4. Tighten the cylinder head bolts sequentially in two or three steps.
- Apply clean engine oil to the bolt threads and washer contact surfaces.

Specified Torque

11 x 1.5 mm

78 N-m (7.8 kg-m, 56 lb-ft)

NOTE: We recommend using a beam-type torque wrench. When using a preset-type torque wrench, be sure to tighten slowly and not to over-tighten.

CYLINDER HEAD BOLTS TORQUE SEQUENCE

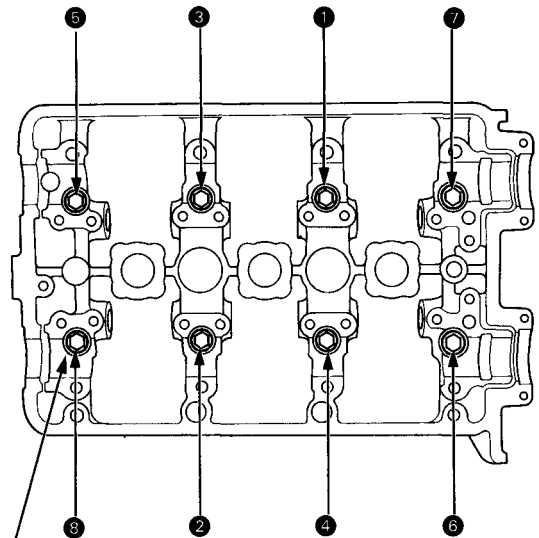

CYLINDER HEAD BOLT

11 x 1.5 mm

78 N-m (7.8 kg-m, 56 lb-ft)

Apply clean engine oil to the
bolt threads and washer
surfaces.