

Troubleshooting

Troubleshooting Procedures

I. How To Begin Troubleshooting

When the Malfunction Indicator Lamp (MIL) has been reported on, or there is a driveability problem, use the appropriate procedure below to diagnose and repair the problem.

A. When the MIL has come on:

1. Connect the Honda PGM Tester or an OBD-II scan tool to the 16P Data Link Connector (DLC) located under the glove box behind a removable cover.
2. Turn the ignition switch ON.
3. Honda PGM Tester: Begin troubleshooting as indicated by the tester. The DTC troubleshooting flowcharts are not needed with the tester; follow the tester's prompts.

OBD-II scan tool: Check the DTC and note it. Also check and note the freeze frame data. Refer to the Diagnostic Trouble Code Chart and begin troubleshooting.

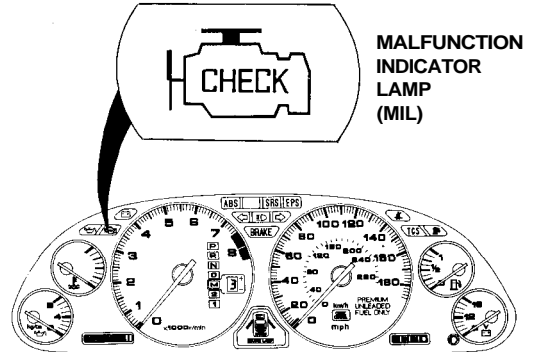

NOTE:

- See the OBD-II scan tool or Honda PGM Tester user's manuals for specific operating instructions.
- The scan tool or tester can read the Diagnostic Trouble Codes (DTC), freeze frame data, current data, and other Engine Control Module (ECM) data.
- Freeze frame data indicates the engine conditions when the first malfunction, misfire or fuel trim malfunction was detected. It can be useful information when troubleshooting.

B. When the MIL has not come on, but there is a driveability problem, refer to the Symptom Chart on page [11-42](#).

C. DTCs will be indicated by the blinking of the Malfunction Indicator Lamp (MIL) with the SCS service connector connected.

- Connect the SCS service connector to Service Check Connector as shown. (The 2P Service Check Connector is located under the dash on the passenger's side of the car.) Turn the ignition switch on.

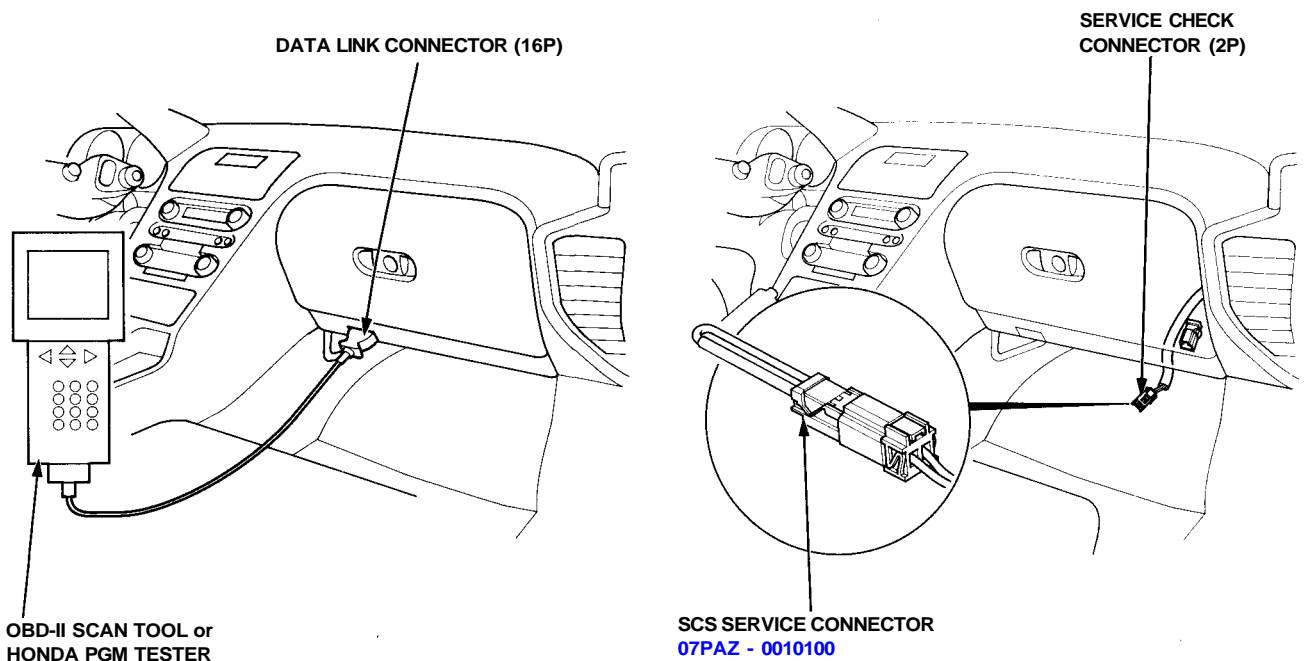



II. Engine Control Module (ECM) Reset Procedure

Either of the following actions, will reset the ECM.

- Using the OBD-II scan tool or Honda PGM Tester to clear the ECM's memory.

NOTE: See the OBD-II scan tool or Honda PGM Tester user's manuals for specific operating instructions.

- Turn the ignition switch OFF. Remove the CLOCK (7.5 A) fuse from the under-hood fuse/relay box for 10 seconds.

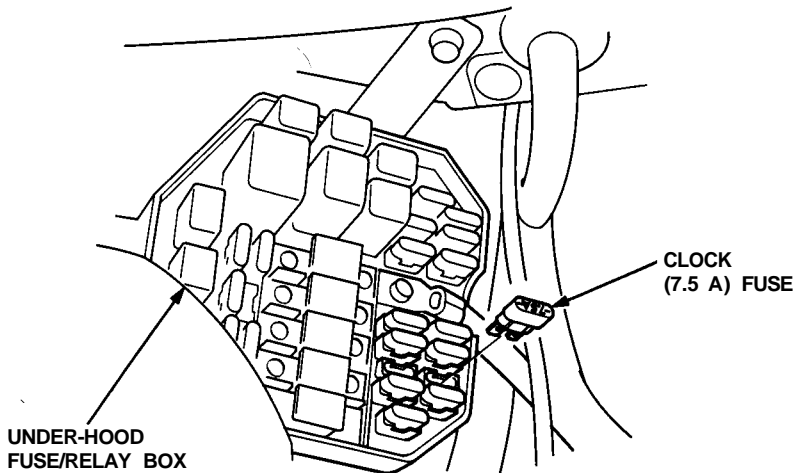

III. Final Procedure (this procedure must be done after any troubleshooting)

1. Remove the SCS Service Connector if it is connected.

NOTE: If the SCS service connector is connected and there are no DTCs stored in the ECM, the MIL will stay on when the ignition switch is turned on.

2. Do the ECM Reset Procedure.
3. Turn the ignition switch OFF.
4. Disconnect the OBD-II scan tool or Honda PGM Tester from the Data Link Connector,

(cont'd)

Troubleshooting

Troubleshooting Procedures (cont'd)

If the inspection for a particular code requires voltage or resistance checks at the ECM connectors, remove the bulkhead panels. Unbolt the ECM. Check the system according to the procedure described for the appropriate code(s) listed on the following pages.

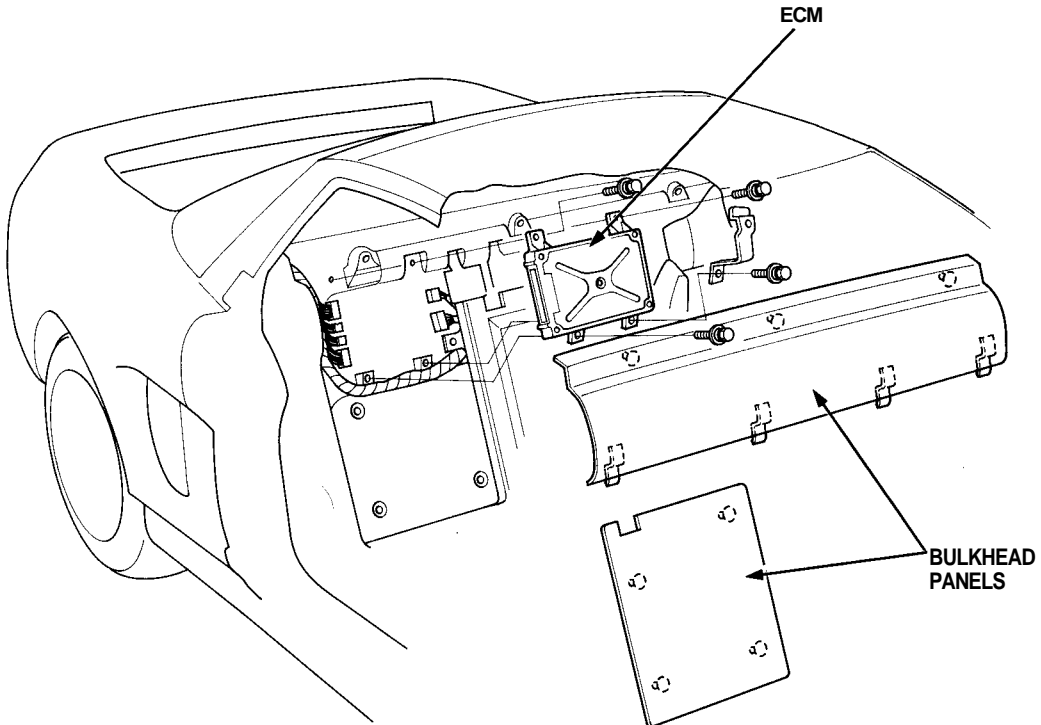

How to Use the Backprobe Sets

Connect the backprobe adapters to the stacking patch cords, and connect the cords to a multimeter. Using the wire insulation as a guide for the contoured tip of the backprobe adapter, gently slide the tip into the connector from the wire side until it comes in contact with terminal end of the wire.

DIGITAL MULTIMETER
(Commercially available) or
KS-AHM-32-003

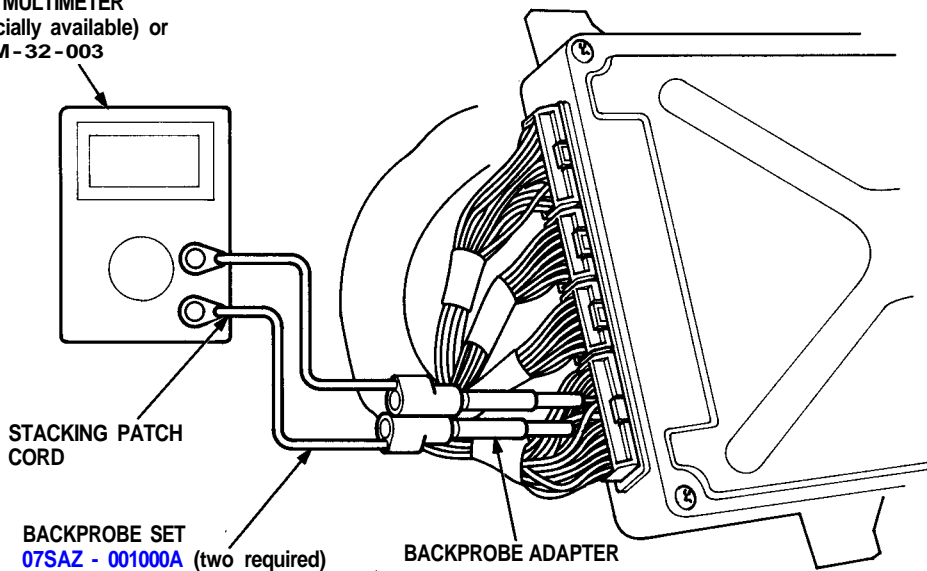



CAUTION:

- Puncturing the insulation on a wire can cause poor or intermittent electrical connections.
- Bring the tester probe into contact with the terminal from the connector side of wire harness connectors in the engine compartment. For female connectors, just touch lightly with the tester probe and do not insert the probe.

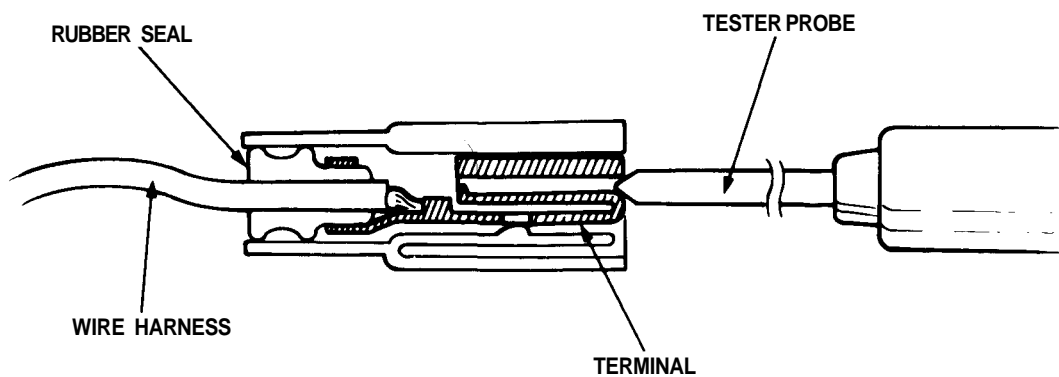

(cont'd)

Troubleshooting

Troubleshooting Procedures (cont'd)

Symptom Chart

Listed below are symptoms and probable causes for problems that DO NOT cause the Malfunction Indicator Lamp (MIL) to come on.

If the MIL was reported on, go to page [11-38](#).

Troubleshoot each probable cause in the order listed (from left to right) until the symptom is eliminated.

The probable cause and troubleshooting page reference can be found on next page.

SYMPTOM	PROBABLE CAUSE
Engine will not start	4, 2, 3, 5, 19, 13, 1
Hard starting	2, 4, 10, 12, 18
Cold fast idle too low	7, 6
Cold fast idle too high	7, 9, 8
Idle speed fluctuates	7, 9, 8
Misfire or rough running	Troubleshoot for misfire on pages 11-90 , 11-94
Low power	2, 8, 9, 11, 16, 15, 17, 10
Engine stalls	2, 4, 10, 19, 7, 5, 14

Other Probable Causes:

- Engine will not start
 - Compression
 - Engine locked up
 - Timing belt
 - Starting system
 - Overheating
 - Battery



Probable Cause List

Probable Cause	Page	System
1	11-61, 11-62	Engine Control Module (ECM)
2	11-132, 11-139	Fuel pressure and fuel pump relay
3	11-143	PGM-FI main relay
4	Section 23	Ignition system
5	See DTC chart	Crankshaft Position/Cylinder Position sensor circuit
6	See DTC chart	Intake Air Temperature (IAT) sensor circuit
7	11-128	Idle speed adjustment
8	11-151	Throttle body
9	11-150	Throttle cable
10	See DTC chart	Manifold Absolute Pressure (MAP) sensor
11	See DTC chart	Throttle Position (TP) sensor
12	See DTC chart	Barometric pressure (BARO) sensor
13	11-121, 11-124	A/T gear position signal or clutch switch signal
14	11-126	Brake switch signal
15	11-149	Air Cleaner
16	11-154	Intake Air Bypass (IAB) control system and intake air pipe
17	11-159	Three Way Catalytic Converter (TWC)
18	11-167	Evaporative emission (EVAP) control
19	—	Contaminated fuel

(cont'd)

Troubleshooting

Troubleshooting Procedures (cont'd)

ECM Data

By connecting the OBD-II scan tool or the Honda PGM Tester to the 16P data link connector (DLC), various data can be retrieved from the ECM. The items listed in the table below conform to the SAE recommended practice.

The Honda PGM Tester also reads data beyond that recommended by SAE.

Understanding this data will help to find the causes of intermittent failures or engine problems.

NOTE:

- The "operating values" given below are approximate values and may be different depending on the environment and the individual car.
- Unless noted otherwise, "at idle speed" means idling with the engine completely warmed up, A/T in **P** or **N** position, M/T in neutral, and the A/C and all accessories turned off.

Data	Description	Operating Value	Freeze Data
Diagnostic Trouble Code (DTC)	If the ECM detects a problem, it will store it as a code consisting of one letter and four numbers. Depending on the problem, an SAE-defined code (P0xxx) or a Honda-defined code (P1xxx) will be output to the tester.	If no problem is detected, there is no output.	○
Engine Speed	The ECM computes engine speed from the signals sent from the Crankshaft Position sensor. This data is used for determining the time and amount of fuel injection.	Nearly the same as tachometer indication at idle speed: A/T: 780 ± 50 rpm M/T: 800 ± 50 rpm	○
Vehicle Speed	The ECM converts pulse signals from the Vehicle Speed Sensor (VSS) into speed data.	Nearly the same as speedometer indication	○
Manifold Absolute Pressure (MAP)	The absolute pressure created in the intake manifold by engine load and speed.	With engine stopped: Nearly the same as atmospheric pressure at idle speed: 24 – 37 kPa (180 – 280 mmHg, 7.1 – 11.0 inHg)	○
Engine Coolant Temperature (ECT)	The ECT sensor converts coolant temperature into voltage and signals the ECM. The sensor is a thermistor whose internal resistance changes with coolant temperature. The ECM uses the voltage signals from the ECT sensor to determine the amount of injected fuel.	With cold engine: Same as ambient temperature and IAT With engine warmed up: approx. 176 – 194°F (80 – 90°C)	○
Heated Oxygen Sensor (HO2S) (Bank 1, Sensor 1) (Bank 1, Sensor 2) (Bank 2, Sensor 1) (Bank 2, Sensor 2)	The Heated Oxygen Sensor detects the oxygen content in the exhaust gas and sends voltage signals to the ECM. Based on these signals, the ECM controls the air/fuel ratio. When the oxygen content is high (that is, when the ratio is leaner than the stoichiometric ratio), the voltage signal is lower. When the oxygen content is low (that is, when the ratio is richer than the stoichiometric ratio), the voltage signal is higher.	0.0 – 1.25 V At idle speed: about 0.1 – 0.9 V	○ (Sensor 1)



Data	Description	Operating Value	Freeze Data
HO2S Feedback Loop Status (Bank 1: Rear) (Bank 2: Front)	Loop status is indicated as "open" or "closed". Closed: Based on the HO2S output, the ECM determines the air/fuel ratio and controls the amount of injected fuel. Open: Ignoring HO2S output, the ECM refers to signals from the TP, MAP, and ECT sensors to control the amount of injected fuel.	At idle speed: closed	○
Short Term Fuel Trim (Bank 1: Rear) (Bank 2: Front)	The air/fuel ratio correction coefficient for correcting the amount of injected fuel when HO2S feedback is in the closed loop status. When the signal from the HO2S is weak, short term fuel trim gets higher, and the ECM increases the amount of injected fuel. The air/fuel ratio gradually gets richer, causing a higher HO2S output. Consequently, the short term fuel trim is lowered, and the ECM reduces the amount of injected fuel. This cycle keeps the air/fuel ratio close to the stoichiometric ratio when in closed loop status.	-30% - +43%	○
Long Term Fuel Trim (Bank 1: Rear) (Bank 2: Front)	Long term fuel trim is computed from short term fuel trim and indicates changes occurring in the fuel supply system over a long period. If long term fuel trim is higher than 1.00, the amount of injected fuel must be increased. If it is lower than 1.00, the amount of injected fuel must be reduced.	-19% - +25%	○
Intake Air Temperature (IAT)	The IAT sensor converts intake air temperature into voltage and signals the ECM. When intake air temperature is low, the internal resistance of the sensor increases, and the voltage signal is higher.	With cold engine: Same as ambient temperature and ECT	○
Throttle Position	Based on the accelerator pedal position, the opening angle of the throttle valve is indicated.	At idle: Approx. 10% At full throttle: Approx. 90%	○
Ignition Timing	The ignition advance angle is set by the ECM. The ECM matches ignition timing to the driving conditions.	At idle speed: $15 \pm 2^\circ$ BTDC with the SCS service connector connected.	×
Calculated Load Value (CLV)	CLV is the engine load calculated from the MAP data.	At idle speed: 15 - 35% At 2,500 rpm with no load: 12 - 30%	○