

Clutch Master Cylinder

Removal

1. Disconnect the clutch pipe from the clutch master cylinder.
2. Pry out the cotter pin, and pull the clevis pin out of the clevis.
3. Remove the nuts.

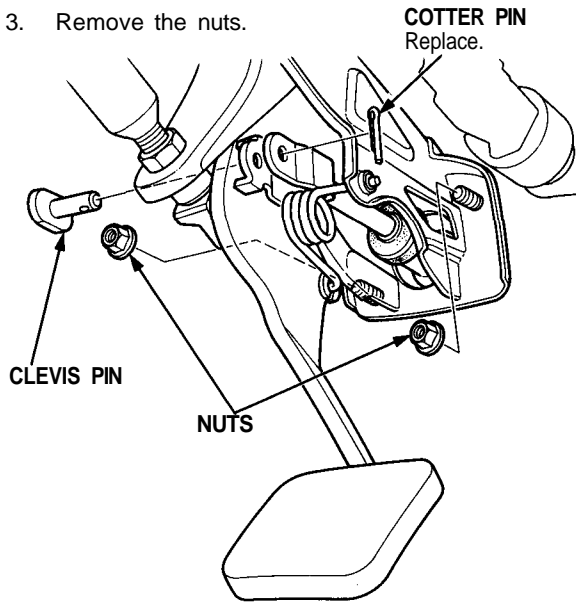

4. Remove the reservoir from the front compartment, then remove the clutch master cylinder.
5. Disconnect the reservoir hose from the clutch master cylinder, then remove the reservoir.

CAUTION:

- Avoid spilling brake fluid on paint as it may damage the finish.
- Plug the end of the clutch pipe and reservoir hose with a shop towel to prevent fluid from flowing out of the clutch pipe and reservoir hose after disconnecting.

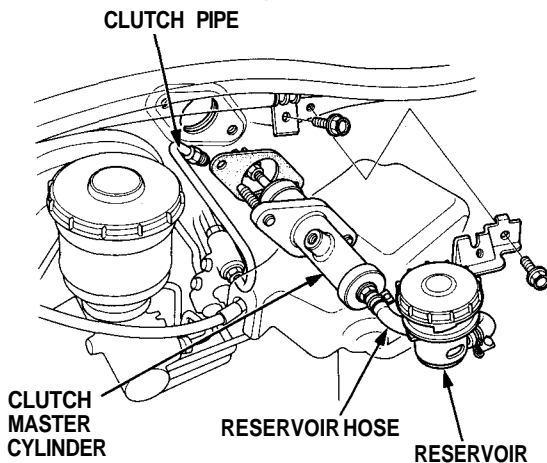

Installation

1. Install the clutch master cylinder in the reverse order of removal.

NOTE: Bleed the clutch hydraulic system (see page 12-6).

