

# Shift Fork, Synchro Sleeve

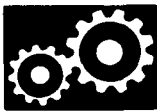

## Clearance Inspection

1. Measure the clearance between each shift fork and its matching synchro sleeve.

**Standard: 0.45-0.65 mm  
(0.018-0.026 in)**  
**Service Limit: 1.0 mm (0.039 in)**

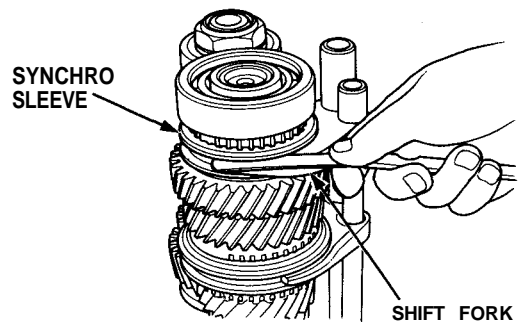

2. If the clearance exceeds the service limit, measure the width of the shift fork fingers.

**Standard:**

**1st/2nd Shift Fork: 8.9-9.0 mm  
(0.350-0.354 in)**

**3rd/4th Shift Fork: 7.4-7.5 mm  
(0.291 - 0.295 in)**

**5th Shift Fork: 6.4-6.5 mm  
(0.252-0.256 in)**

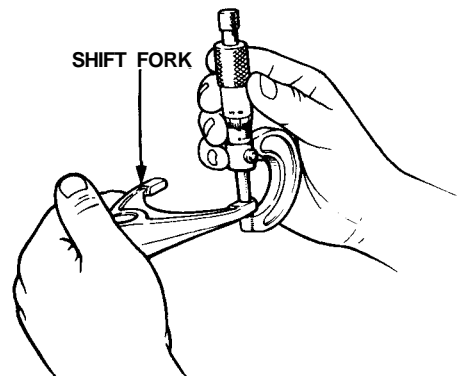

If the width of the shift fork fingers is less than the standard, replace the shift fork with a new one.  
If the width of the shift fork fingers is within the standard, replace the synchro sleeve with a new one.

**NOTE:** The synchro sleeve and synchro hub should be replaced as a set.