

Countershaft Assembly

Clearance Inspection

1. Measure the clearance between 2nd and 3rd gear.

Standard: **0.04-0.10 mm (0.002-0.004 in)**

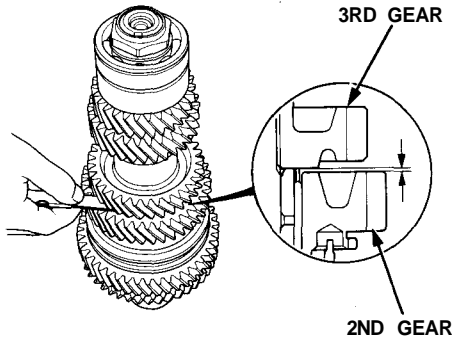

2. If the clearance exceeds the standard, select the appropriate spacer collar for the correct clearance from the chart below.

SPACER COLLAR

	Part Number	Thickness
A	23912-PR8-000	33.07-33.09 mm (1.3020-1.3028 in)
B	23913-PR8-000	33.03-33.05 mm (1.3004-1.3012 in)

3. Measure the clearance between 1st and reverse gear.

Standard: **0.04-0.10 mm (0.002-0.004 in)**

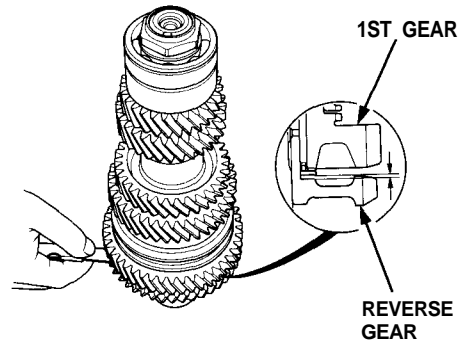

4. If the clearance exceeds the standard, select the appropriate thrust washer for the correct clearance from the chart below.

THRUST WASHER

	Part Number	Thickness
A	23921-PR8-000	1.42-1.44 mm (0.0559-0.0567 in)
B	23922-PR8-000	1.45-1.47 mm (0.0571-0.0579 in)
C	23923-PR8-000	1.48-1.50 mm (0.0583-0.0591 in)
D	23924-PR8-000	1.51-1.53 mm (0.0594-0.0602 in)
E	23925-PR8-000	1.54-1.56 mm (0.0606-0.0614 in)