

Preset Torque

Inspection

On-Car:

1. Lift up right rear wheel, and place the safety stand. (Lift and Support Points, see [section 1](#)).
2. Block the other three wheels.
3. Measure preset torque clockwise using a torque wrench as shown.

Standard: 60–140 N·m
(6–14 kg·m, 43–101 lb·ft)
Service Limits: 30 N·m (3 kg·m, 22 lb·ft)

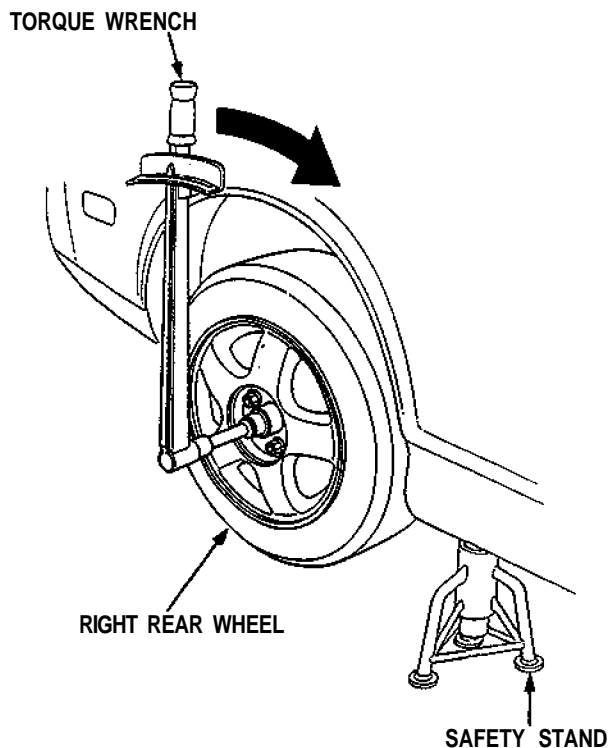

4. If preset torque is less than the service limit, replace the clutch discs with new ones.

NOTE: Adjust the thrust shim whenever the clutch discs are replaced (see page [15-22](#)).

Assembly:

1. Place one special tool in a vise. Place the left side of the differential assembly on the special tool, then preset the differential with 3–5 rotations, both clockwise and counterclockwise.

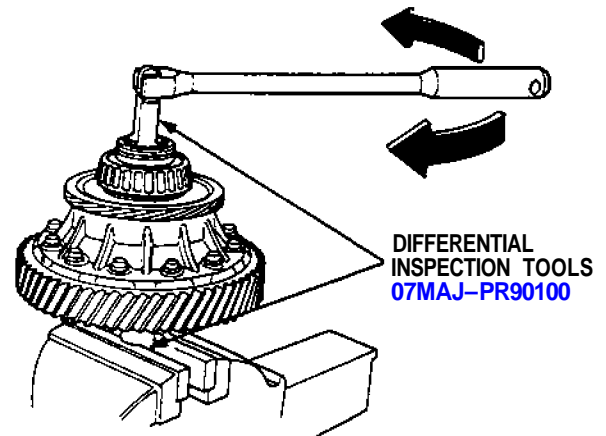

2. Measure preset torque clockwise using a torque wrench as shown.

Standard: 60–140 N·m
(6–14 kg·m, 43–101 lb·ft)
Service Limit: 30 N·m (3 kg·m, 22 lb·ft)

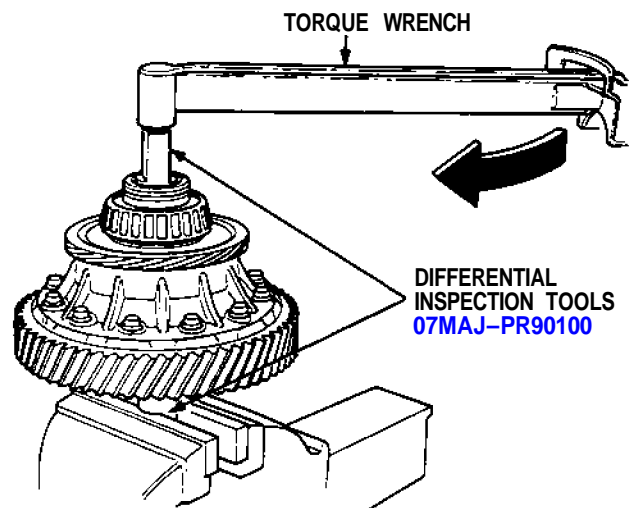

3. If preset torque is less than the service limit, replace the clutch discs with new ones.

NOTE: Adjust the thrust shim whenever the clutch discs are replaced (see page [15-22](#)).