

# Anti-lock Brake System (ABS) Description

## Features/Construction/Operation

### General

In a conventional brake system, if the brake pedal is depressed excessively, the wheels can lock before the vehicle comes to a stop. In such a case, the stability of the vehicle is reduced if the rear wheels are locked, and maneuverability of the vehicle is reduced if the front wheels are locked, creating an extremely unstable condition.

The Anti-lock Brake System (ABS) modulates the pressure of the brake fluid applied to each caliper, thereby preventing the locking of the wheels, whenever the wheels are likely to be locked due to excessive braking. It then restores normal hydraulic pressure when there is no longer any possibility of wheel locking.

### 4-Channel Anti-lock Brake System (ABS) Features

- Increased braking stability can be achieved regardless of changing driving conditions.
- The maneuverability of the vehicle is improved as the system prevents the front wheels from locking.
- When the anti-lock brake system goes into action, kickback is felt on the brake pedal.
- The anti-lock brake system is equipped with a self-diagnosis function. When an abnormality is detected, the ABS indicator light comes on. The location of the abnormality can be diagnosed from the frequency of the system indicator light display blinks.
- This system has individual control of the front and rear wheels. Braking force is controlled on each of the four wheels independently, resulting in optimum braking effects on the four wheels.

The system has a fail-safe function that allows normal braking if there's a problem with the anti-lock brake system.

### Difference Between The 3-Channel And 4-Channel Anti-lock Brake System

Items	3-Channel	4-Channel
Gear Pulser	Front: 50 Rear: 50	Front: 47 Rear: 50
ABS Control Unit	12 and 18 pins	18 and 20 pins
Modulator Solenoid Unit	4 Pistons 3 Solenoid Valves	4 Pistons 4 Solenoid Valves
Service Check Connector	No	Yes
System Control Method	Front wheels controlled independently. Rear wheels controlled commonly	Four wheels controlled independently.
Rear Brakes are provided with Proportioning Control Valve function	Yes	No

### Construction

In addition to the conventional braking system, the anti-lock brake system is composed of: gear pulsers attached to the rotating part of individual wheels; wheel sensors, which generate pulse signals in correspondence to the revolution of the gear pulsers; ABS control unit, which controls the working of the anti-lock brake system by performing calculations based on the signals from the individual wheel sensors and the individual switches; a modulator unit, which adjusts the hydraulic pressure applied to each caliper on the basis of the signals received from the ABS control unit; an accumulator, in which high-pressure brake fluid is stored; a pressure switch, which detects the pressure in the accumulator and transmits signals to the ABS control unit; a power unit, which supplies the high-pressure working fluid to the accumulator by means of a pump; a motor relay for driving the power unit; a fail-safe relay, which cuts off the solenoid valve ground circuit when the fail-safe device is at work; and, an ABS indicator light.

## Master Cylinder

### 1. Construction

A tandem master cylinder with center valves are used to improve braking system safety.

The master cylinder has one reservoir tank which is connected to the cylinder sections by two small holes. It has two pistons - primary and secondary, which are crisscross connected with the calipers so that the fluid pressure works separately on each system (front right wheel & rear left wheel, and front left wheel & rear right wheel).

A stop bolt for controlling movement of the primary piston is provided at the side of the master cylinder body.

A reed switch for detecting the brake fluid volume is also provided on the cap of the reservoir tank.

### 2. Operation

When the brake pedal is depressed, the secondary piston is pushed through the brake booster and center valve B is closed so that the fluid pressure is generated on the secondary side. At the same time, the primary piston is pushed by the secondary fluid pressure and center valve A is closed so that braking fluid pressure is generated both on the primary and secondary sides.

When the brake pedal is released, the primary and secondary pistons are returned to the original positions by the brake fluid pressure and piston spring.

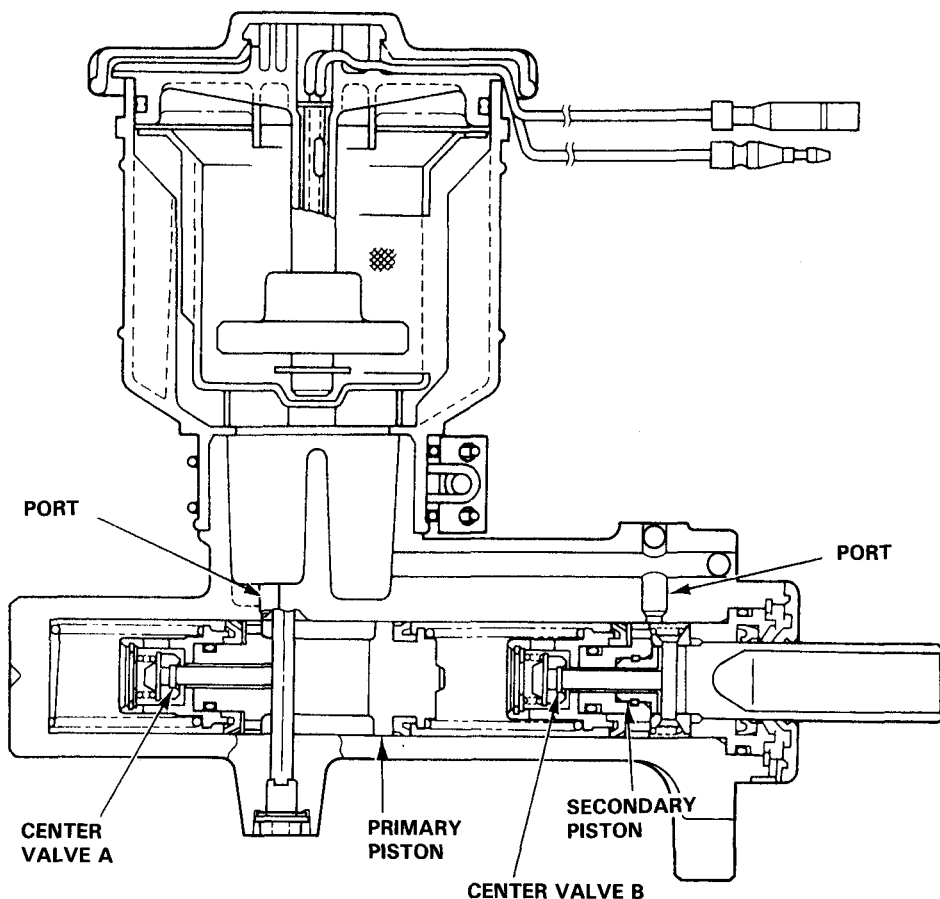

(cont'd)

# Anti-lock Brake System (ABS) Description

## Features/Construction/Operation (cont'd)

### 3. Responses when fluid is leaking

#### (1) In case of leaking from the primary system

Since the fluid pressure on the primary side does not rise, the primary piston is pushed by the fluid pressure of the secondary piston and the tension of the piston spring until the end hits on the cylinder; the braking is performed by the fluid pressure on the secondary side.

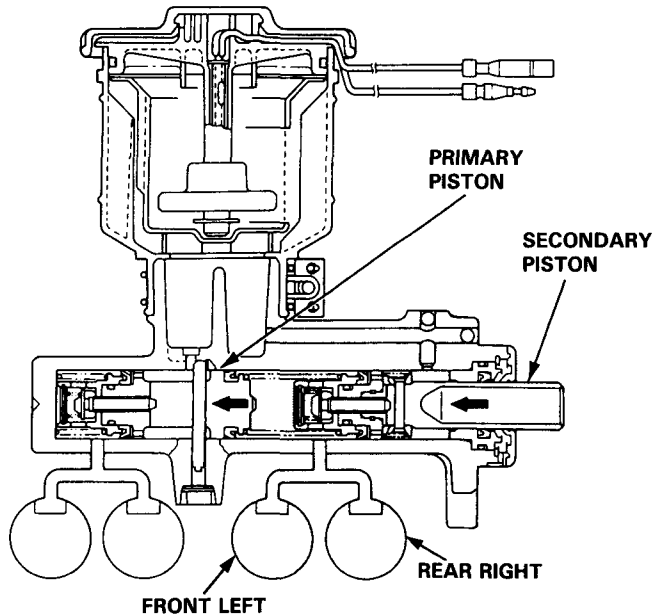

#### (2) In case of leaking from the secondary system

The secondary piston does not produce fluid pressure, keeps moving ahead, hits on the end surface of the primary piston so that the primary piston is pushed under the same condition as an ordinary rod; the braking is performed by the fluid pressure on the primary side.

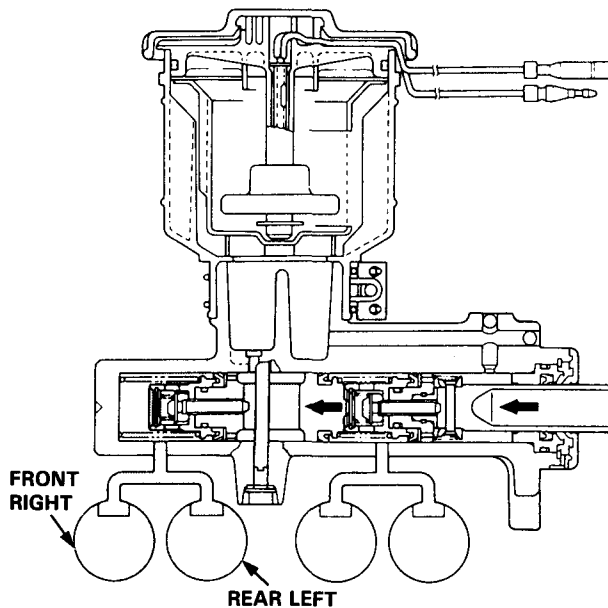

### Wheel Sensor

The wheel sensor is a contactless type, and it detects the rotating speeds of a wheel. It is composed of a permanent magnet and coil. When the gear pulsers attached to the rotating parts of each wheel (rear wheel: outboard joint of the driveshaft, front: hub bearing unit) turn, the magnetic flux around the coil in the wheel sensor alternates, generating voltages with frequency in proportion to wheel rotating speed. These pulses are inputted into the ABS control unit, and the ABS control unit identifies the wheel speeds.

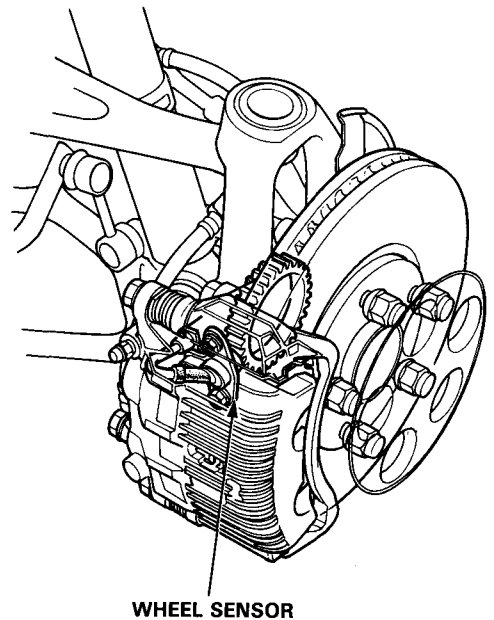
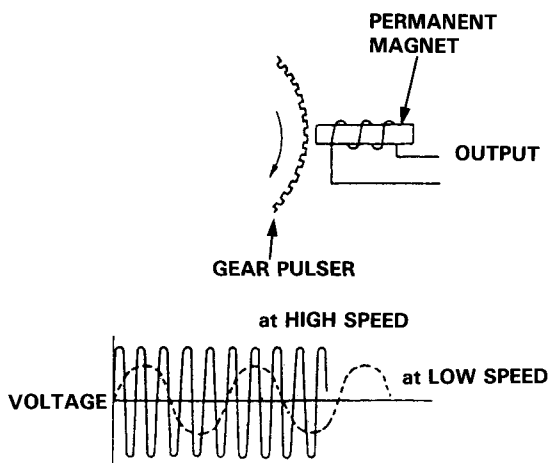

(cont'd)

# Anti-lock Brake System (ABS) Description

## Features/Construction/Operation (cont'd)

### ABS Control Unit

The ABS control unit consists of a main function section, which controls the operation of anti-lock brake system, and sub-function, which controls the pump motor and "self-diagnosis."

#### 1. Main Function

The main function section of the ABS control unit performs calculations on the basis of the signals from each wheel sensor and controls the operation of the anti-lock brake system by putting into action the solenoid valves in the modulator unit for each front and rear brake.

#### 2. Sub-Function

The sub-function section gives driving signals to the pump motor and also gives "self-diagnosis" signals, necessary for backing up the anti-lock brake system.

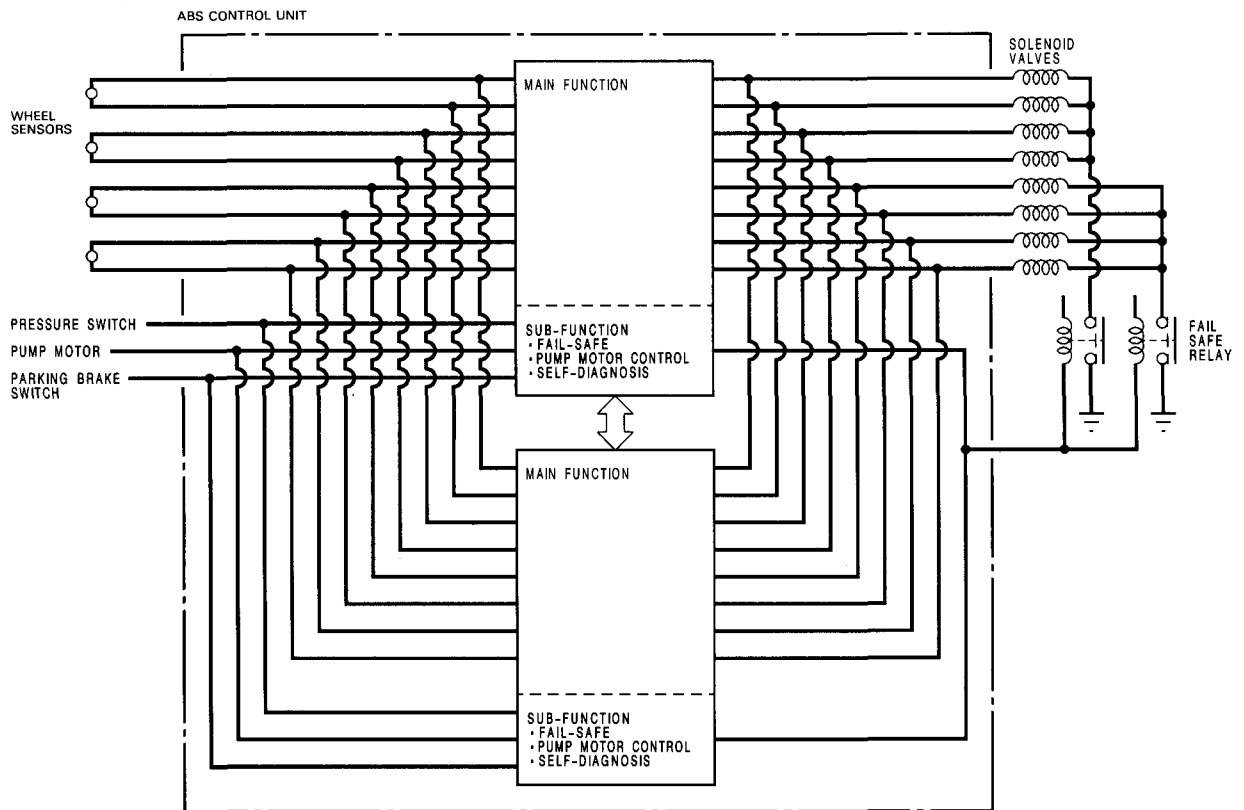

### Self-Diagnostic Function

Since the anti-lock brake system modulates the braking pressure when a wheel is about to lock, regardless of the driver's intention, the system operation and the braking power will be impaired if there is a malfunction in the system. To prevent this possibility, at speeds above 6 mph (10 km/h), the self-diagnosis function monitors the main system functions. When an abnormality is detected, the ABS indicator light comes on.

There is also a check mode of the self-diagnosis system itself: when the ignition switch is first turned on, the ABS indicator light comes on and stays on for a few seconds after the engine starts, to signify that the self-diagnosis system is functional.

### Fail-Safe Function

If an abnormality is detected, the ABS control unit turns off the fail-safe relays and motor relay. In this condition, the anti-lock brake system is prevented from functioning, yet the basic brake system continues to operate normally.

### The ABS Indicator Light Comes On

1. When the fluid pressure pump runs more than 120 seconds.
2. When the parking brake is applied for more than 30 seconds while the vehicle is being driven.
3. When the rear wheel(s) is (are) locked more than a specified time.
4. When the wheel rotation signal is not transmitted due to faulty wire or sensor.
5. When the operation time of the solenoid valve(s) exceeds a predetermined valve, and the ABS control unit finds an open in the solenoid circuit.
6. When the output signals from both main functions in the ABS control unit are not transmitted to the solenoid valve(s).

**Modulator Unit**

Modulators and solenoid valves for each wheel are integrated in the modulator unit. The modulators for front and rear brakes are of independent construction. The solenoid valve features quick response (5 ms or less). The inlet and outlet valves are integrated in the solenoid valve unit.

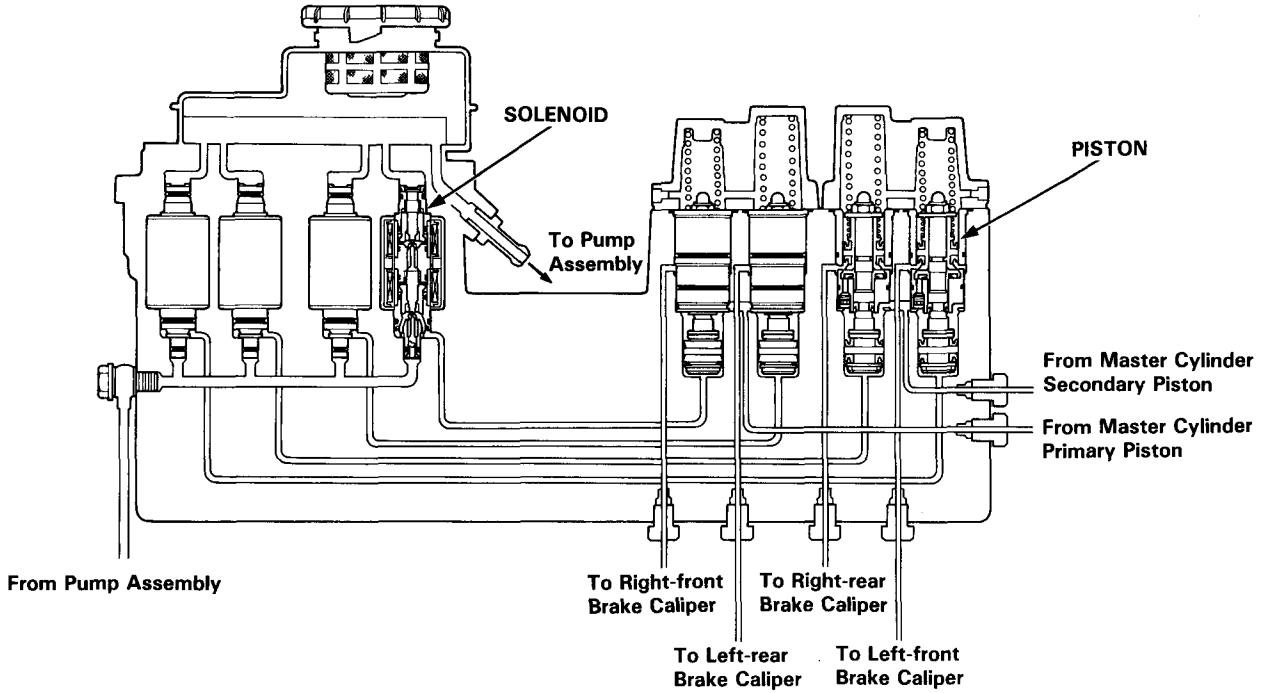

**Accumulator**

The accumulator is a pneumatic type which accumulates high-pressure brake fluid fed from the pump incorporated in the power unit. When the anti-lock brake system operates, the accumulator feeds high-pressure brake fluid to the modulator valve via the inlet side of the solenoid valve.

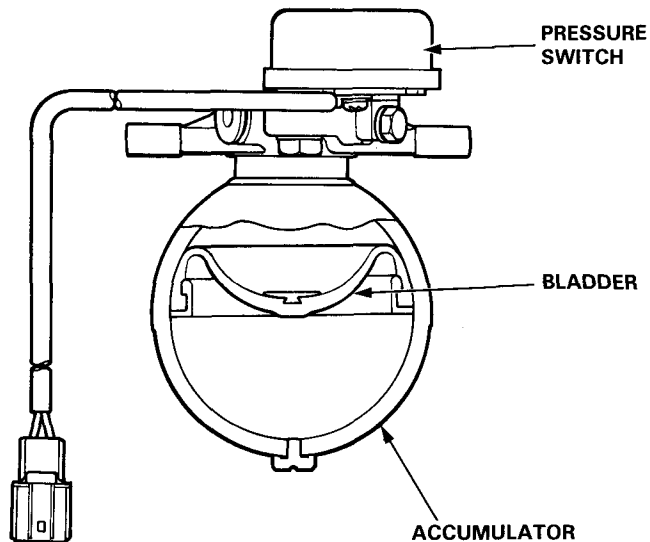

(cont'd)

# Anti-lock Brake System (ABS) Description

## Features/Construction/Operation (cont'd)

### Pressure Switch

The pressure switch monitors the pressure accumulation (pressure from the pump) in the accumulator and is turned off when the pressure becomes lower than a prescribed level. When the pressure switch is turned off, the switching signal is sent to the ABS control unit. Upon receiving the signal, the ABS control unit activates the pump motor relay to operate the motor. If the pressure doesn't reach the prescribed value, the ABS indicator light is turned on.

### Operation

When the pressure in the accumulator rises, the Bourdon tube in the pressure switch deforms outwards. When the free end of the Bourdon tube moves more than the prescribed amount, the micro-switch is activated by the force of the spring attached to the sensing lever. When the pressure in the accumulator decreases due to anti-lock brake system operations, the Bourdon tube moves in the direction opposite to the one described above, and the micro-switch is eventually turned off. Upon receiving this signal, the ABS control unit activates the motor relay to operate the motor.

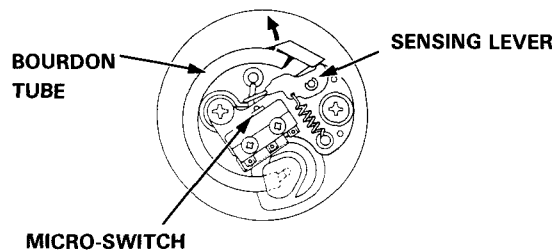

### Power Unit

The power unit consists of a motor and a plunger-type pump. This unit transmits the revolution of the motor to the plunger by way of an eccentric bearing and supplies high-pressure brake fluid to the accumulator by the effect of the reciprocating movement of the plunger.

When the pressure in the accumulator drops below the prescribed pressure level, the pressure switch gives an OFF-signal. The ABS control unit turns the motor relay ON to start the operation of the pump, upon the reception of this signal and a signal from the wheel sensor that the vehicle is running at a speed greater than 6 mph (10 km/h). When the pressure in the accumulator attains the prescribed pressure, the ABS control unit turns the motor relay OFF approximately three seconds after the unit receives an ON-signal from the pressure switch. By this, the high-pressure in the accumulator is maintained.

The ABS control unit turns the pump off and lights the system indicator light if the accumulator pressure does not reach the prescribed level after the pump has run continuously for 120 seconds.

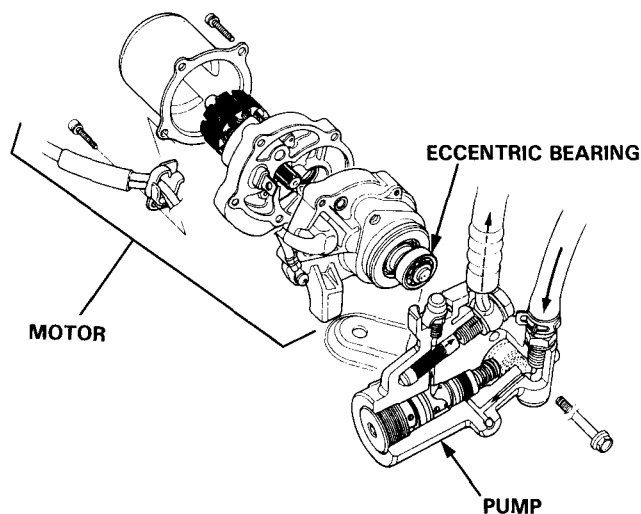

**Operation**

1. Ordinary Braking Function

In ordinary brake operations, the cut-off out valve in the modulator is open to transmit the hydraulic pressure from the master cylinder to the brake calipers via the chamber A and the chamber B.

The chamber C is connected to the reservoir through the outlet valve which is normally open. It is also connected to the hydraulic pressure source (pump, accumulator, pressure switch, etc.) via the inlet valve which is normally closed. The chamber D serves as an air chamber. Under these conditions, the pressures of the chambers C and D are maintained at about the atmospheric pressure, permitting regular braking operations.

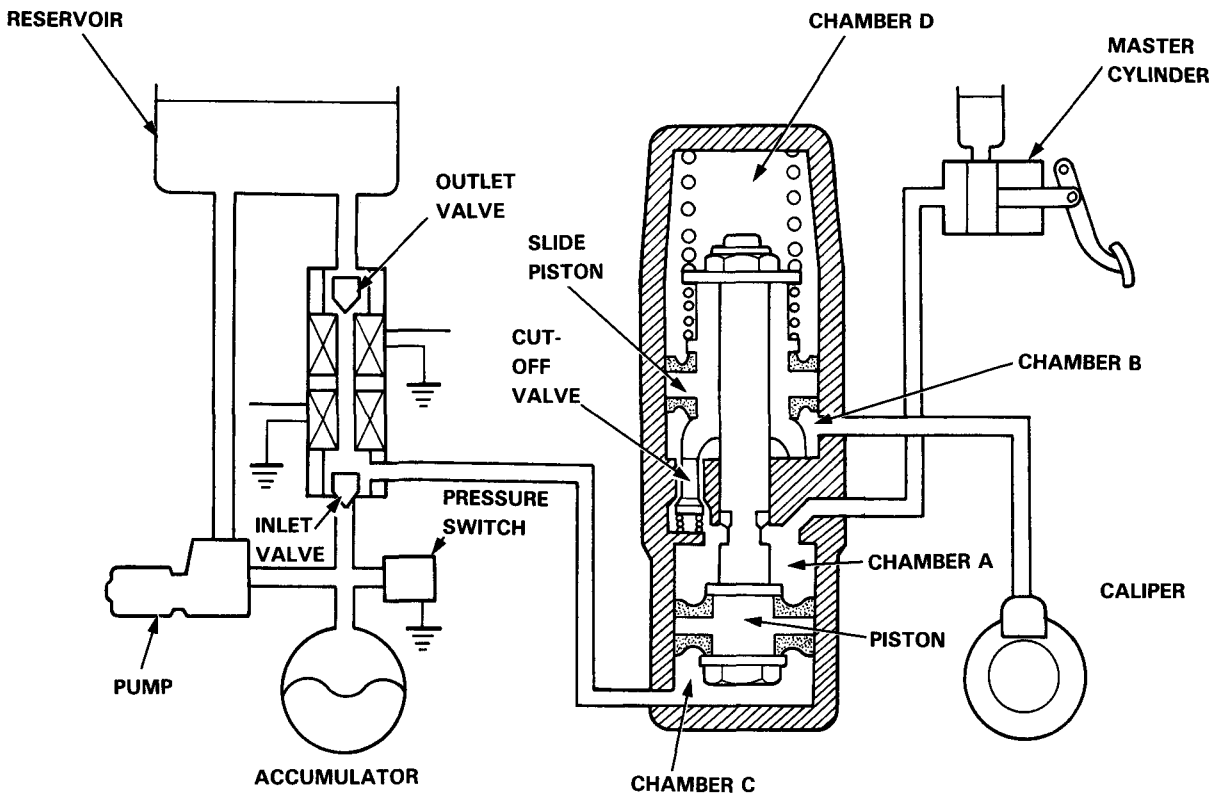

(cont'd)



# Anti-lock Brake System (ABS) Description

## Features/Construction/Operation (cont'd)

If brake inputs (force exerted on brake pedal) are excessively large and a possibility of wheel locking occurs, the control unit operates the solenoid valve, closing the outlet valve and opening the inlet valve. As a result, the high pressure is directed into chamber C, the piston is pushed upward, causing the slide piston to move upward and the cut-off valve to close.

As the cut-off valve closes, the flow from the master cylinder to the caliper is interrupted, the volume of chamber B, which is connected to the caliper, increases, and the fluid pressure in the caliper declines.

When both of the two valves, inlet and outlet, are closed (when only the outlet valve is activated) the pressure in the caliper is maintained constant.

When the possibility of wheel locking ceases, it is necessary to restore the pressure in the caliper. The solenoid valve is therefore turned off (outlet valve: open, inlet valve closed).

Process	Caliper Pressure	Outlet Valve		Inlet Valve	
		Electric Power	Hydraulic Circuit	Electric Power	Hydraulic Circuit
Caliper pressure declining	Down	ON	Close	ON	Open
Caliper pressure constant	Hold	ON	Close	OFF	Close
Caliper pressure increasing	Up	OFF	Open	OFF	Close

### Slide Piston Function

When the car is used on rough roads where the tires sometimes lose adhesion, the anti-lock brake system may function excessively, causing an excessively large volume of brake fluid to flow into the chamber C. As this occurs, the piston is moved excessively, resulting in an abnormal loss of pressure in the chamber B. In order to overcome this problem, the slide piston is kept in the proper position by the spring force to avoid a negative pressure in the chamber B.

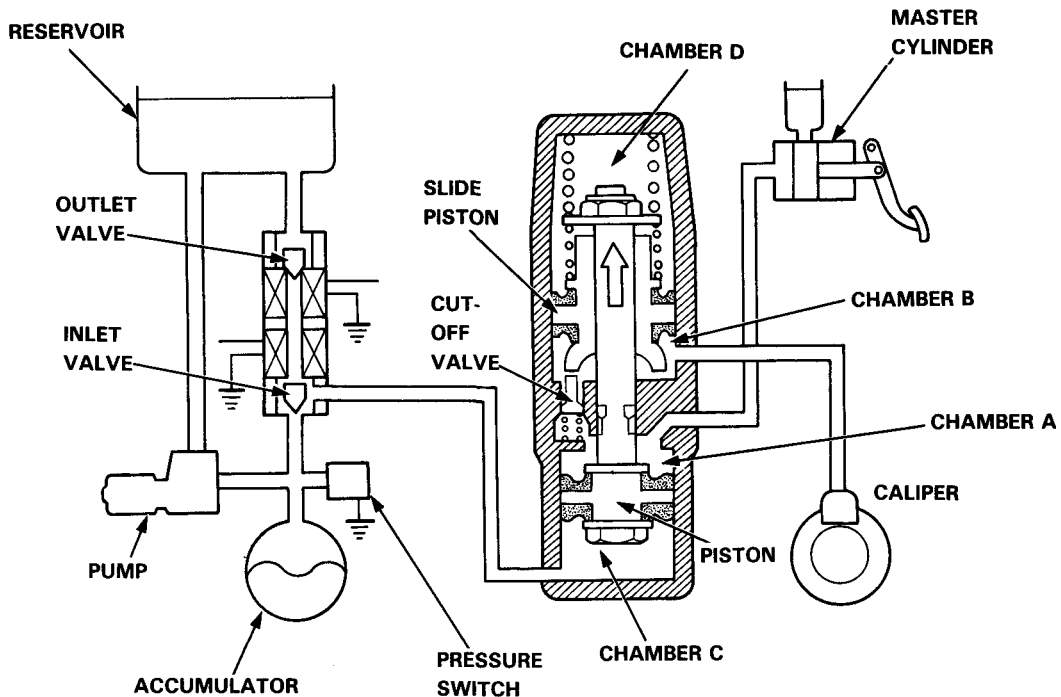

### Kickback

When anti-lock brake system is functioning, the piston moves upward, the volume of chamber B increases, and the fluid pressure on the caliper side is reduced. At the same time, the volume of chamber A is reduced and the brake fluid is returned to the master cylinder. When the brake fluid is pushed back to the master cylinder, the driver can feel the functioning of the anti-lock brake system because the brake pedal is kicked back.