



# Disassembly

NOTE: Lower the glass fully.

1. Carefully pry out the trim plate with a flat tip screwdriver as shown.

**CAUTION:** To prevent damage to the trim plate, wrap the end of the screwdriver with a shop towel.

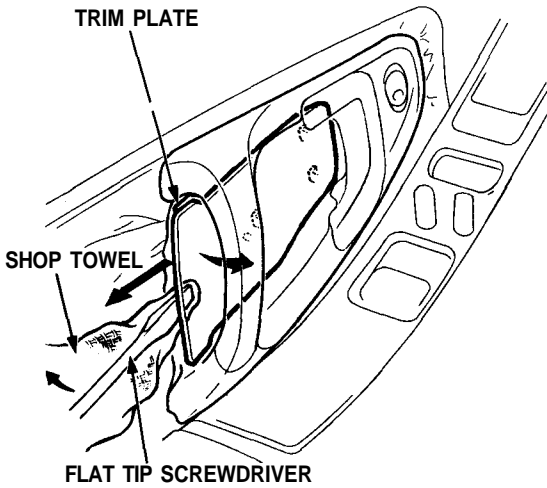

2. Remove the trim plate by pulling it backward, and remove the mounting screws.

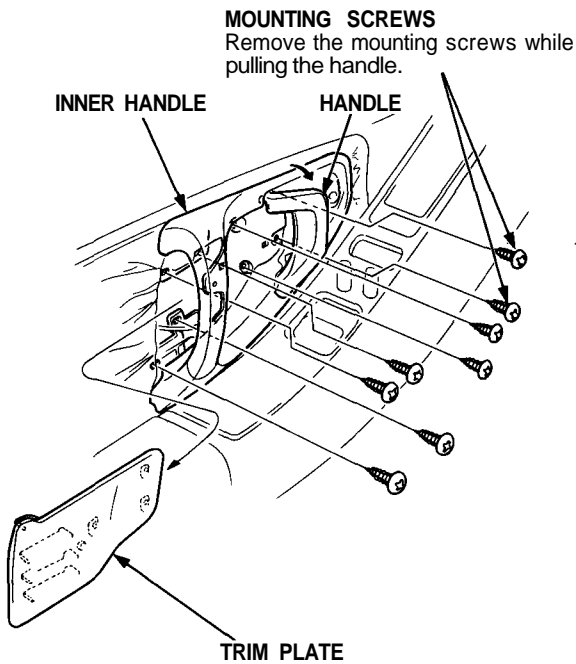

3. Disconnect the connector and handle cable, then remove the inner handle by pulling it forward.

NOTE: Take care not to bend the handle cable.

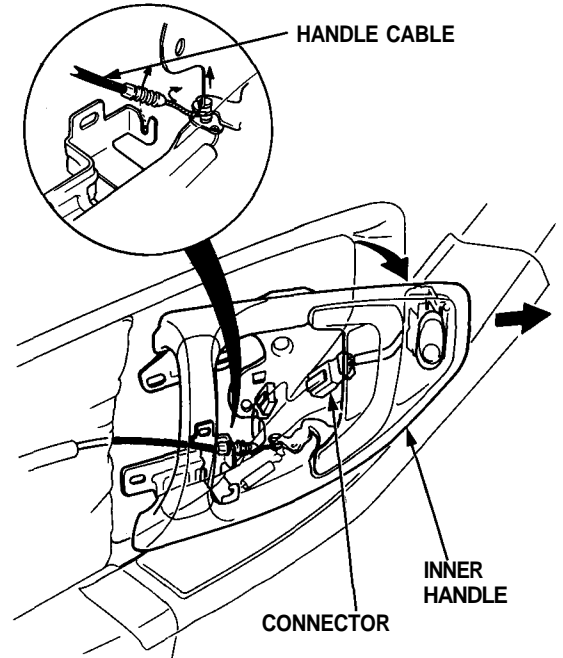

4. Carefully remove the front and rear sash covers.

NOTE: Take care not to scratch the sash covers.

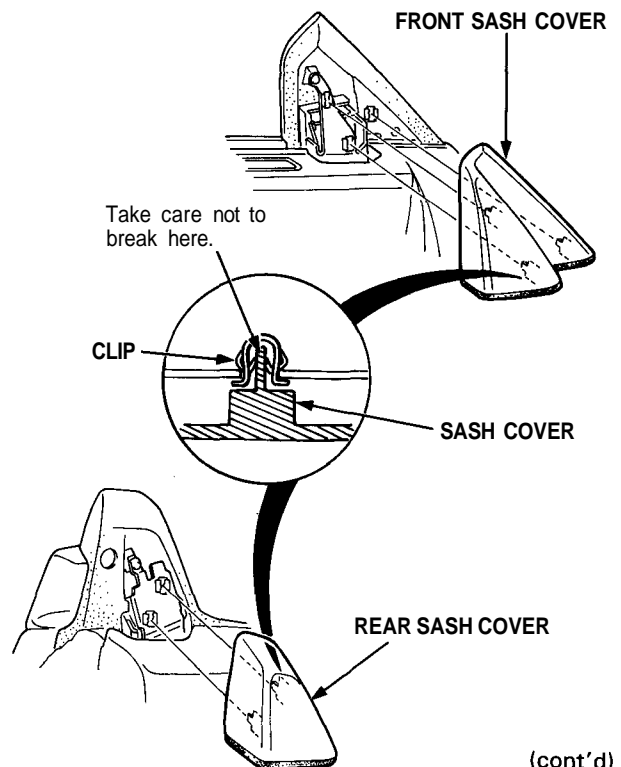

(cont'd)

# Doors

## Disassembly (cont'd)

5. Remove the mounting screws. Lift the door panel straight up off the sill.

Disconnect the connectors:

- Trunk lid opener
- Power window/Door mirror
- Courtesy light
- Security alarm

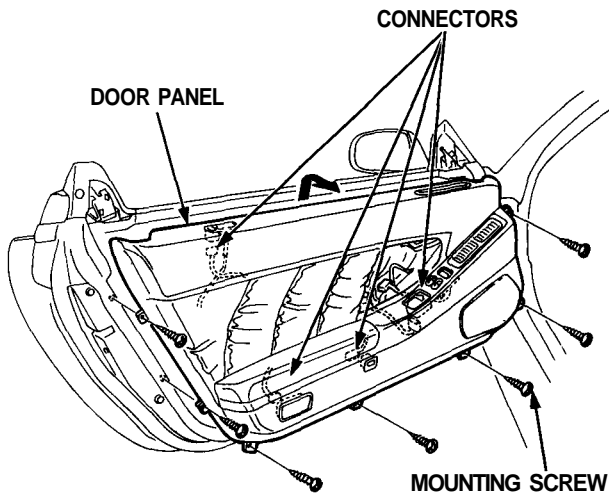

6. Remove the switch panel and air duct from the door panel as required.

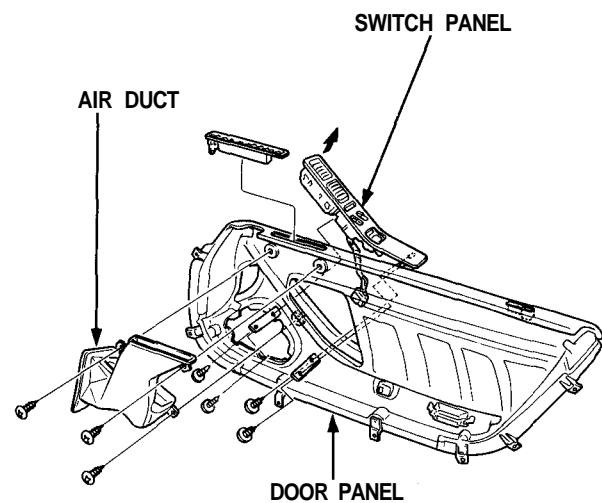

7. Remove the mounting screws and disconnect the connectors, then remove the power window control unit and speaker unit.

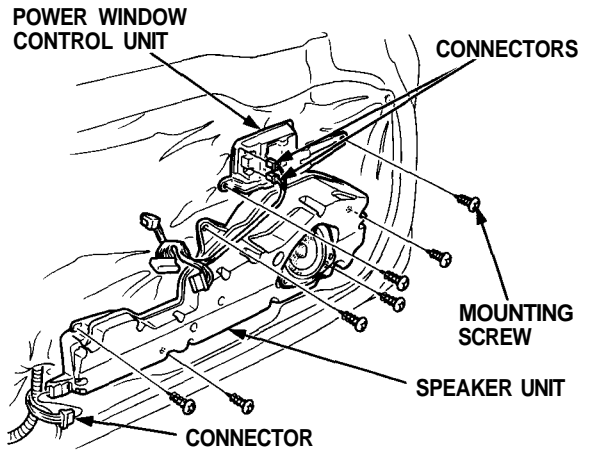

8. Remove the lower door weatherstrip retaining clips, then pull off the lower door weatherstrip. Remove the screw grommets, and carefully remove the plastic cover.

▶: Clip locations

○: Clip locations

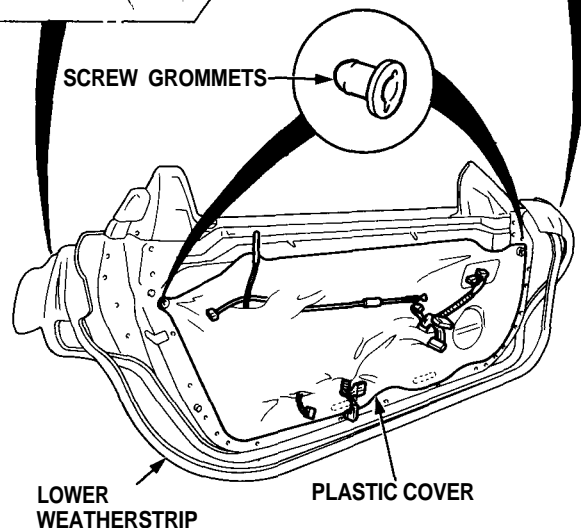
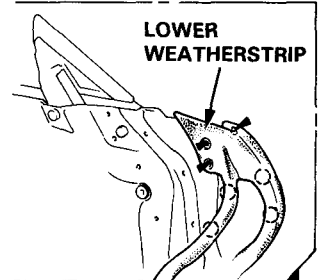
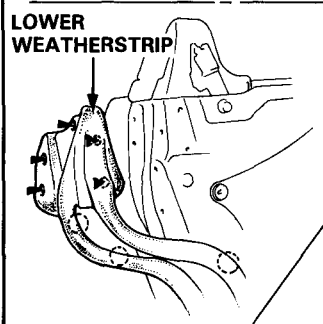



9. Remove the mounting screws, then remove the front sash panel from the front sash.

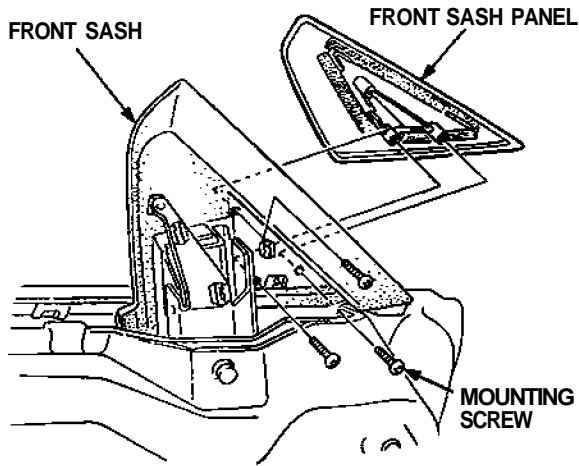

10. Remove the outer molding (see page 20-12 ('93-'96),11('91-'92))

11. Remove the mounting bolts and locknut, then remove the front sash.

**NOTE:**

- Hold the adjusting bolt with a hex wrench when removing the locknut.
- Scribe a line around the locknut to show the original adjustment.

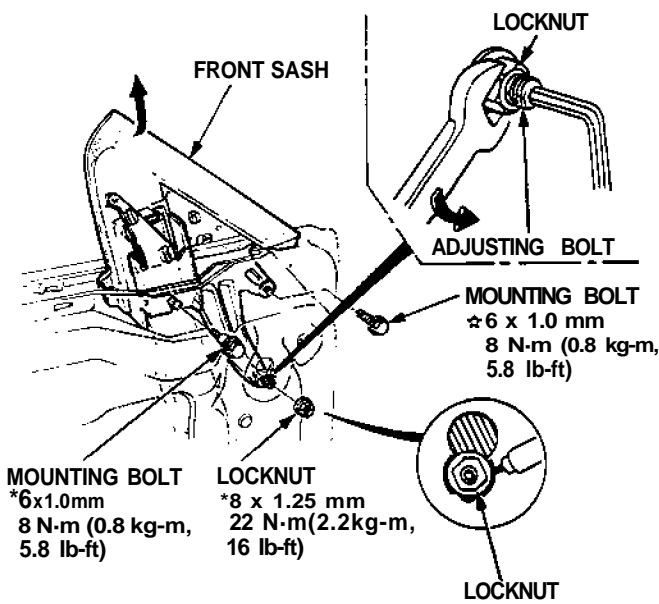

☆: CORROSION RESISTANT BOLT/NUT

12. Remove the mounting bolt, locknut and adjusting bolt. Remove the rear sash, then disconnect the handle rod.

**NOTE:**

- Before removing the adjusting bolt, measure and record the clearance (A) between the rear sash and door.
- Scribe a line around the locknut to show the original adjustment.
- Take care not to bend the handle rod.

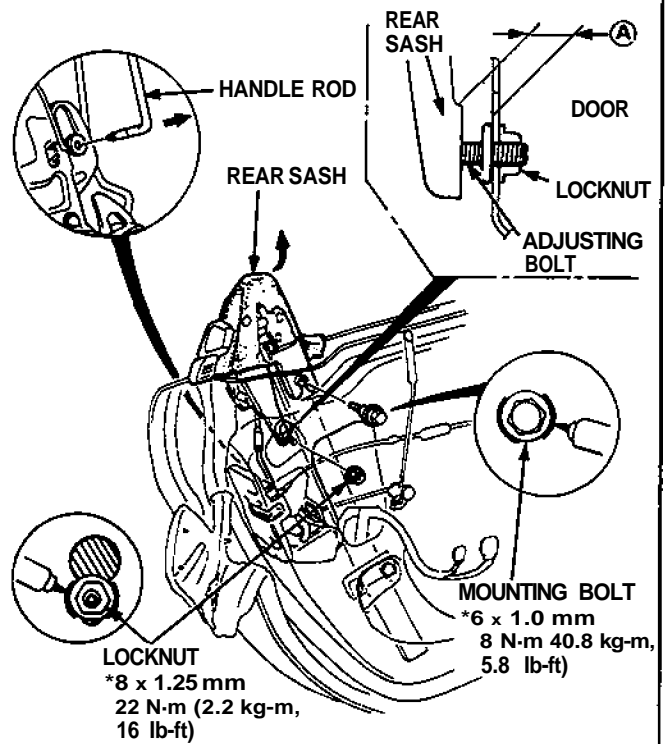

\*: CORROSION RESISTANT BOLT/NUT

13. To replace the outer handle, remove the mounting screws from the rear sash.

**NOTE:** Apply grease to the moving surfaces.

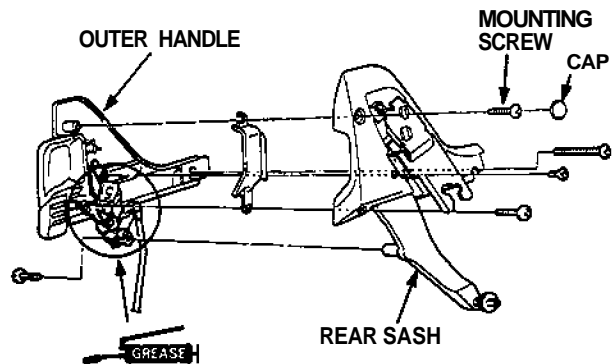

(cont'd)

# Doors

## Disassembly (cont'd)

14. Remove the locknuts, then remove the rear glass guide.

**NOTE:**

- Hold the adjusting bolt with a hex wrench when removing the locknuts.
- Scribe a line around the locknuts to show the original adjustment.

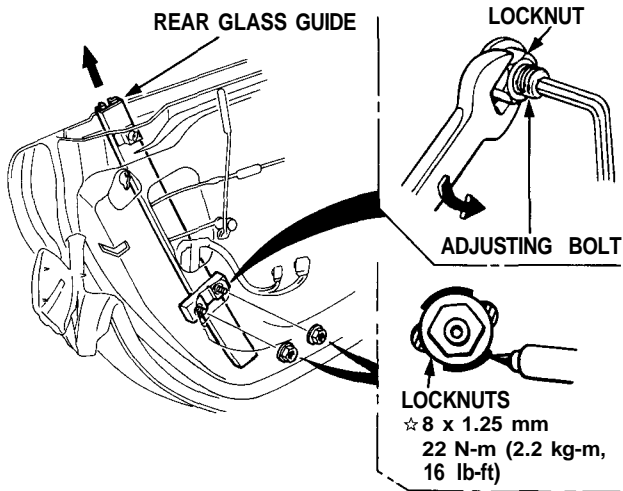

☆: CORROSION RESISTANT BOLT/NUT

15. Before removing the latch assembly and lock cylinder, raise the glass fully by connecting a 12 V battery to the power window motor (see [section 23](#)).

16. Remove the retainer by sliding it forward. Pry the cylinder rod out its joint using a flat tip screwdriver, then carefully remove the lock cylinder.

**NOTE:** Take care not to bend the cylinder rod.

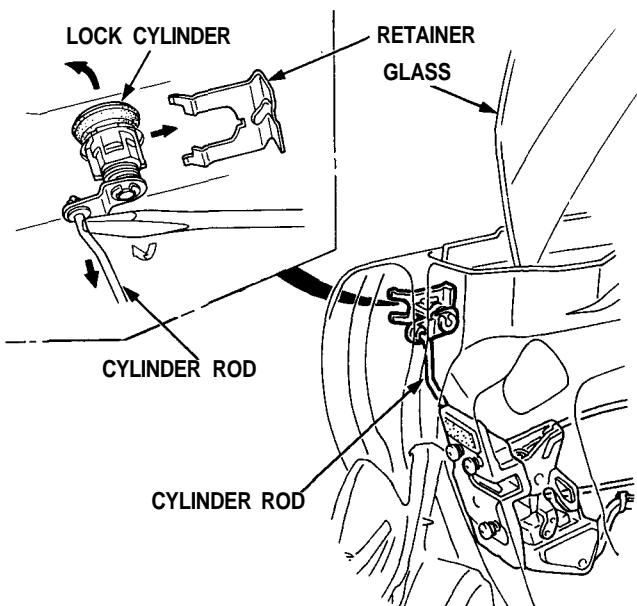

17. Disconnect the lock rod and remove the lock crank. Remove the handle cable and clips. Remove the mounting screws, then remove the latch assembly through the hole in the door.

**NOTE:** Take care not to bend the lock rod and handle cable.

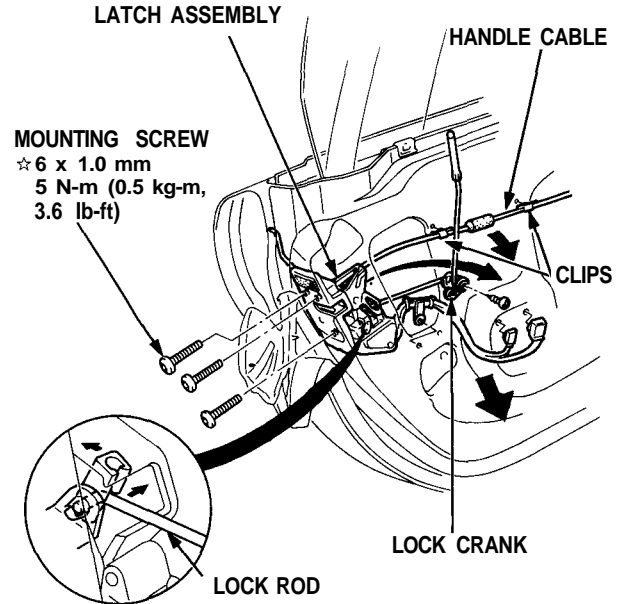

18. Lower the glass and remove the mounting nuts, then remove the stopper plates.

**NOTE:**

- Lower the glass by connecting a 12 V battery to the power window motor (see [section 23](#)).
- Scribe a line around the mounting nuts to show the original adjustment.

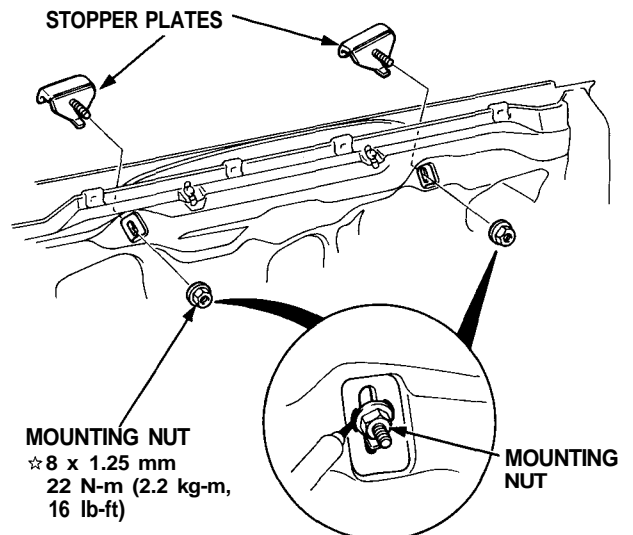



19. Carefully lower the glass until you can see its mounting bolts, then remove them. Pull the glass out through the window slot.

**NOTE:**

- Lower the glass by connecting a 12 V battery to the power window motor (see [section 23](#)).
- Scribe a line around the mounting bolts to show the original adjustment.

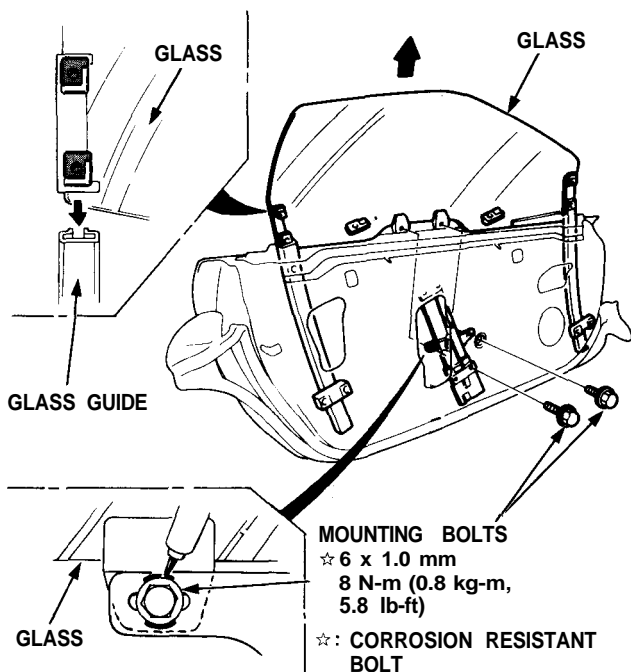

20. Remove the locknuts, then remove the front glass guide.

**NOTE:**

- Hold the adjusting bolt with a hex wrench when removing the locknuts.
- Scribe a line around the locknuts to show the original adjustment.

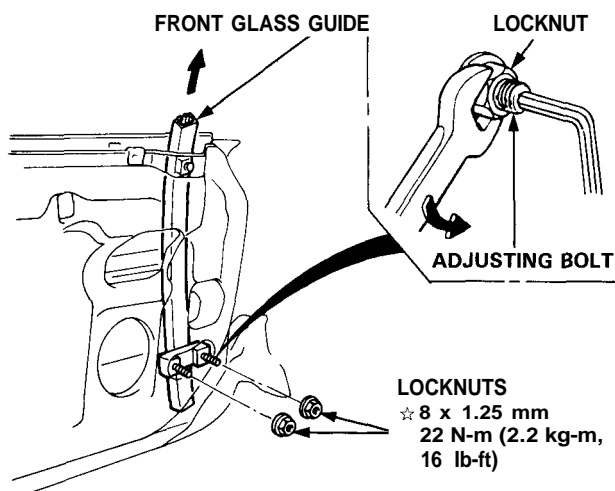

21. Remove the mounting bolts and loosen the motor mounting bolts, then take out the regulator assembly through the window slot.

**NOTE:**

- Scribe a line around the mounting bolts to show the original adjustment.
- Take care not to bend the cables.

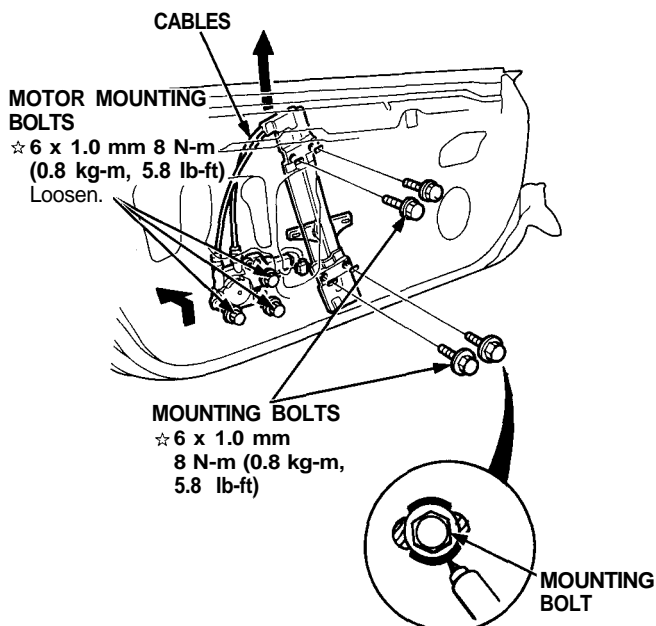

☆: CORROSION RESISTANT BOLT

22. Remove the mounting bolts, then remove the inside stabilizers from the door.

**NOTE:** Scribe a line around the mounting bolts to show the original adjustment.

