



Position Adjustment

After installing the door, check for a flush fit with the body, then check for equal gap between the front, rear, and bottom door edges and the body.

The door and body edges should also be parallel. Adjust at the door hinges as shown.

CAUTION: Place a shop towel or rubber pad on the jack to prevent damage to the door when the hinge bolts are loosened for adjustment.

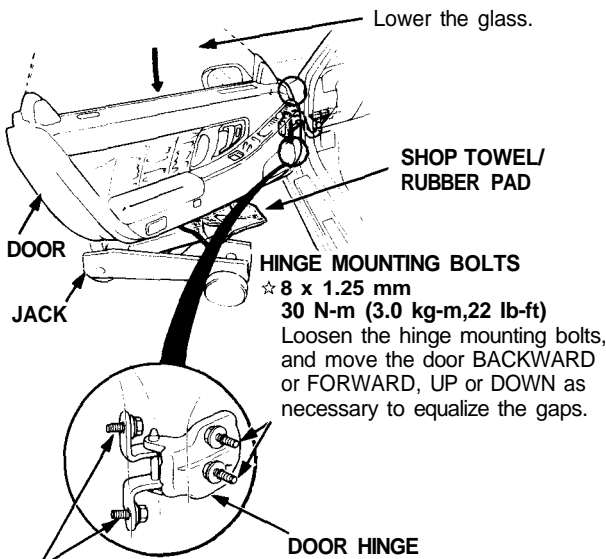

DOOR MOUNTING BOLTS
 ☆ 8 x 1.25 mm
 30 N-m (3.0 kg-m, 22 lb-ft)

Loosen the door mounting bolts slightly to move the door IN or OUT until flush with the body. If necessary, you can install a shim behind one hinge to make the door edges PARALLEL with the body.

☆: CORROSION RESISTANT BOLT

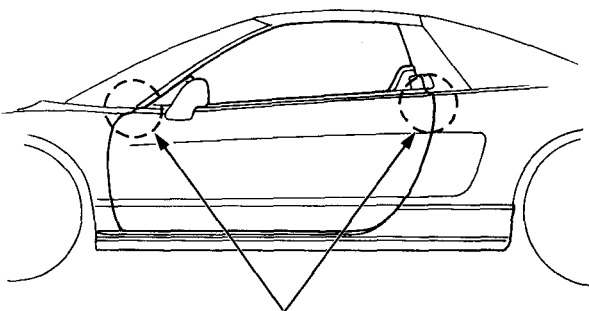

The door and body edges should be parallel.

NOTE: Check for water leaks.

Striker Adjustment

Make sure the door latches securely without slamming. If it needs adjustment:

1. Draw a line around the striker for reference.
2. Loosen the mounting screws, and move the striker IN or OUT to make the latch assembly fit tighter or looser. Move the striker UP or DOWN to align it with the latch assembly opening. Then lightly tighten the mounting screws and recheck.

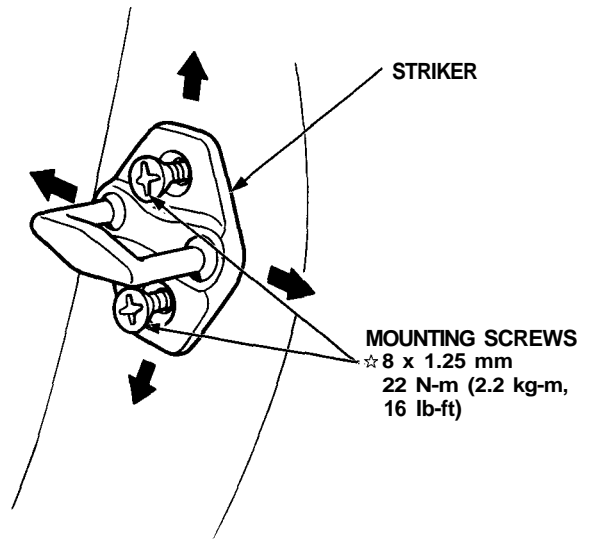

NOTE:

- Hold the outside handle out, and push the door against the body to be sure the striker allows a flush fit.
- Do not tap the striker with a metal hammer to adjust the position.

3. If the door latches properly, tighten the mounting screws and recheck.

NOTE: Replace the striker if it is cracked.

☆: CORROSION RESISTANT SCREW