



Rear Window

Removal

15. Let the adhesive dry for at least one hour, then spray water over the windshield and check for leaks. Mark leaking areas and let the windshield dry, then seal with urethane windshield adhesive.

NOTE:

- Let the car stand for at least four hours after windshield installation. If the car has to be used within the first four hours, it must be driven slowly.
 - Keep the windshield dry within the first hour after installation.
 - Check that the ends of the front pillar retainer are set under the air scoop.
16. Reassemble all removed parts.

CAUTION:

- Wear gloves to remove and install the rear window.
 - Since the rear window is double glazed glass with the inner glass (interior-side) larger than the outer glass, care should be taken not to damage the edge of the inner glass when removing the outer glass.
1. To remove the rear window, first remove:
 - Seats (see page 20-39('93-'96),('91-'92)
 - Center pillar trim panel (see page 20-38) ('93-'96),37('91-'92)
 - Rear upper trim panel (see page 20-38) ('93-'96),37('91-'92)
 - Rear hatch assembly (see page 20-64('93-'96),53('91-'92)
 2. Remove the weatherstrip.
 3. Disconnect the rear defogger sub-harness and ground cable/antenna lead, then remove the grommets.

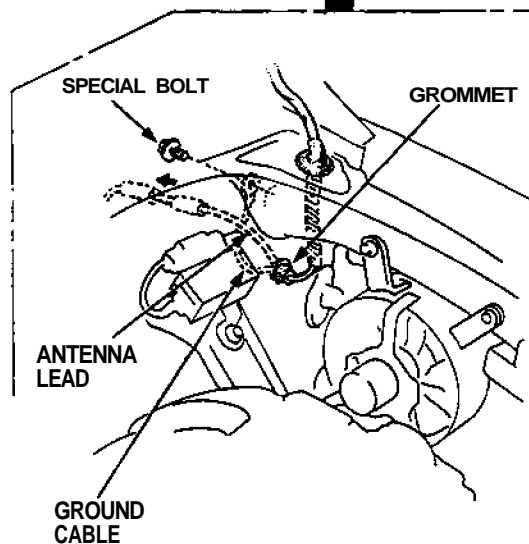
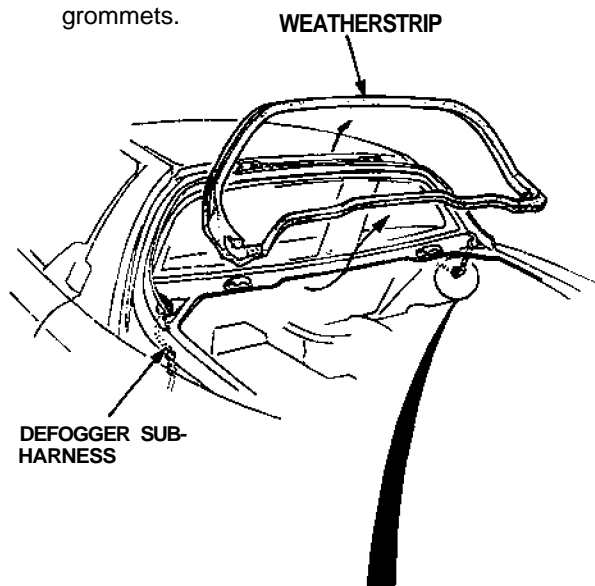

(cont'd)

Rear Window

Removal (cont'd)

4. Remove the rear defogger sub-harness and ground cable/antenna lead from the upper molding.

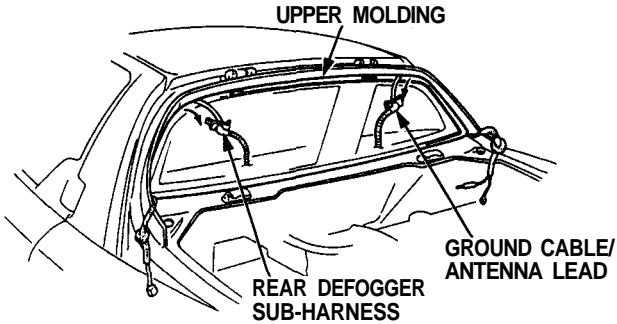

5. Use a knife to cut the upper and lower moldings from outside the car, all the way around.

CAUTION: Take care not to scratch or score the rear window and body.

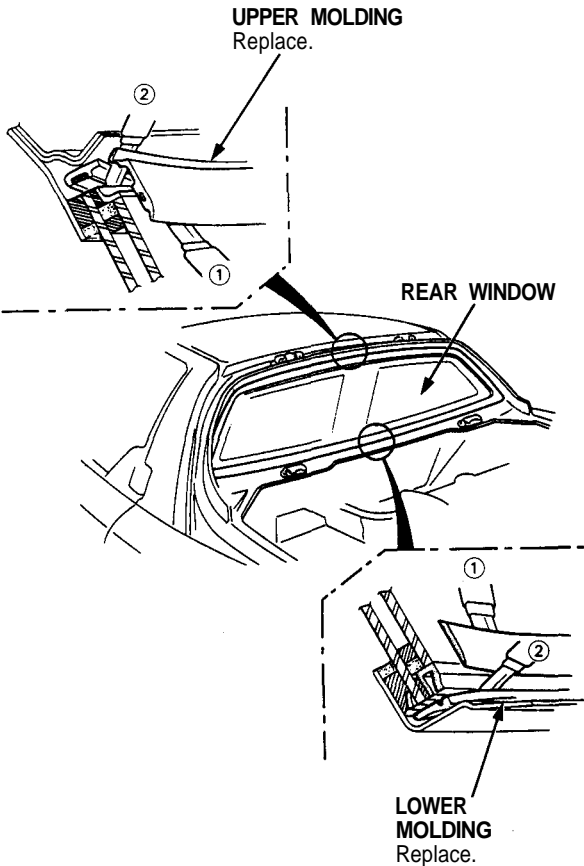

NOTE: Cut the outer side rubber portion ① off the molding, then cut the top rubber portion ②.

6. Apply protective tape along the edge of the body.
7. Using an awl, make a hole through the adhesive from inside the car. Push piano wire through the hole, and wrap each end around a piece of wood.
8. Pull the piano wire back and forth in a sawing motion, and carefully cut through the adhesive around the entire rear window.

CAUTION: Hold the piano wire as close to the rear window as possible to prevent damage to the body.

