

Seats



Replacement

NOTE:

- Before removing the seat, move the seat until you can see its mounting bolts and seat mount cover caps.
- Take care not to scratch the seat cover, interior trim, dashboard and center armrest.
- On reassembly, replace the lower anchor bolt (*) and use liquid thread lock.

1. Pry out the seat mount cover caps.
2. Remove the seat mounting bolts, then remove the seat and disconnect the connector.
3. Pry out the cap, and remove the seat belt lower anchor bolt. Remove the seat.

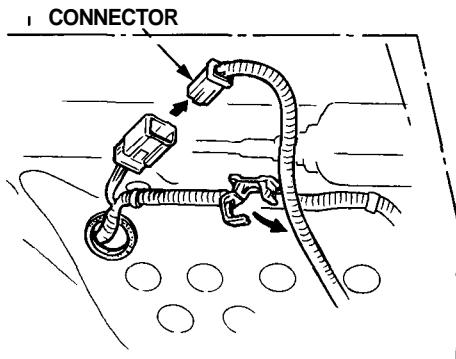
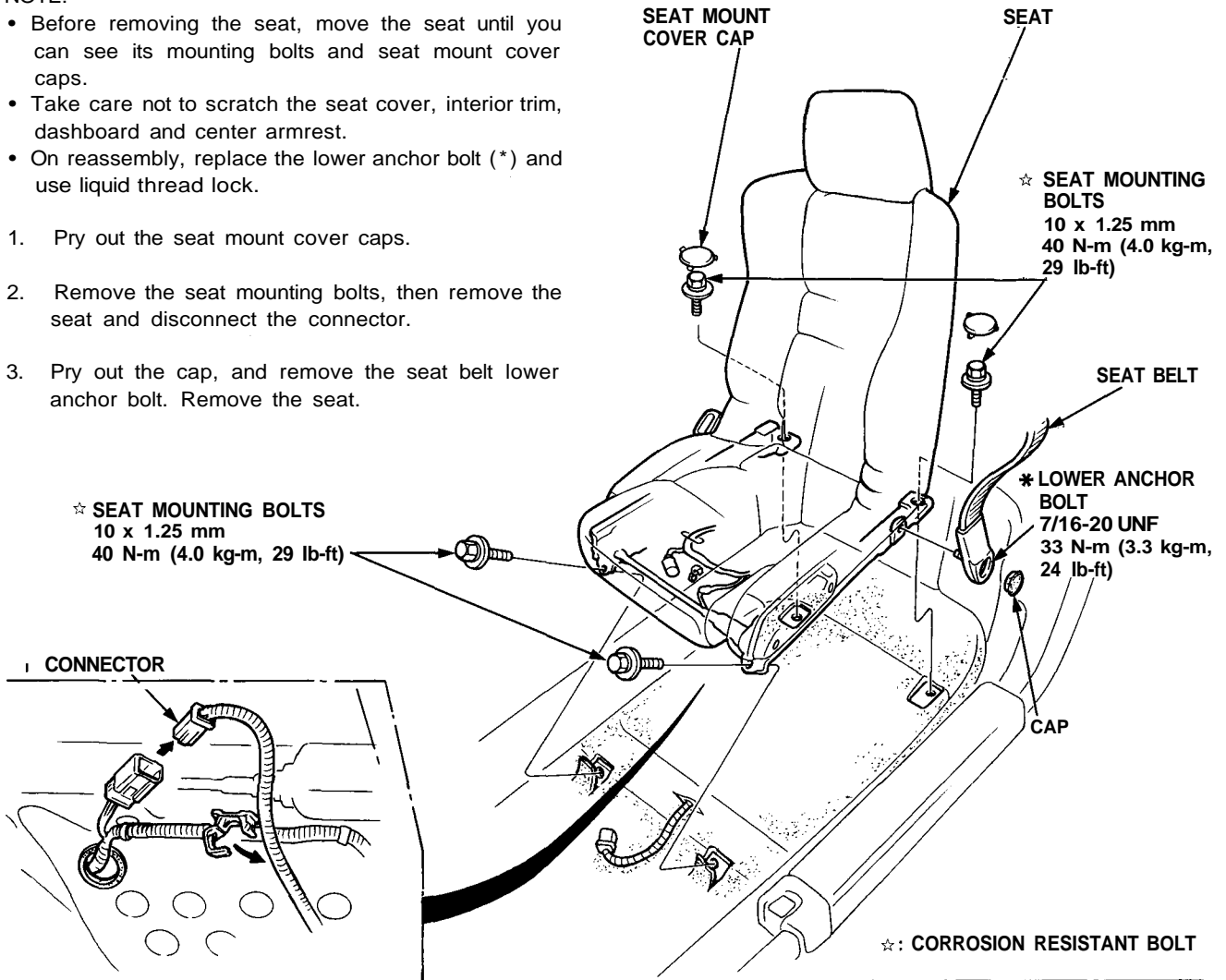

If necessary, remove the power slide cable, power seat switch and seat mount cover.

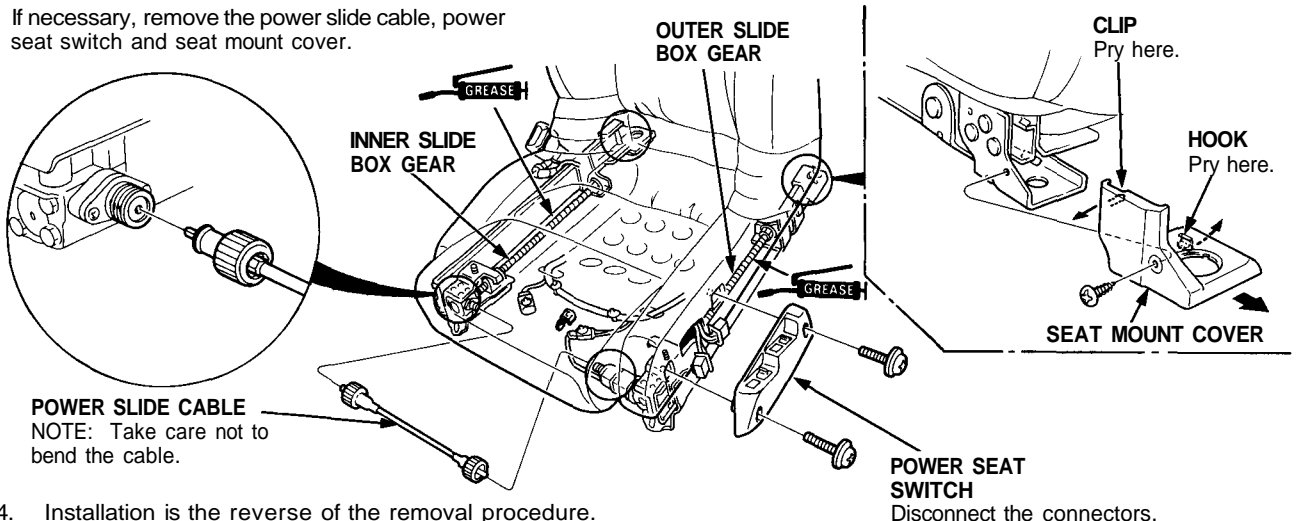

4. Installation is the reverse of the removal procedure.

NOTE: Apply grease to the inner and outer slide box gears.