

# Under-dash Fuse Box

## Removal/Installation

SRS components are located in this area. Review the SRS component locations, precautions, and procedures in the SRS [section 24](#) before performing repairs or service.

### Removal:

1. Disconnect both the negative cable and positive cable from the battery.
2. Carefully remove the side sill pad (pull it up, rear end first).
3. Remove the fuse box door.

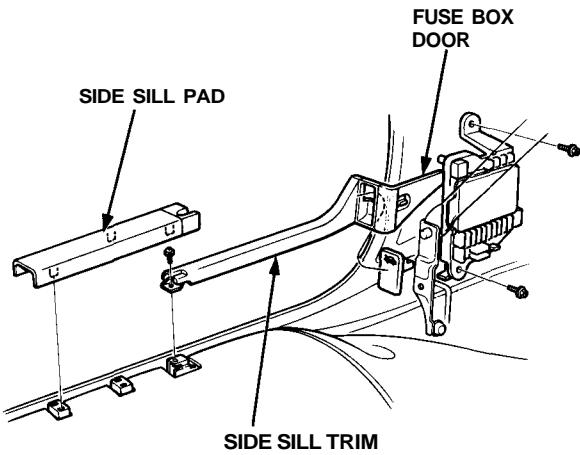

4. Remove the three screws, then remove the side sill trim.
5. Remove the under-dash fuse box mounting bolts.

6. Disconnect the under-dash fuse box connectors.

NOTE: The SRS main harness connector is double locked. To remove it, first lift the connector lid, then press the connector tab down and pull the connector out.

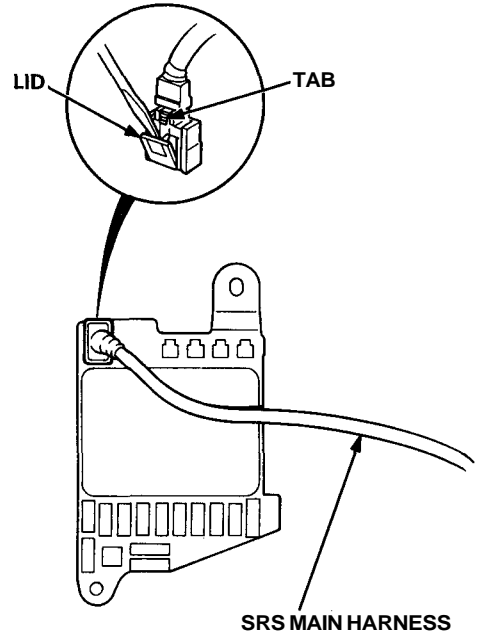

7. Take out the under-dash fuse box.



**Installation:**

1. Connect the connectors to the under-dash fuse box.

NOTE: To reinstall the SRS main harness connector, push it into position until it clicks, then close the connector lid.

2. Install the under-dash fuse box.
3. Install the side sill trim, fuse box door and door sill pad.

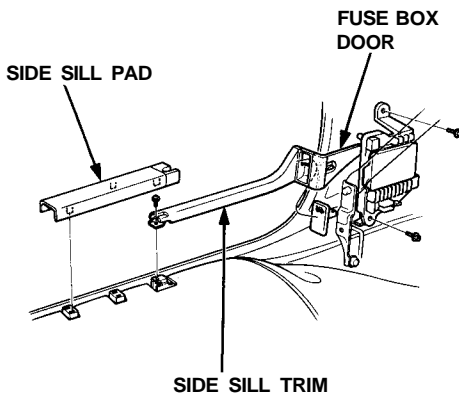

4. Connect both the negative cable and positive cable to the battery.
5. Confirm that all systems work properly.