



## Installation

**CAUTION: Do not rotate the crankshaft or camshaft without installing the belt. The piston could hit a valve and damage may result.**

1. Install the timing belt in the reverse order of removal; Only keypoints are described here.
2. Remove all spark plugs.
3. Position the crankshaft and the camshaft pulley as shown before installing the timing belt.

- A Set the crankshaft so that the No. 1 piston is at top dead center (TDC).  
NOTE: Turn the crankshaft until its keyway is facing up.
- B Align the TDC mark on the front exhaust camshaft pulley and front intake camshaft pulley to the pointer on the front timing belt cover plate.
- C Align the TDC mark on the rear intake camshaft pulley to the pointer on the rear timing belt cover plate.
- D Align the rear exhaust camshaft pulley one half tooth clockwise past TDC.

4. Install the timing belt in the sequence shown.  
① Timing belt drive pulley (crankshaft) → ② Adjusting pulley → ③ Front exhaust camshaft pulley → ④ Front intake camshaft pulley → ⑤ Water pump pulley → ⑥ Rear intake camshaft pulley → ⑦ Rear exhaust camshaft pulley.

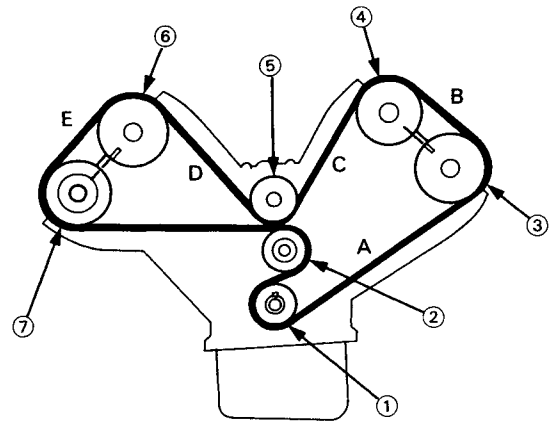

5. Tension the timing belt between the pulleys in the sequence A to E as shown above.
  - Refer to page 6-22 for timing belt tension adjustment.

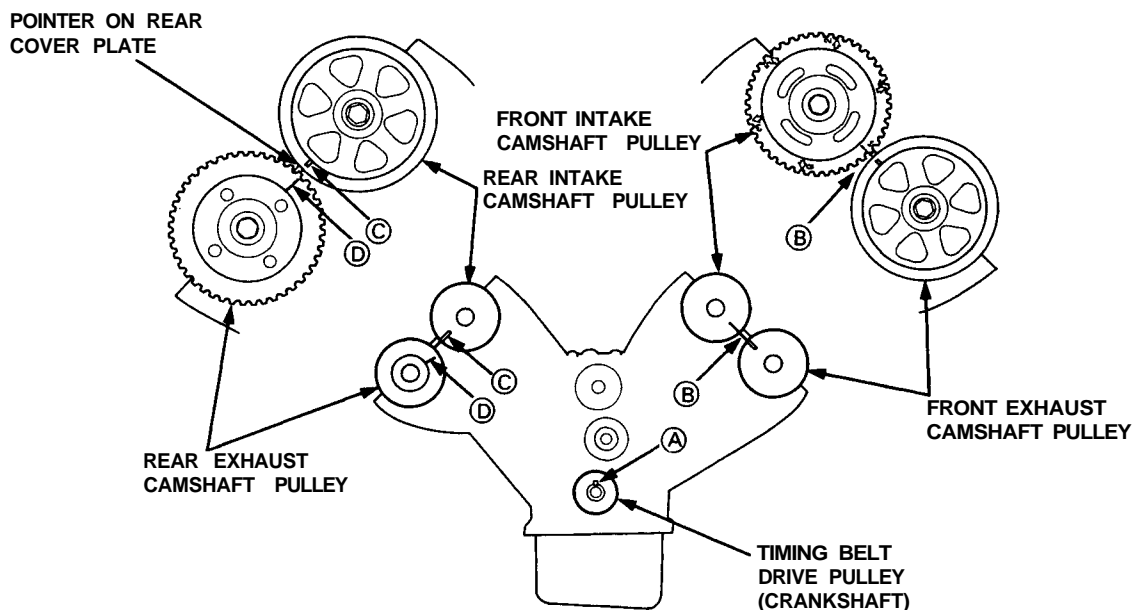

(cont'd)

# Timing Belt

## Installation (cont'd)

- Temporarily install the lower cover and crankshaft pulley.
- Check the crankshaft pulley and the camshaft pulleys at TDC.

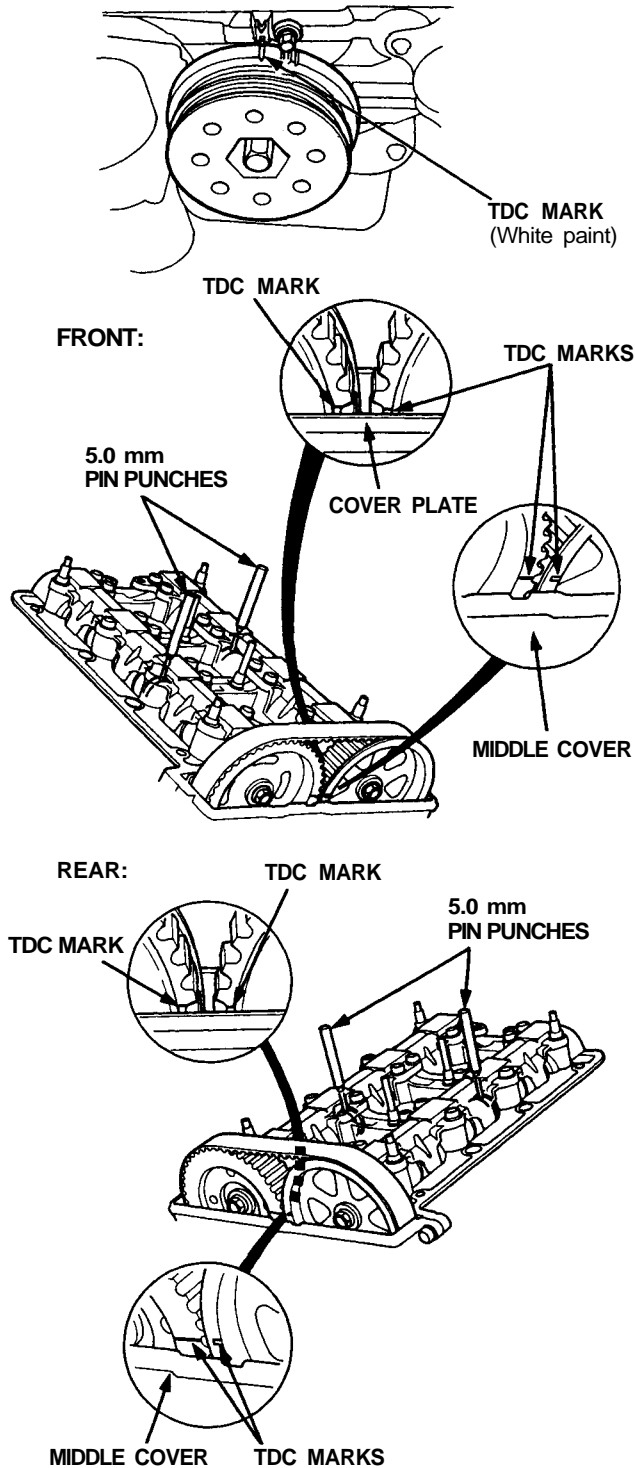

- If the camshaft pulleys are not positioned at TDC, remove the timing belt and adjust the positioning of the pulleys, then reinstall the timing belt.

### NOTE:

- Refer to page 6-23, 24 for timing belt removal.
- Bring the "UP" mark of the camshaft pulleys to the top, and align the TDC marks on the pulleys.
- Align the holes on the camshaft holder pipes to the camshaft holes, insert 5.0 mm pin punches and fix them at TDC.
- Remove the pin punches after the timing belt has been reinstalled.

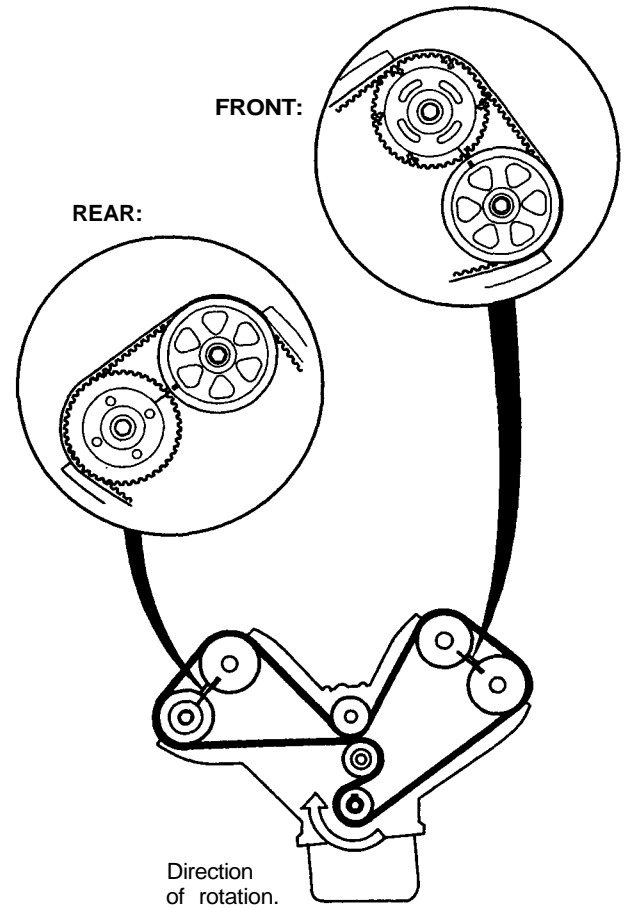

### NOTE:

- Prior to installing the cylinder head cover, apply a thin layer of liquid gasket to the mating surface of the cylinder head cover and rubber seals to prevent the rubber seal from falling off.
- After installation, fill the engine with oil up to the specified level, run the engine for more than 3 minutes, then check for oil leakage.