

Cylinder Heads

Removal

Engine removal is not required in this procedure.

CAUTION: To avoid damaging the cylinder heads, wait until the engine coolant temperature drops below 100°F (38°C) before loosening the retaining bolts.

NOTE:

- Inspect the timing belt before removing the cylinder heads.
- Turn the crankshaft so that the No. 1 piston is at top dead center (TDC (page 6-25, 26)).
- Mark all emission hoses before disconnecting them.

1. Disconnect the negative terminal from the battery.
2. Remove the expansion tank cap.

▲ WARNING Use care when removing the expansion tank cap to avoid scalding by engine coolant or steam.

3. Raise the car.
4. Remove the right rear wheel/tire.
5. Remove the engine under guard, then remove the front exhaust pipe.
6. Remove the rear exhaust pipe.

CAUTION: Do not use an air wrench or hammer to remove or install the exhaust system unless you first remove the heated oxygen sensors.

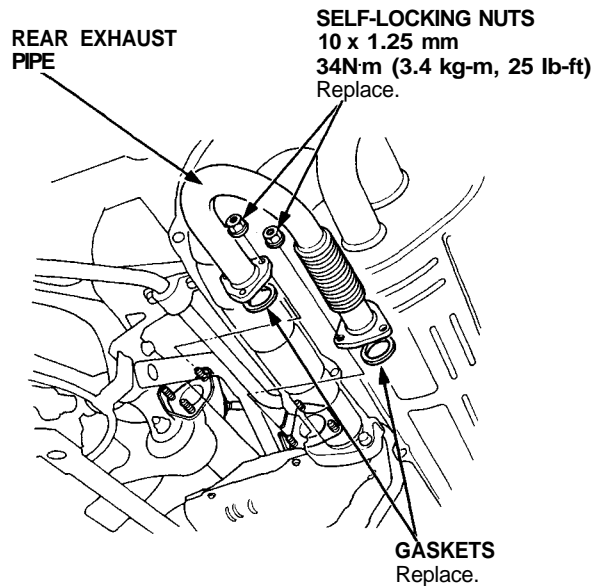
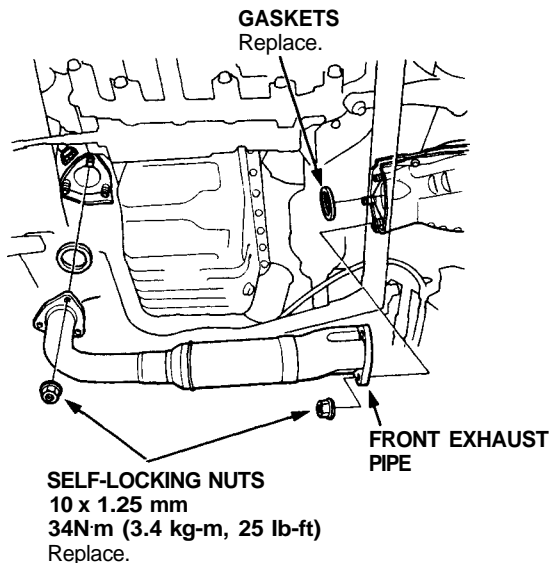

7. Remove the under cover, then remove the water pipe drain bolts and drain the engine coolant.
8. Attach the hoses to front and rear engine drain bolts, then loosen the bolts and drain the engine coolant.
 - Bleed air from the cooling system when installing the cylinder heads (page 10-5).
9. Remove the engine oil cooler base assembly (page 6-23).
10. Lower the car.
11. Remove the strut bar (page 5-19).
12. Remove the intake manifold plate and top cover (page 5-21).
13. Remove the throttle cable by loosening the locknut, then slip the cable and nut off the throttle bracket and throttle link (page 5-21).

NOTE:

- Take care not to bend the cable when removing it. Always replace a kinked cable with new one.
- Adjust throttle cable when installing (see section 11).



14. Relieve fuel pressure (see [section 11](#)).

⚠ WARNING Do not smoke while working on fuel system; keep open flame or spark away from work area. Drain fuel only into an approved container.

15. Disconnect the fuel feed pipe and the return hose (page [5-21](#)).

16. Remove the ignition coil covers, the wire harness covers, the ignition coils and the connectors (page [6-23](#)).

17. Remove the water hoses, then remove the expansion tank (page [5-21](#)).

18. Remove the breather hose, and the air cleaner housing (page [5-22](#)).

19. Remove the brake booster hose, the evaporative emission (EVAP) control canister hose and other hoses from the intake manifold and throttle body (page [5-22](#)).

20. Remove the emission control box (page [5-23](#)).

- Do not disconnect emission hose.
- Disconnect the three connectors before removing.

21. Remove the connector, the terminal and the alternator.

22. Disconnect the following engine wire harness connectors, then remove the harness clamps from the cylinder head and the intake manifold.

Front cylinder head:

- Crankshaft position (CKP)/cylinder position (CYP) sensor connector
- Air conditioning (A/C) compressor magnetic clutch connector
- Heated oxygen sensor (HO2S) connector
- Ground cable terminals

- Three injector connectors (cylinders No. 4, 5 and 6)
- Intake air temperature (IAT) sensor connector
- Ignition control module (ICM) connector
- Condenser connector
- Engine oil pressure gauge sending unit connector
- VTEC solenoid valve connector
- VTEC pressure switch connector
- Engine coolant temperature (ECT) sensor connector
- ECT sending unit connector
- Accelerator pedal opening sensor connector (throttle body)
- Radiator fan control sensor connector

Rear cylinder head:

- Engine oil pressure switch connector (oil cooler base)
- Heated oxygen sensor connector
- Three injector connectors (cylinders No. 1, 2 and 3)
- Idle air control (IAC) valve connector
- Knock sensor connector
- Throttle actuator motor connector
- Throttle position sensor connector
- VTEC solenoid valve connector
- VTEC pressure switch connector
- ICM connector
- Ground terminal

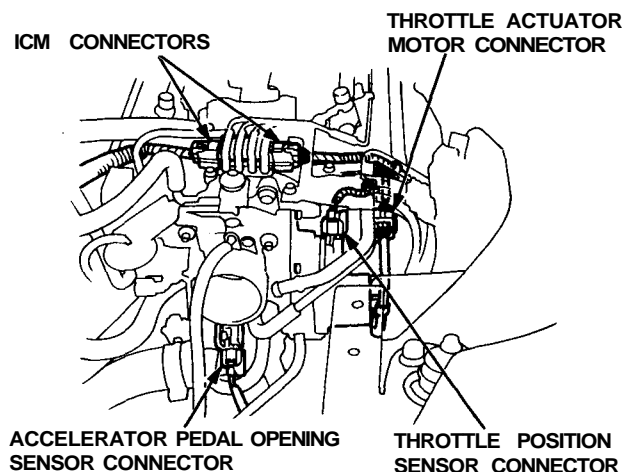

Cylinder Heads

Removal (cont'd)

23. Remove the exhaust gas recirculation (EGR) pipe and the intake manifold assembly.

NOTE: Fill the cylinder head intake ports with clean shop towels to prevent foreign materials from getting into the cylinders.

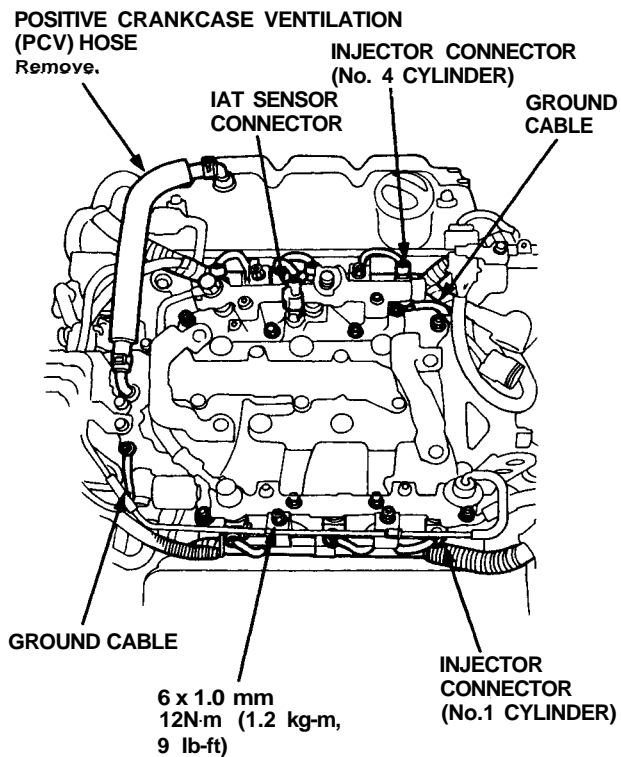
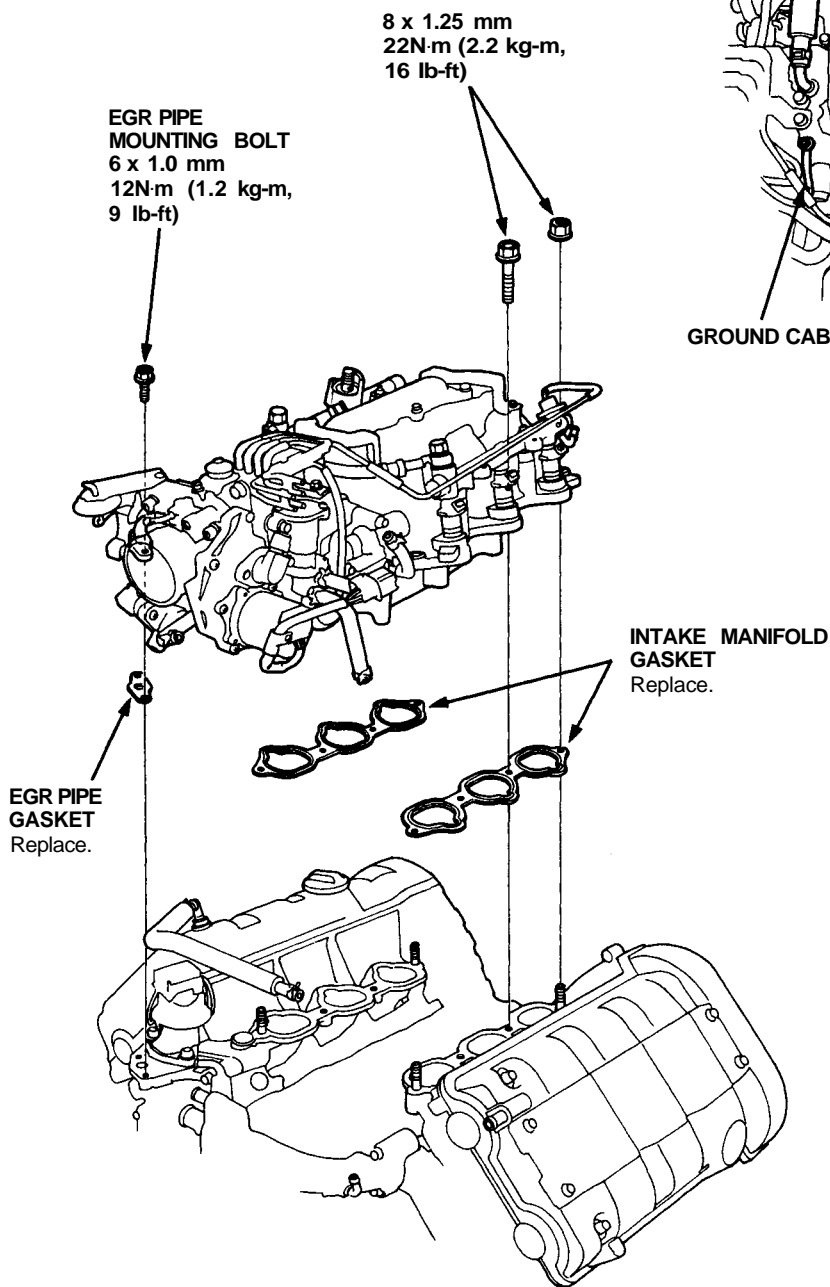



24. Remove the bolt from the side engine mount, then push the side mounting bracket into the housing of the body (page 5-27).
25. Remove the transmission mount.
26. Remove the alternator bracket stiffener (page 6-24).
27. Disconnect the knock sensor connectors, then remove the wire holder.

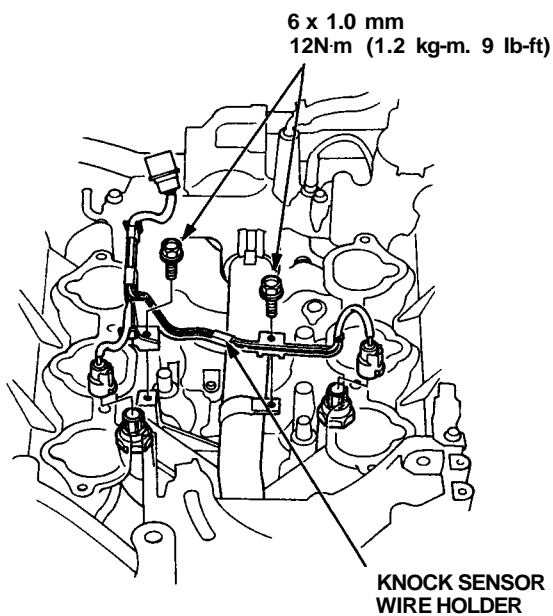

28. Remove the heater hose and the water hoses.

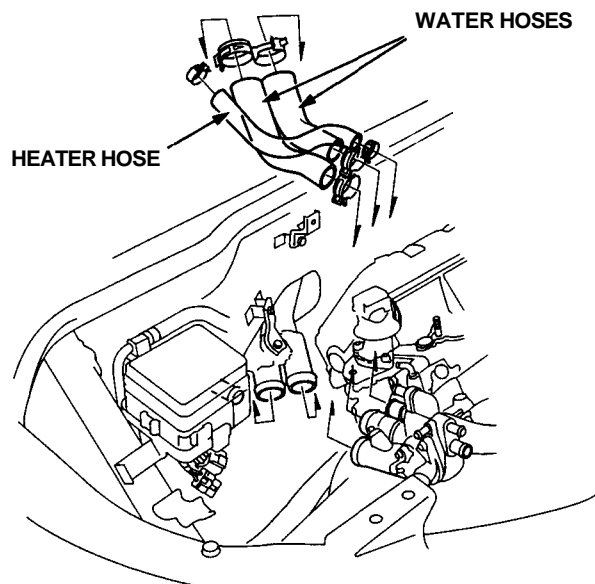

29. Remove the water passage.

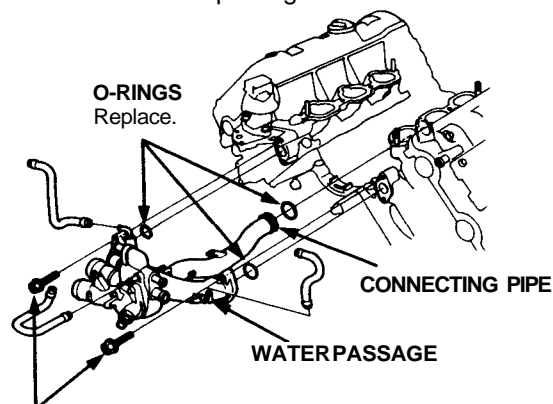

8 x 1.25 mm
22N·m (2.2 kg-m, 16 lb-ft)

30. Remove the cylinder head covers.
31. Turn the crankshaft so that the No. 1 piston is at top dead center (page 6-25, 26).
32. Install a brace under the engine, then tilt the engine approximately 5° using a jack (page 6-24).
33. Remove the alternator bracket.

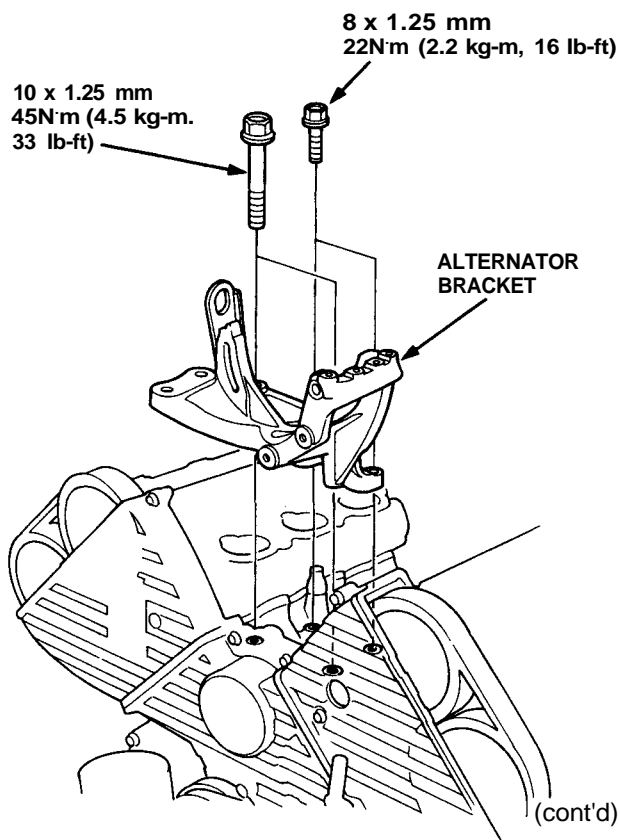

Cylinder Head

Removal (cont'd)

NOTE: Removal of the following items is not necessary if only the rear cylinder head is going to be removed.

- A/C compressor adjusting pulley and A/C compressor belt
- Timing belt lower cover
- Crankshaft pulley

34. Remove the A/C compressor adjusting pulley and belt.

33. Remove the dipstick pipe mounting bolt, then remove the front and rear timing belt middle covers.

35. Remove the crankshaft pulley, then remove the timing belt lower cover.

36. Loosen the timing belt adjusting bolt 180° and release the belt tension.

NOTE: Push the tensioner to release tension from the belt, then retighten the adjusting bolt.

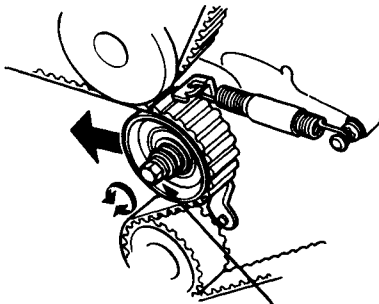

ADJUSTING BOLT
Do not remove.
Loosen it 180°.

37. Remove the timing belt from the pulleys.

CAUTION: Do not crimp or bend the timing belt more than 90° or less than 25 mm (1 in) in diameter.

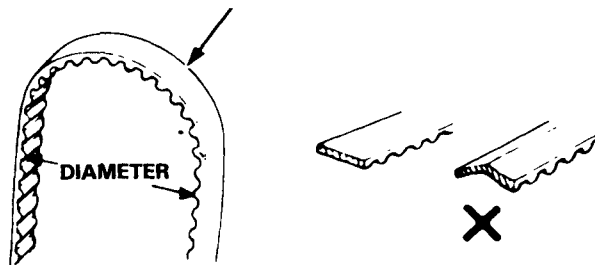

38. Remove the camshaft pulleys.

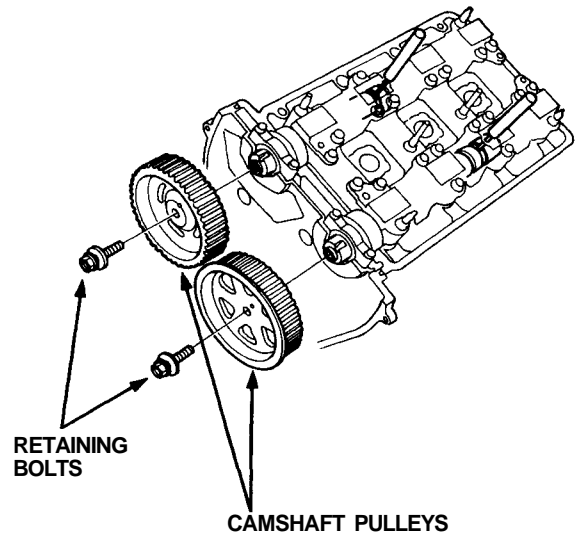

39. Remove the front and rear timing belt cover plates.

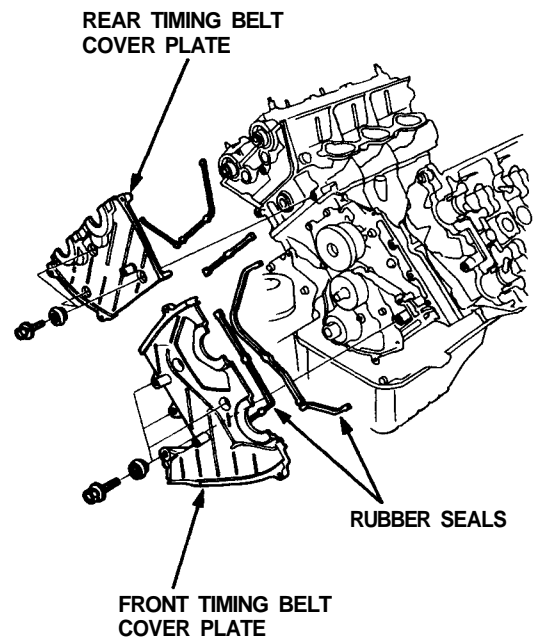



40. Loosen the valve locknuts and the adjusting screws.
41. Remove the camshaft holder pipes, the camshaft holders and the camshafts.

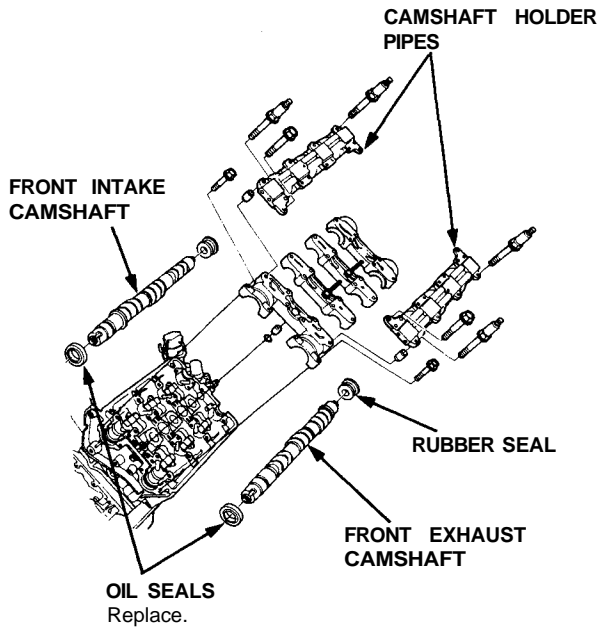

42. Screw a 5 mm bolt into each rocker shaft orifice, then pull out the rocker shaft orifices.

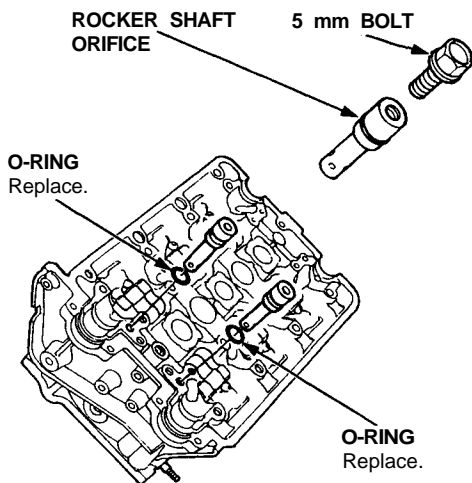

43. Remove the VTEC valve assemblies.
44. Remove the sealing bolts.

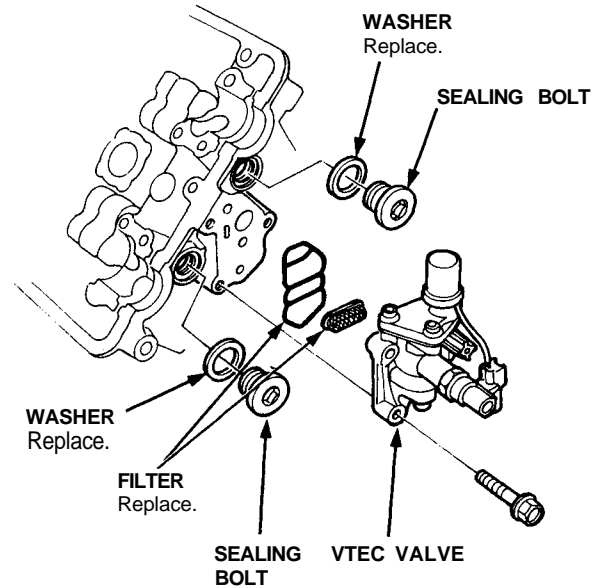

45. Bundle the rocker arms with rubber bands to keep them together as sets.
46. Screw a 12 x 1.25 mm bolt into each rocker shaft. Remove the rocker arms while slowly pulling the rocker shafts out of the cylinder heads toward the transmission.

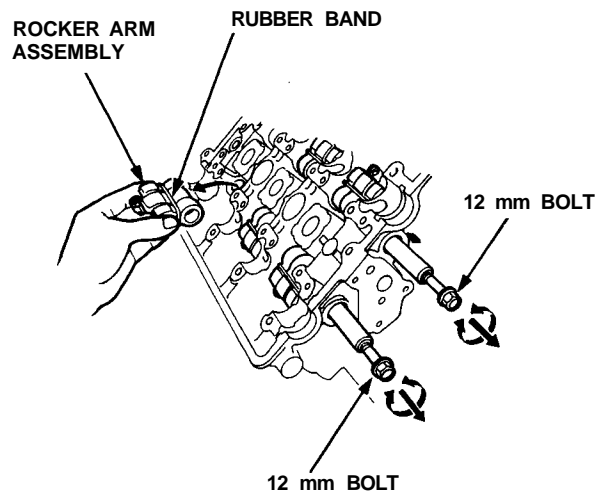

(cont'd)

Cylinder Heads

Removal (cont'd)

47. Disconnect the connectors and remove the engine wire harness.
48. Remove the cylinder head bolts, then remove the cylinder heads.
CAUTION: To prevent warpage, unscrew the bolts in sequence 1/3 turn at a time; repeat the sequence until all bolts are loosened.

CYLINDER HEAD BOLTS LOOSENING SEQUENCE

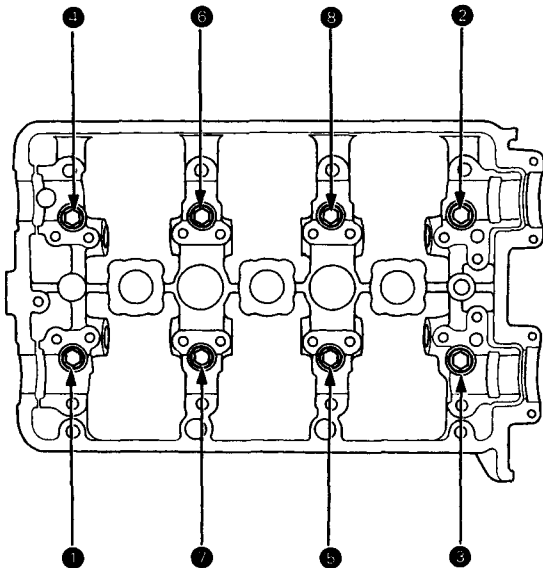

NOTE: Separate the cylinder head from the block with a flat blade screwdriver as shown.

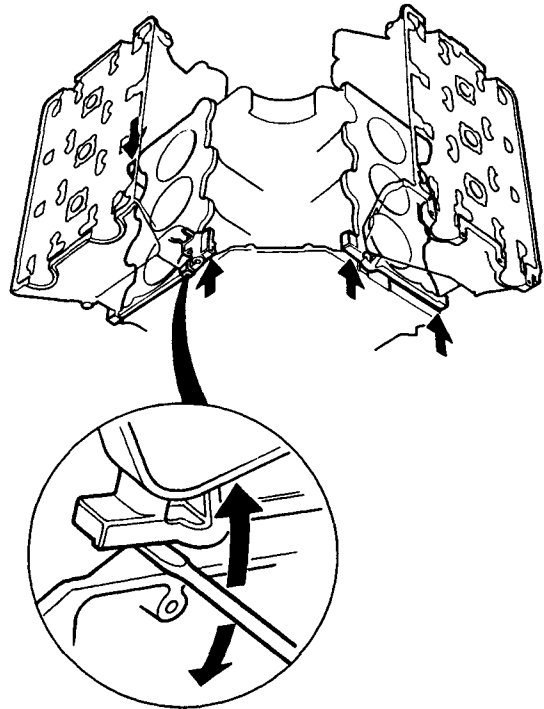

49. Remove the front and rear exhaust manifold covers, then remove the front and rear exhaust manifolds.

CAUTION: Do not use an air wrench or hammer to remove the exhaust system unless you first remove the heated oxygen sensor.