

Valve Seats

Reconditioning

1. Renew the valve seats in the cylinder head using a valve seat grinder.

NOTE: If guides are worn (page 6-43), replace them (page 6-44) before grinding the valve seats.

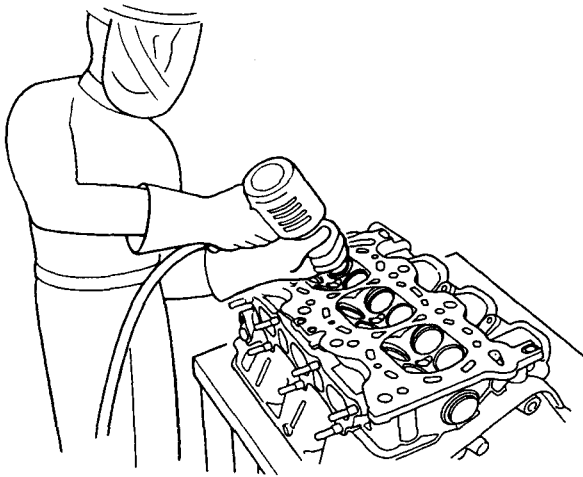

2. Carefully grind a 45° seat, removing only enough material to ensure a smooth and concentric seat.
3. Bevel the upper edge of the seat with the 30° stone and the lower edge of the seat with the 60° stone. Check width of seat and adjust accordingly.
4. Make one more very light pass with the 45° stone to remove any possible burrs caused by the other stones.

Valve Seat Width:

Standard: IN 0.80-1.00 mm (0.031-0.039 in)

EX 1.25-1.55 mm (0.049-0.061 in.)

Service Limit: IN 1.5 mm (0.059 in)

EX 2.0 mm (0.079 in)

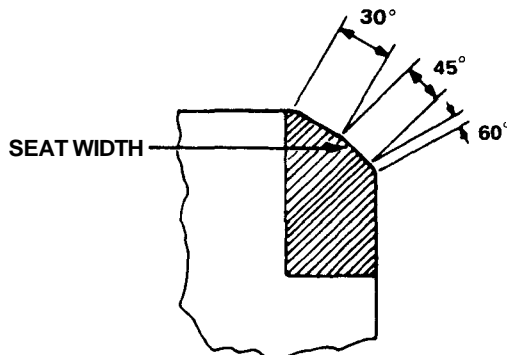

5. After resurfacing the seat, inspect for even valve seating: Apply Prussian Blue compound to the valve face, and insert valve in original location in the head, then lift it and snap it closed against the seat several times.

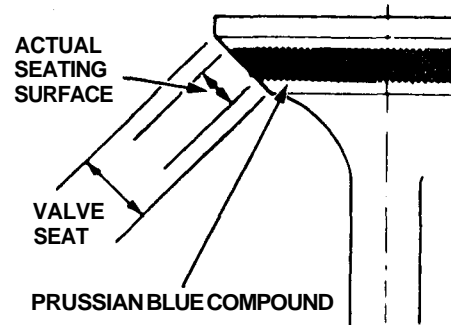

6. The actual valve seating surface, as shown by the blue compound, should be centered on the seat.
 - If it is too high (closer to the valve stem), you must make a second cut with the 60° stone to move it down, then one more cut with the 45° stone to restore seat width.
 - If it is too low (closer to the valve edge), you must make a second cut with the 30° stone to move it up, then one more cut with the 45° stone to restore seat width.

NOTE: The final cut should always be made with the 45° stone.

7. Insert intake and exhaust valves in the head and measure valve stem installed height.

Valve Stem Installed Height (IN and EX):

Standard (New): 41.55-42.35 mm

(1.6358-1.6673 in)

Service Limit: 42.435 mm (1.6707 in)

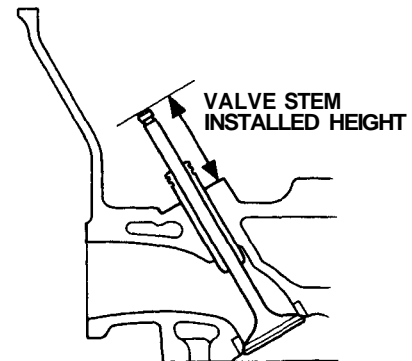

8. If valve stem installed height is over the service limit, replace valve and recheck. If still over the service limit, replace cylinder head; the valve seat in the head is too deep.