

Valve Guides

Replacement

1. As illustrated in the removal steps of this procedure, use a commercially—available air-impact driver attachment modified to fit the diameter of the valve guides. In most cases, the same procedure can be done using the Valve Guide Driver and a conventional hammer.

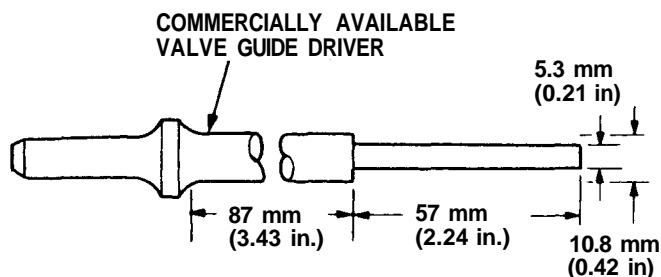

Removal and Installation
VALVE GUIDE DRIVER
07742-0010100

2. Select the proper replacement guides and chill them in the freezer section of a refrigerator for about an hour.
3. Use a hot plate or oven to evenly heat the cylinder head to 300°F (150°C). Monitor the temperature with a cooking thermometer.

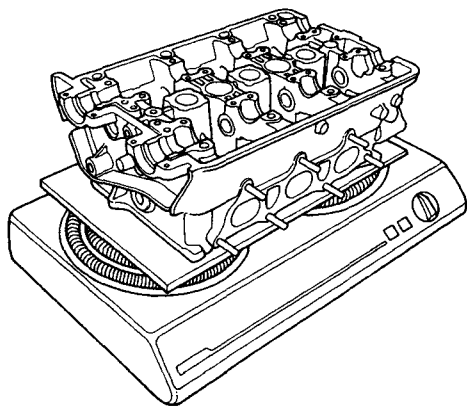

CAUTION:

- Do not use a torch; it may warp the head.
- Do not get the head hotter than 300°F (150°C) excessive heat may loosen the valve seats.
- To avoid burns, use heavy gloves when handling the heated cylinder head.

4. Working from the camshaft side, use the driver and an air hammer to drive the guide about 2 mm towards the combustion chamber. This will knock off some of the carbon and make removal easier.



VALVE GUIDE DRIVER
07742-0010100

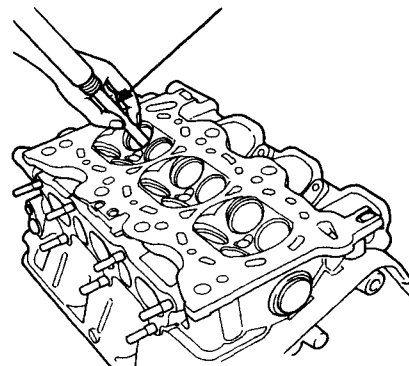

CAUTION:

- Always wear safety goggles or a face shield when using the air hammer.
- Hold the air hammer directly in line with the valve guide to prevent damaging the driver.

5. Turn the head over and drive the guide out toward the camshaft side of head.

If a valve guide still won't move, drill it out with a 5/16 inch bit, then try again.

CAUTION: Drill guides only in extreme cases: you could damage the cylinder head if the guide breaks.

6. Remove the new guide(s) from the refrigerator, one at a time, as you need them.



- Slip a 6 mm steel washer and the correct driver attachment over the end of the driver (The washer will absorb some of the impact and extend the life of the driver).

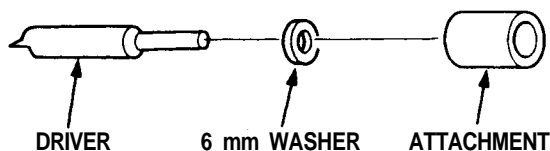

- Install the new guide(s) from the camshaft side of the head; drive each one in until the attachment bottoms on the head. If you have all twelve guides to do, you may have to reheat the head one or two more times.

VALVE GUIDE DRIVER, 5.5 mm
07742-0010100

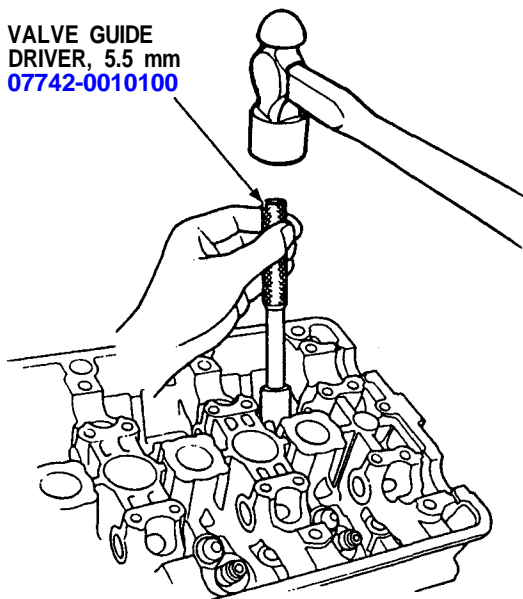

Valve Guide Installed Height:

Intake: 13.75-14.25 mm (0.541-0.561 in)

Exhaust: 13.75-14.25 mm (0.541-0.561 in)

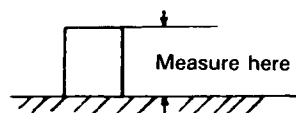

Valve Guide Reaming

NOTE: For new valve guides only.

- Coat both reamer and valve guide with cutting oil.
- Rotate the reamer clockwise the full length of the valve guide bore.
- Continue to rotate the reamer clockwise while removing it from the bore.
- Thoroughly wash the guide in detergent and water to remove any cutting residue.
- Check clearance with a valve (page 6-43).
 - Verify that the valve slides in the IN, EX valve guides without exerting pressure.

REAMER HANDLE

VALVE GUIDE REAMER, 5.5 mm
07HAH-PJ7010A

