



# Rocker Arms

## Installation

Install the rocker arms in the reverse order of removal:

- Valve adjusting lockouts should be loosened and adjusting screws backed off before installation.
- The component parts must be installed in the original locations.

1. Install the lost motion assemblies.
2. Install the rocker arms while passing the rocker arm shaft through the cylinder head.

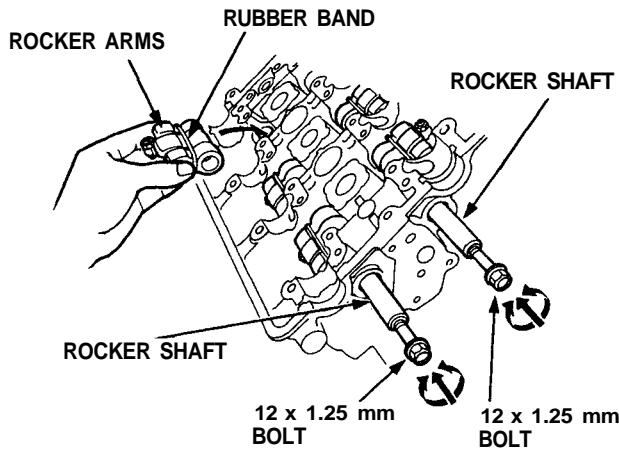

3. Install the orifices. If the holes in the rocker arm shafts and the cylinder head are not in line with each other, use a 12 x 1.25 mm bolt in the rocker arm shaft to rotate the shaft.

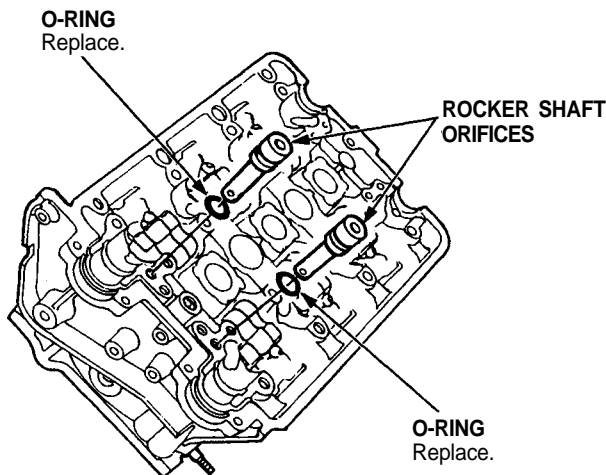

### CAUTION:

- After installing the rocker shaft orifice, try to turn the rocker shaft to make sure that the orifice has been inserted in the hole of rocker shaft correctly. If the orifice is in place, it should not turn.
- Remove the rubber bands after installing the rocker arms.

# Camshafts

## Installation

**CAUTION:** Valve locknuts should be loosened and adjusting screws backed off before installation.

1. After wiping down the cam and journals in cylinder head, lubricate both surfaces and install camshaft.
2. Turn the camshaft until its keyway is facing up. (No. 1 cylinder TDC).
3. Set a new O-ring and a dowel pin in the oil passage of the No. 1 camshaft holder.

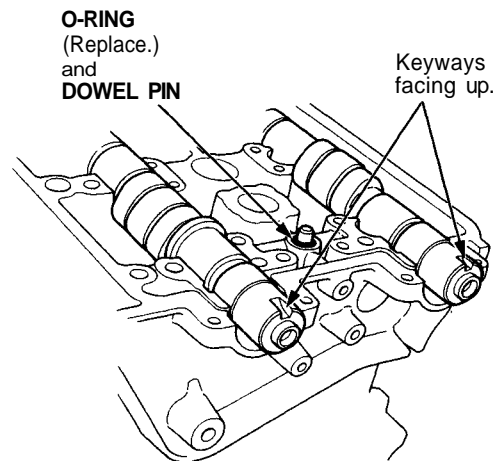

4. Install the camshaft seal with the open side (spring) facing in.

 Lubricate cam lobes after reassembly.

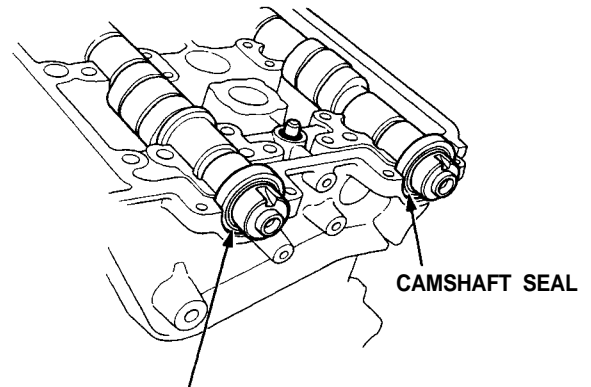

Seal housing surface should be dry. Apply a light coat of oil to camshaft and inner lip of seal.

(cont'd)

# Camshafts

## Installation (cont'd)

- Apply liquid gasket to the head mating surfaces of the No. 1 and the No. 4 camshaft holders.  
Apply liquid gasket to the shaded areas.
- Place the camshaft holders.

**NOTE:**

- "F" or "R" marks are stamped on the camshaft holders.
- The arrows must be pointing to the timing belt side.
- Set two dowel pins in each camshaft holder.

**FRONT:**

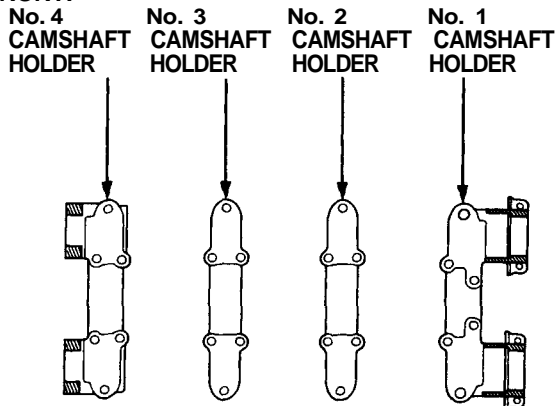

**REAR:**

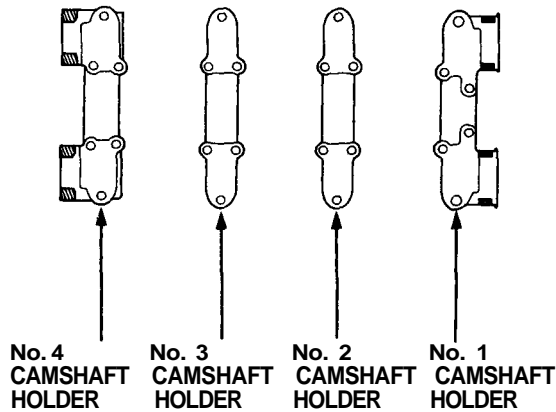

- Place the cam holder pipes.
- Tighten each bolt two turns at a time in the sequence shown below to insure that the rockers do not bind on the valves.

**NOTE:** Apply clean engine oil to 8 mm bolt threads.

**Specified torque:**

- ①-⑳ 8 mm x 1.25 mm bolts:  
22 N·m (2.2 kg-m, 16 lb-ft)
- ㉕-㉘ 6 mm x 1.0 mm bolts:  
10 N·m (1.0 kg-m, 7 lb-ft)

**CAMSHAFT HOLDER BOLT TORQUE SEQUENCE**

**FRONT:**

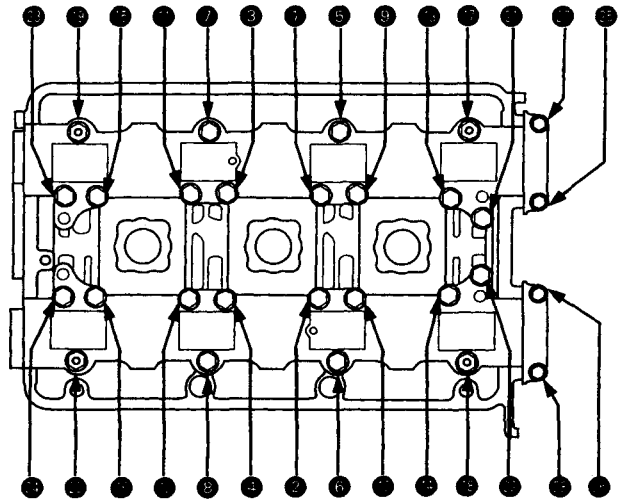

**REAR:**

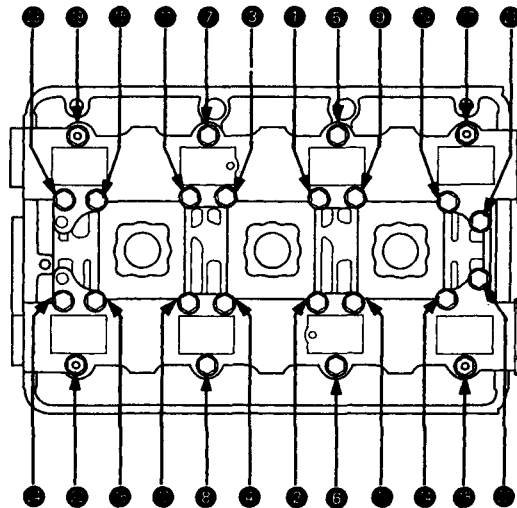



9. Install the CKP/CYP sensor on the front cylinder head.

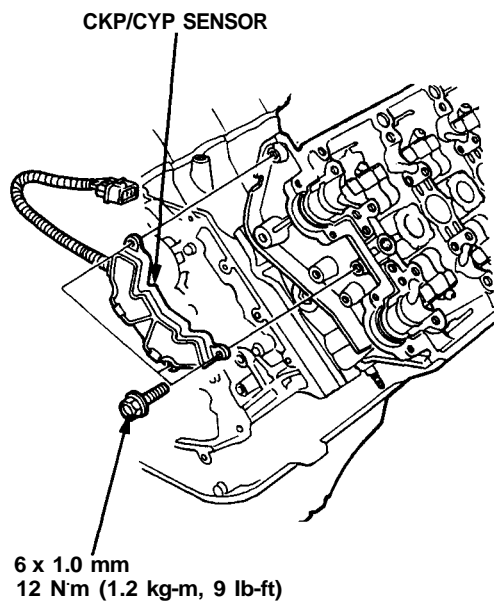

10. Install the front and rear timing cover plates.

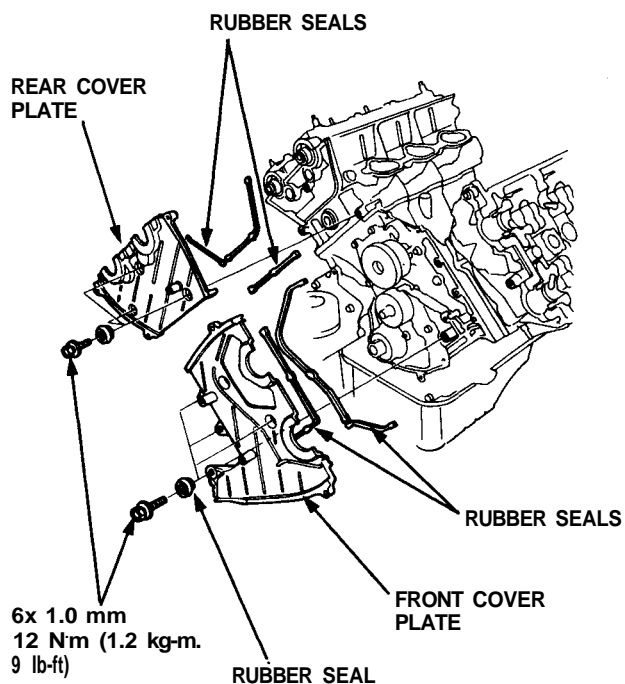

11. Insert the dowel pins in the camshaft pulley.
12. Install the camshaft pulleys then tighten the retaining bolts to the torque specified.

NOTE: To set the camshafts at TDC, align the camshaft holes with the camshaft holder pipe holes and insert 5.0 mm pin punches as shown.

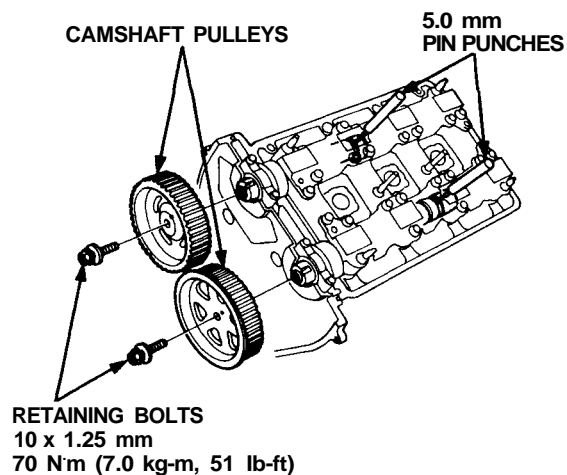

13. Install the timing belt (page 6-25, 26).
14. Adjust the valve clearance (page 6-54).
15. Inspect the rocker arms (pages 6-52, 53).
16. After installation, check that hoses and connectors are installed correctly.

NOTE:

- Prior to installing the cylinder head cover, apply a thin layer of liquid gasket to the mating surface of the cylinder head cover and rubber seals to prevent the rubber seal from falling off.
- After installation, fill the engine with oil up to the specified level, run the engine for more than 3 minutes, then check for oil leakage.