

Rocker Arms

Manual Inspection

1. Remove the ignition coil covers (page 6-23).
2. Remove the ignition coils (page 6-23).
3. Remove the cylinder head covers (page 6-3).
4. Set the No. 1 piston at top dead center (TDC) (page 6-26).
5. Push the mid rocker arm on the No.1 cylinder manually.
6. Check that the mid rocker arm moves independently of the primary and secondary rocker arms.

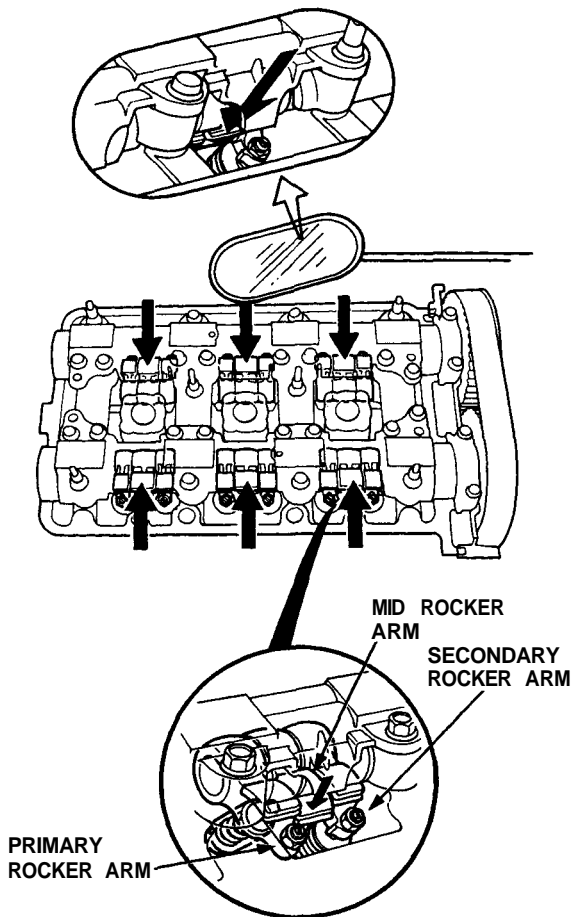

NOTE:

- Check the mid rocker arm of each cylinder at TDC.
- If the mid rocker arm does not move, remove the mid, primary and secondary rocker arms as an assembly and check that the pistons in the mid and primary rocker arms move smoothly.
 - Replace the rocker arms as an assembly if there is any abnormality.

Inspection Using Special Tools

CAUTION:

- Before using the special tool, make sure that the air pressure gauge on the air compressor indicates over 250 kPa (2.5 kg/cm², 36 psi).
- Inspect the valve clearance before rocker arm inspection.
- Cover the timing belt with a shop towel to protect the belt from oil.
- Check the mid rocker arm of each cylinder at TDC.

1. Plug the relief hole with the special tool as shown.

Front cylinder head:

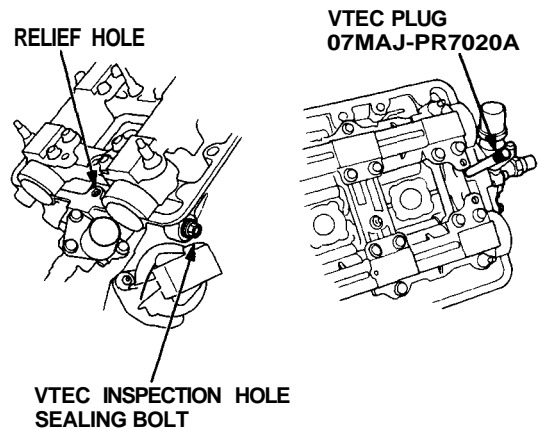

Rear cylinder head:

