



# Transmission

## Reassembly

1. Install the oil seal, shift arm, and shift lever in the transmission housing.

8 x 1.0 mm SPECIAL BOLT  
32 N-m (3.2 kg-m, 23 lb-ft)

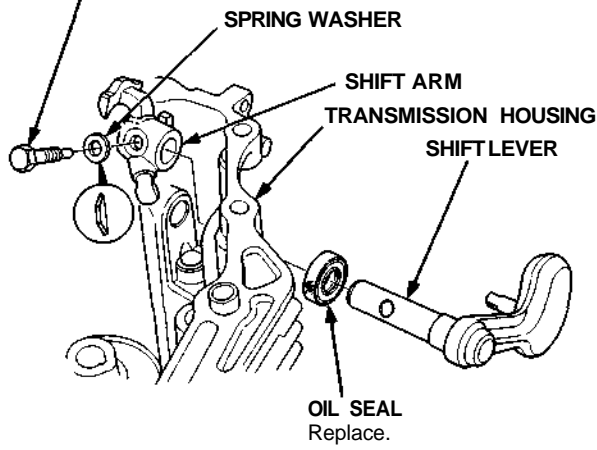

2. Install the shift detent spring and spring set plate.

8 x 1.25 mm SPECIAL BOLT  
26 N-m (2.6 kg-m, 19 lb-ft)

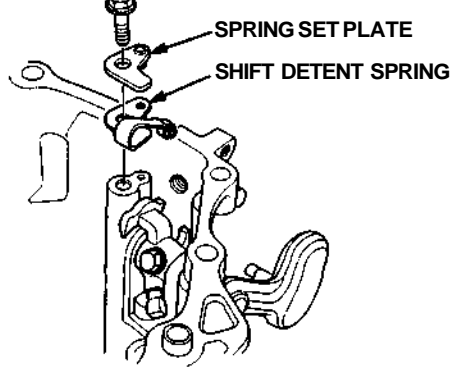

3. Install the oil seal, select arm, and select lever in the clutch housing.

8 x 1.0 mm SPECIAL BOLT  
32 N-m (3.2 kg-m, 23 lb-ft)

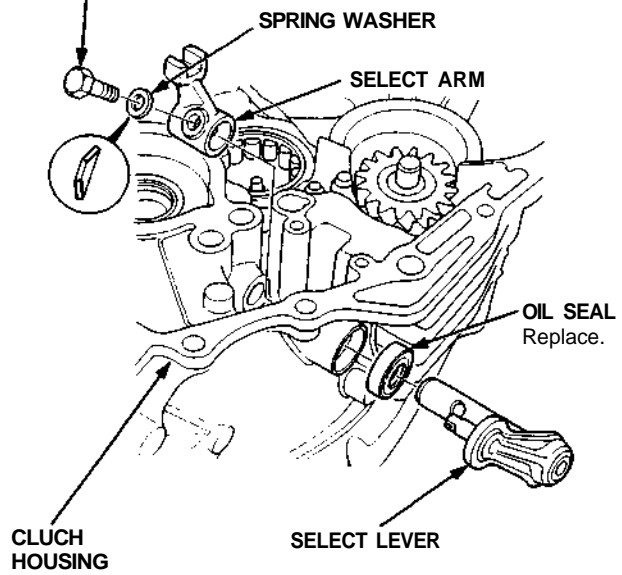

4. Install the differential assembly into the clutch housing.

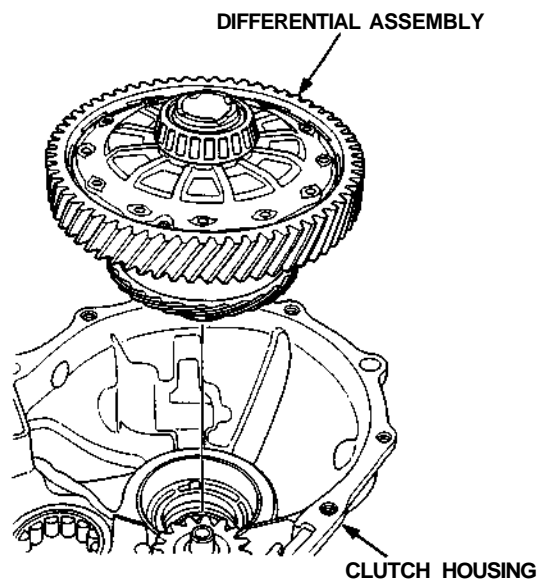

(cont'd)

# Transmission

## Reassembly(cont'd)

5. Install the spring washer, then insert the mainshaft and countershaft into the shift forks and install them as an assembly.

NOTE: Tape the mainshaft spline before installation.

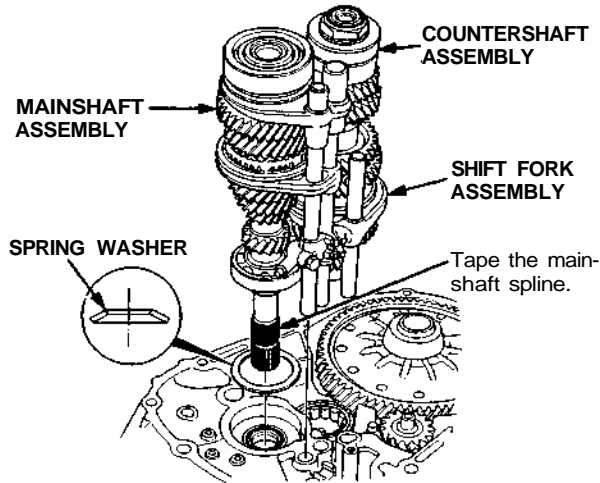

6. Install the change holder assembly in the clutch housing.

NOTE: Place the interlock finger in the groove of the select arm.

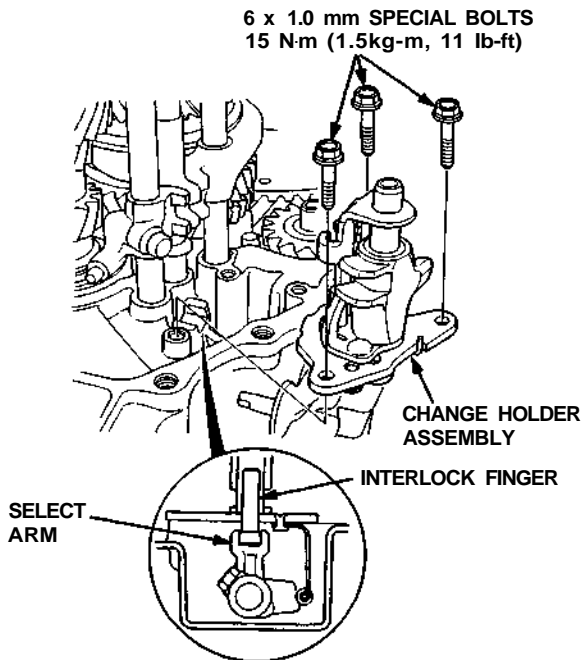

7. Lift the mainshaft assembly, then install the reverse idle gear shaft assembly with the spring pin matching the groove of the clutch housing.

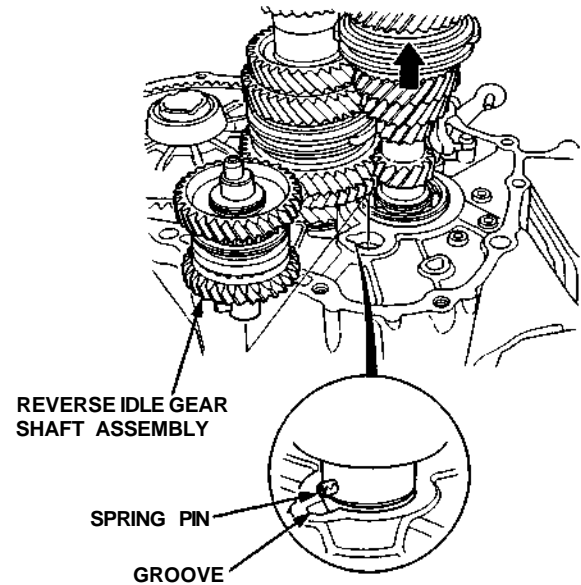

8. Shift the reverse synchro sleeve to the driven gear side. Lift the mainshaft assembly and reverse idle gear shaft assembly, then install the reverse shift fork assembly.

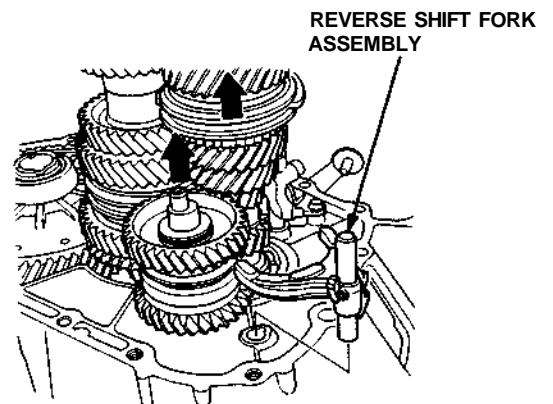



9. Install the reverse shift arm.

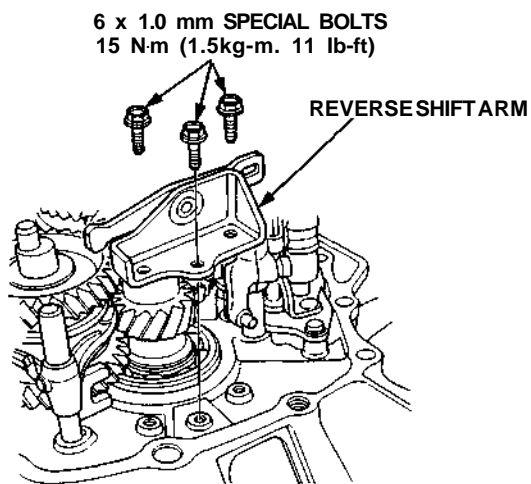

10. Apply liquid gasket to the surface of the transmission housing mating with the clutch housing as shown.

**NOTE:**

- Use liquid gasket (P/N 08718-0001).
- Remove the dirt oil from the sealing surface.
- Seal the entire circumference of the bolt hole to prevent oil leakage.
- If 20 minutes have passed after applying liquid gasket, reapply it and assemble the housings.
- Refill the oil after 30 minutes after replacement.

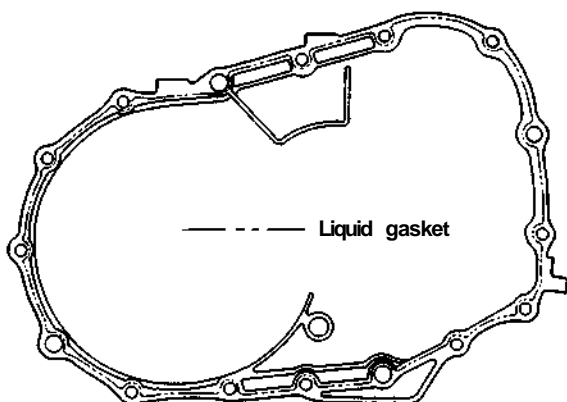

11. Install the dowel pins on the clutch housing.

12. Place the transmission housing over the clutch housing, being careful to line up the shafts.

**NOTE:** Make sure the 3rd/4th shift fork shaft collar mates with the 3rd/4th shift fork shaft.

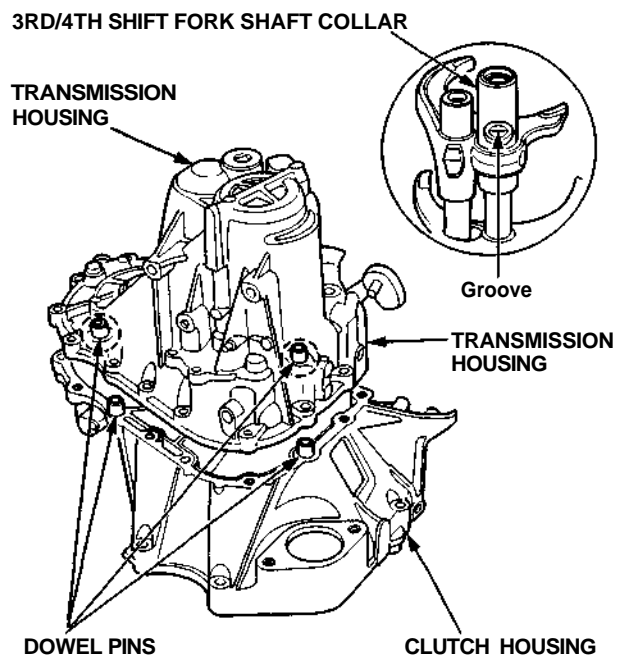

a. Place the shift lever as a shown.

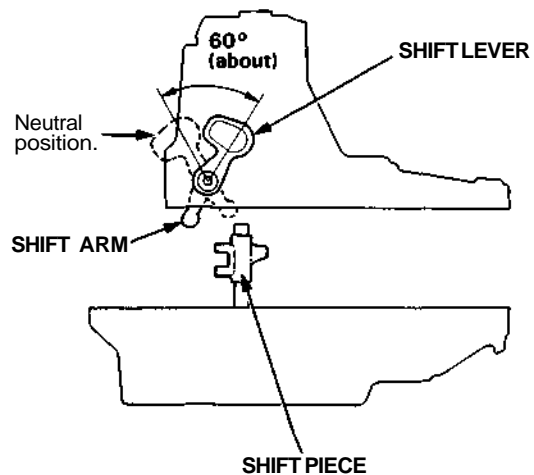

(cont'd)

# Transmission

## Reassembly (cont'd)

- b. Lower the transmission housing, then place the shift arm in the groove of the shift piece by turning the shift lever.

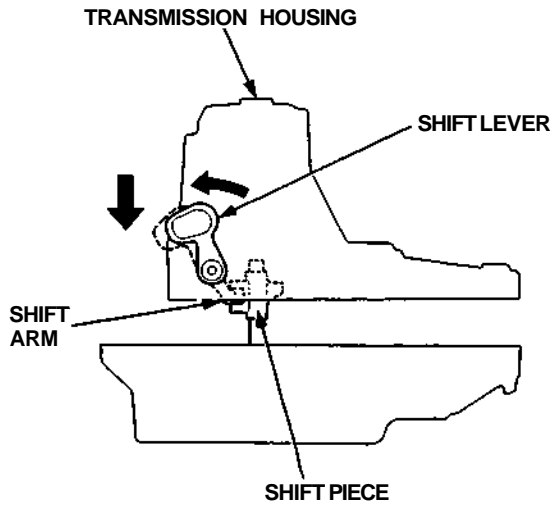

- c. Check the operation of the shift lever.

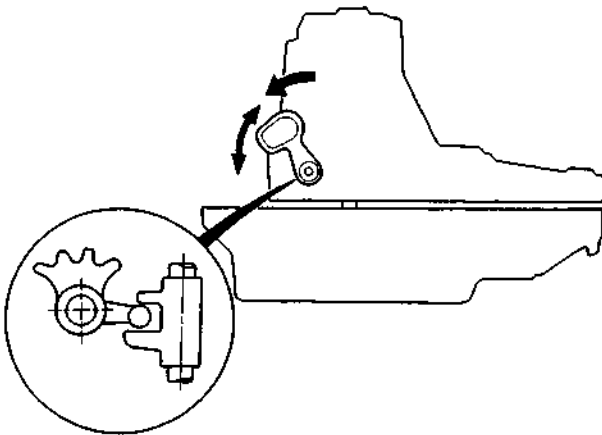

13. Lower the transmission housing with the snap ring plier and set the snap ring in the groove of the countershaft bearing.

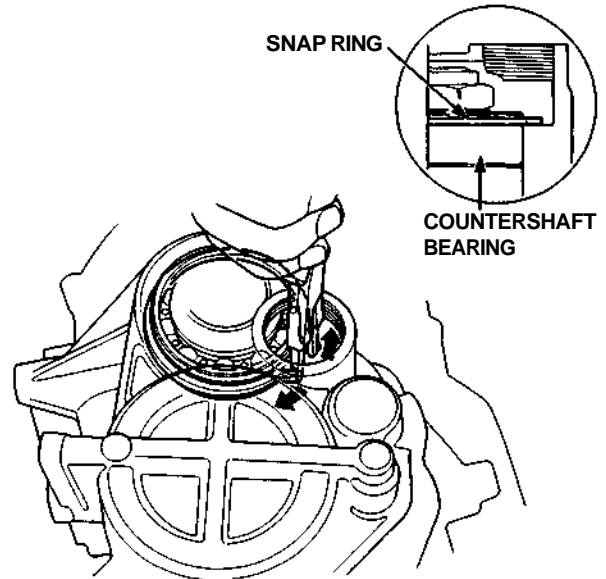

14. Check that the snap ring is securely seated in the groove of the countershaft bearing.

**Dimension A as installed: 1.60–8.15 mm  
(0.063–0.321 in)**

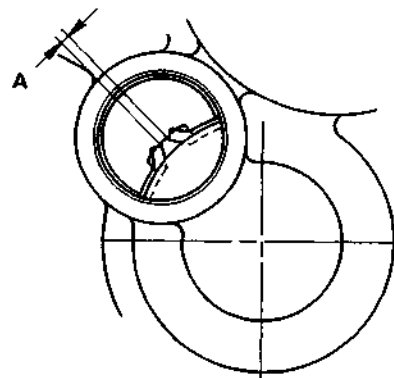



15. Tighten the transmission housing attaching bolts in a criss-cross pattern in several steps shown below.

**Torque: 45 N·m (4.5 kg-m, 33 lb-ft)**

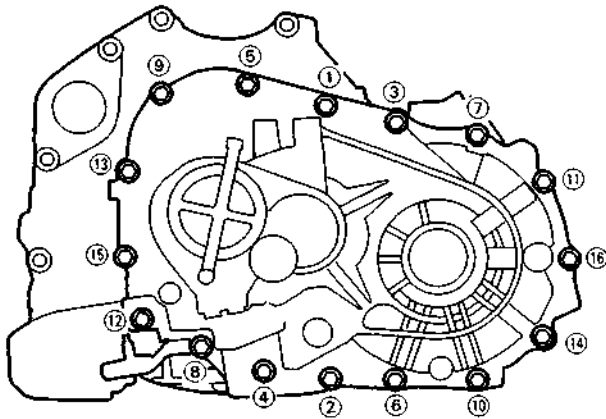

16. Install the 36 mm sealing bolt.

NOTE: Apply liquid gasket (P/N 08718-0001) to the flange.

17. Install the steel balls, springs, and sealing bolts.

NOTE: Apply liquid gasket (P/N 08718-0001) to the threads, but don't plug the hole with liquid gasket.

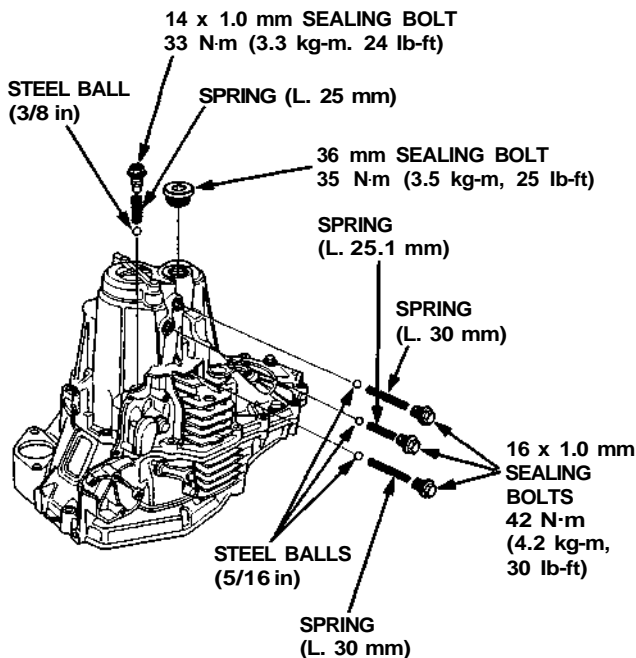

18. Install the back-up light switch and neutral position switch.

NOTE: Apply liquid gasket (P/N 08718-0001) to the threads.

19. Install the vehicle speed sensor (VSS).

