

Main Valve Body

Disassembly/Inspection/Reassembly

NOTE:

- Clean all parts thoroughly in solvent or carburetor cleaner, and dry with compressed air.
- Blow out all passages.
- Replace valve body as an assembly if any parts are worn or damaged.
- Check all valves for free movement. If any fail to slide freely, see Valve Body Repair on page 14-109.
- Coat all parts with ATF before reassembly.
- Adjust and select the manual valve detent spring when the manual valve or manual valve detent spring is replaced. See page 14-146.

CAUTION: Do not use a magnet to remove the check balls; it may magnetize the balls.

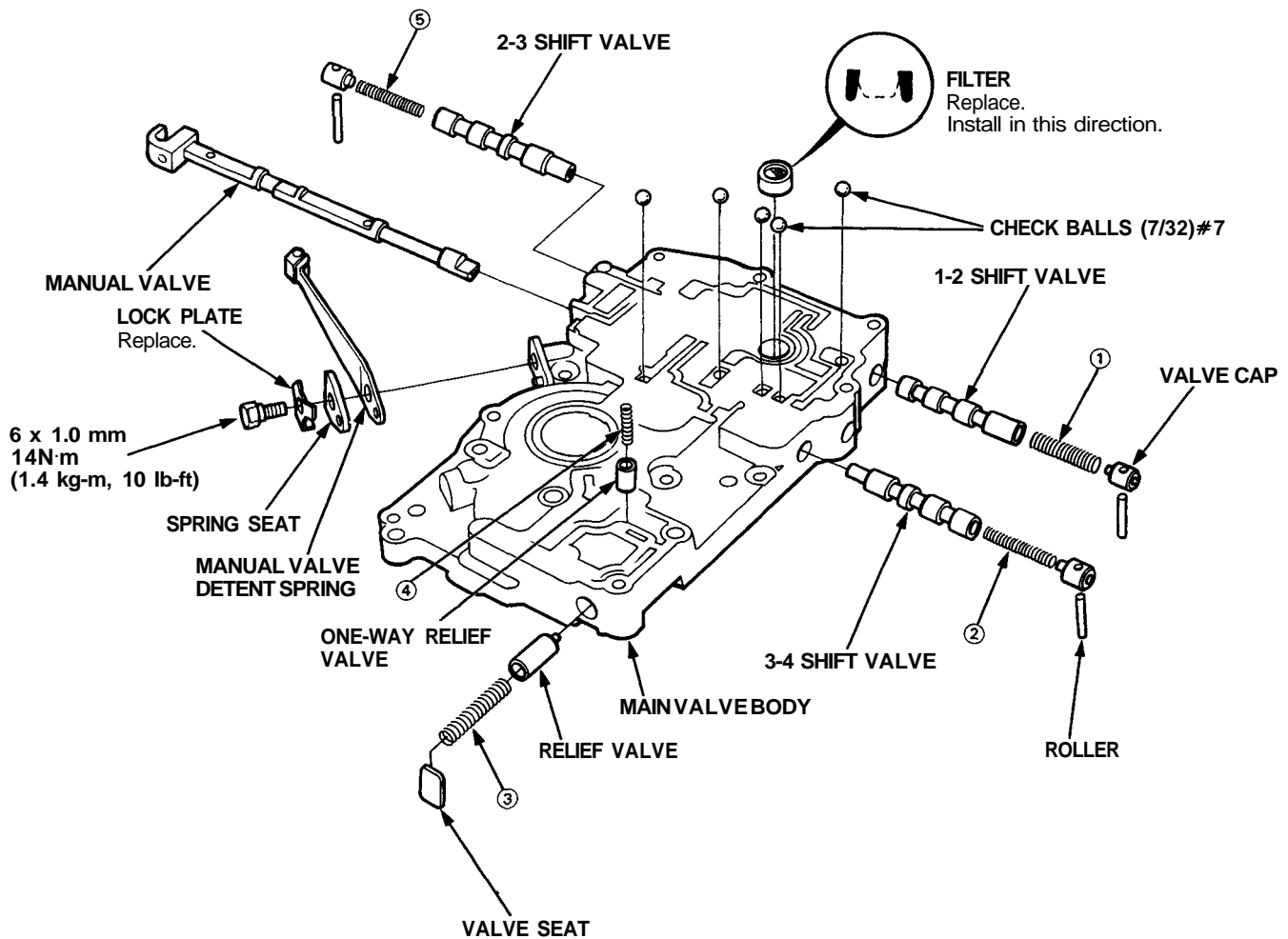



NOTE: All check balls are the same size (7/32)#7.

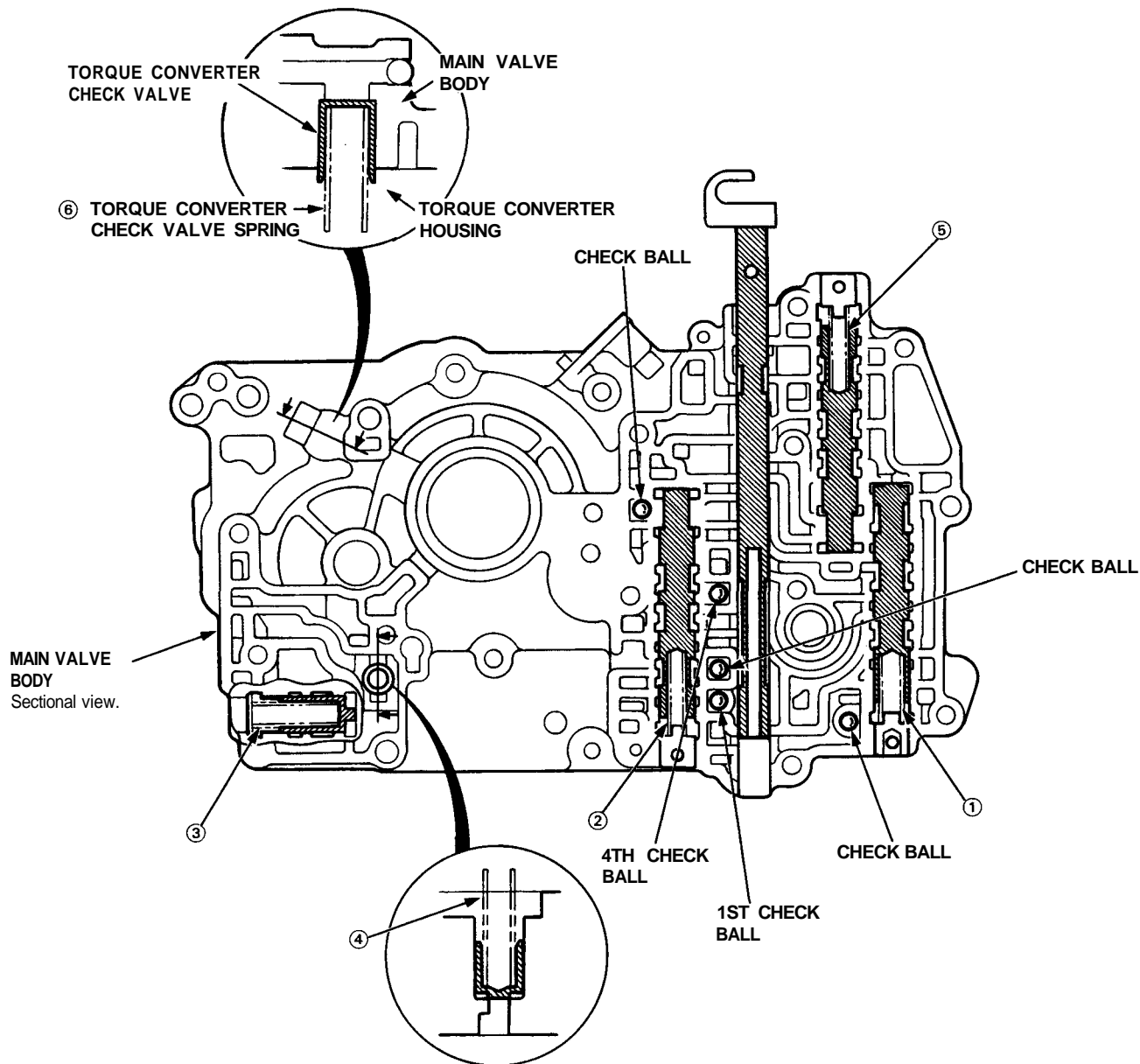

SPRING SPECIFICATIONS

Unit of length: mm (in)

No.	Spring	Standard (New)			
		Wire Dia.	O.D.	Free Length	No. of Coils
①	1-2 shift spring	0.9 (0.035)	8.6 (0.339)	40.4 (1.591)	14.5
②	3-4 shift spring	0.8 (0.031)	7.0 (0.276)	43.7 (1.720)	21.2
③	Relief valve spring	1.1 (0.043)	8.4 (0.331)	44.4 (1.748)	19.5
④	One-way relief valve spring	0.9 (0.035)	6.4 (0.252)	25.1 (0.988)	11.9
⑤	2-3 shift spring	0.8 (0.031)	7.0 (0.276)	43.7 (1.720)	21.2
⑥	Torque converter check valve spring	1.1 (0.043)	8.4 (0.331)	41.8 (1.646)	15.7