

Steering Wheel

Removal

Airbag Removal

▲ WARNING Store a removed airbag assembly with the pad surface up, if the airbag is improperly stored face down, accidental deployment could propel the unit with enough force to cause serious injury.

NOTE: Before removing the steering wheel, make sure the front wheels are straight ahead.

CAUTION:

- All SRS wiring harnesses are covered with yellow outer insulation.
- Before disconnecting any part of the SRS wire harness, install the short connectors (see pages 23-328 and 329).
- Replace the entire affected SRS harness assembly if it has an open circuit or damaged wiring.

1. Disconnect both the negative cable and positive cable from the battery.
2. Remove the access panel from the steering wheel lower cover, then remove the short connector.
3. Disconnect the connector between the airbag and cable reel.
4. Connect the short connector to the airbag side of the connector.

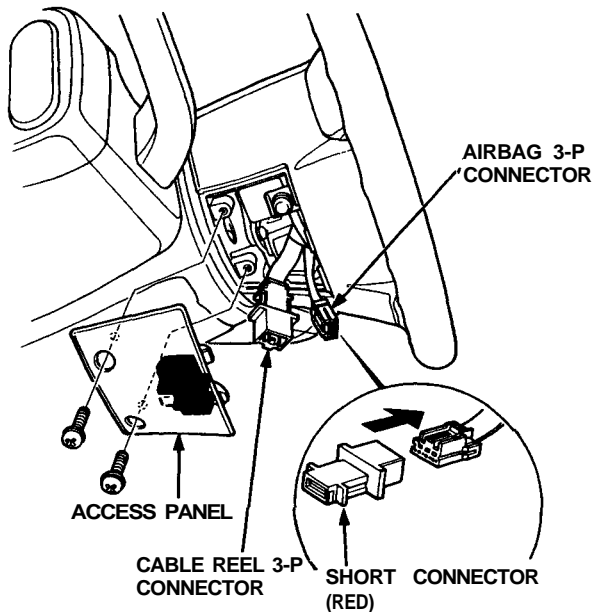

5. Remove the TORX® bolts using a TORX® T30 bit, then remove the airbag assembly.

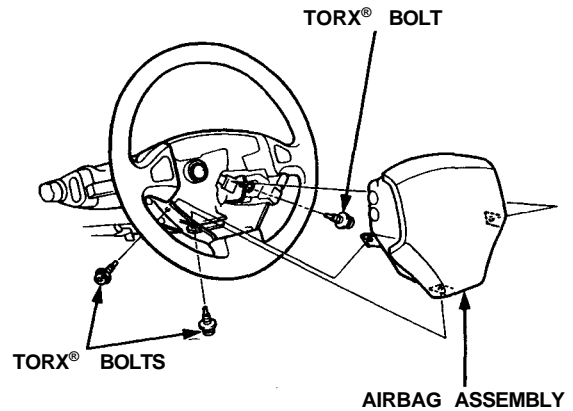
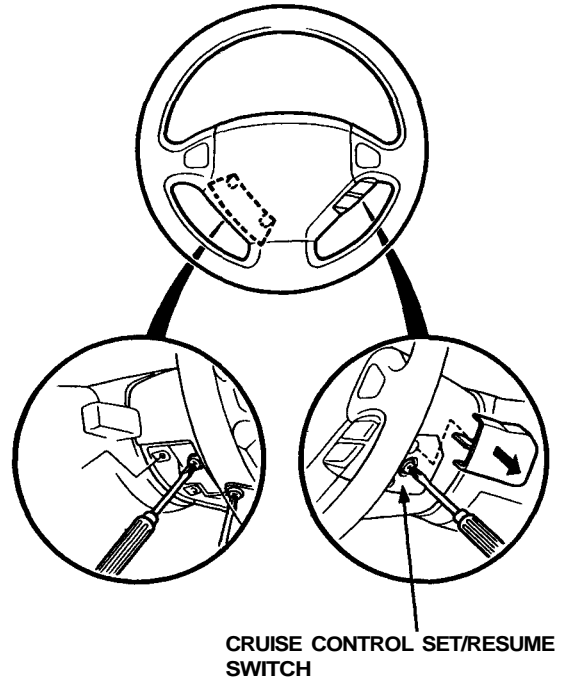

(cont'd)



Removal (cont'd)

- Disconnect the connectors from the horn and cruise control set/resume switches remove the airbag connector from its dips.

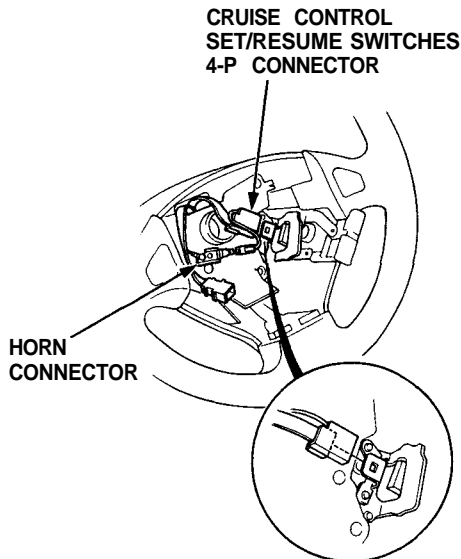

- Remove the steering wheel nut.
- Remove the steering wheel by rocking it slightly from side-to-side as you pull steadily with both hands.

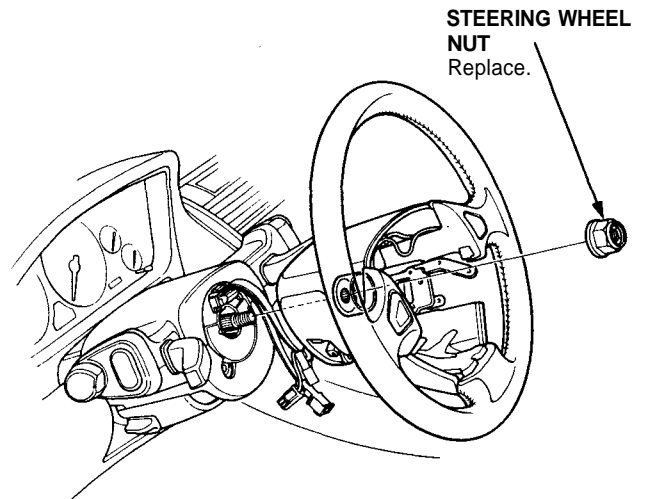

Disassembly/Reassembly

WARNING Store a removed airbag assembly with the pad surface up. If the airbag is improperly stored face down, accidental deployment could propel the unit with enough force to cause serious injury.

NOTE: If an intact airbag assembly has been removed from a scrapped car or has been found defective or damaged during transit, storage or service, it should be deployed (see [section 23](#)).

CAUTION:

- Carefully inspect the airbag assembly before installing. Do not install an airbag assembly that shows signs of being dropped or improperly handled, such as dents, cracks or deformation.
- Always keep the short connector on the airbag connector when the harness is disconnected.
- Do not disassemble or tamper with the airbag assembly.

