

Steering Column

Removal

CAUTION:

- All SRS electrical wiring harnesses are covered with yellow outer insulation.
- Before disconnecting any part of the SRS wire harness, install the short connectors (see pages 24-10('93-'96), 23-323('91-'92) and 24-11('93-'96), 23-323('91-'92)).
- Replace the entire effected SRS harness assembly if it has an open circuit or damaged wiring.

1. Disconnect both the negative cable and positive cable from the battery.
2. Remove the airbag assembly and steering wheel from the column (see page 17-8).
3. Remove the dashboard lower panel, knee bolster pad, and knee bolster.

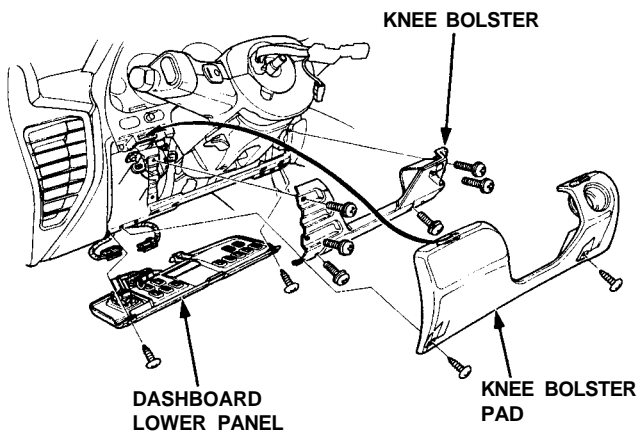

4. Disconnect the connector between the cable reel and the SRS main harness, then remove the connector holder.
5. Remove the column lower panel.

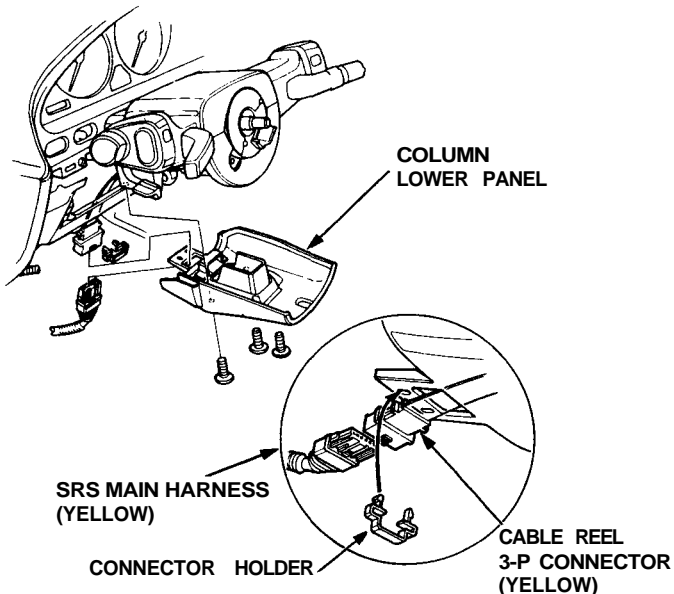

6. Remove the column covers.
NOTE: Be careful not to damage the column covers.

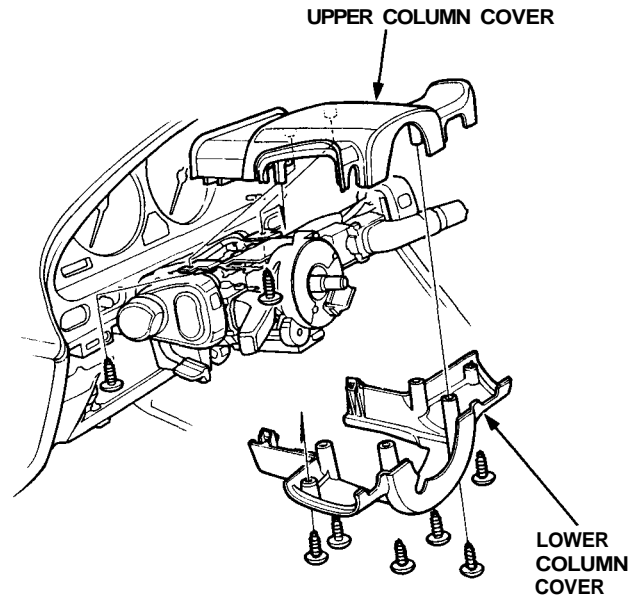

7. Disconnect the TCS sensor connector.

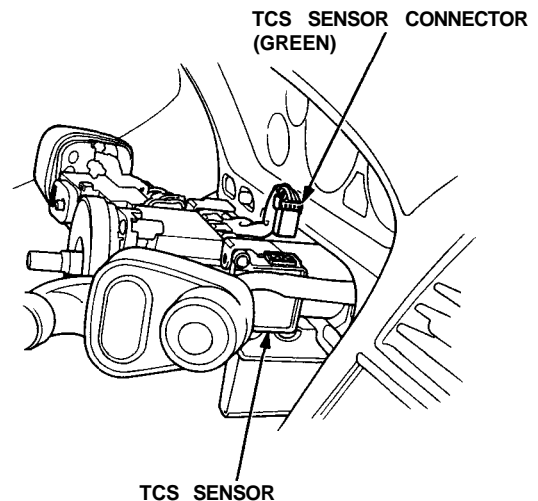



8. Remove the combination switch assembly from the column shaft.
NOTE: The combination switch can be removed by disconnecting only the TCS sensor connector.

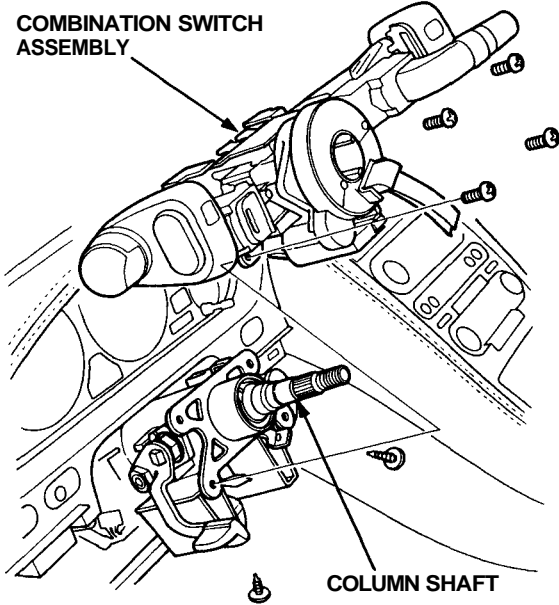

9. Remove the steering joint cover.

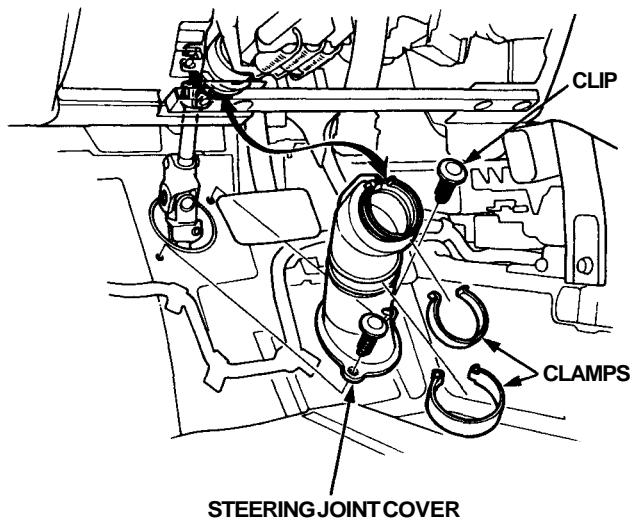

10. Remove the steering joint bolts and toothed lock washers from the steering joint.

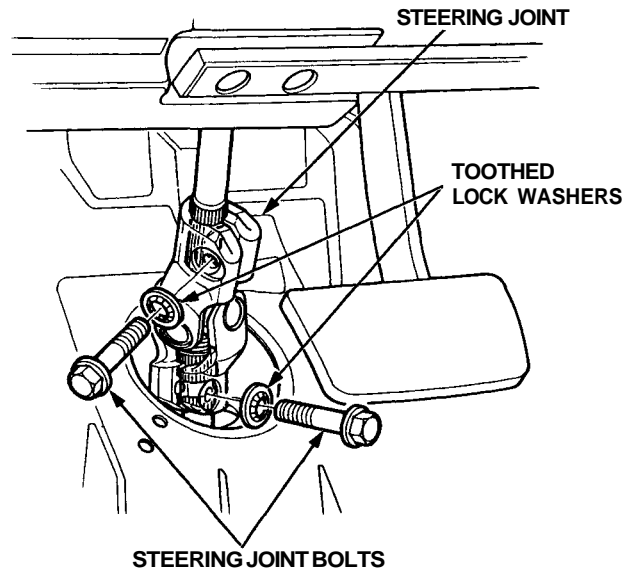

11. Disconnect the ignition switch connectors and remove the column holder, then remove the steering column assembly by removing the 8 mm bolts and flange nuts.

