



Installation

CAUTION:

- All SRS wiring harnesses are covered with yellow outer insulation.
- Replace the entire affected SRS harness assembly if it has an open circuit or damaged wiring.

1. Slip the lower end of the steering joint onto the pinion shaft.
2. Reposition the column assembly on the hanger bracket and loosely tighten with 8 mm flange nuts.

COLUMN ASSEMBLY

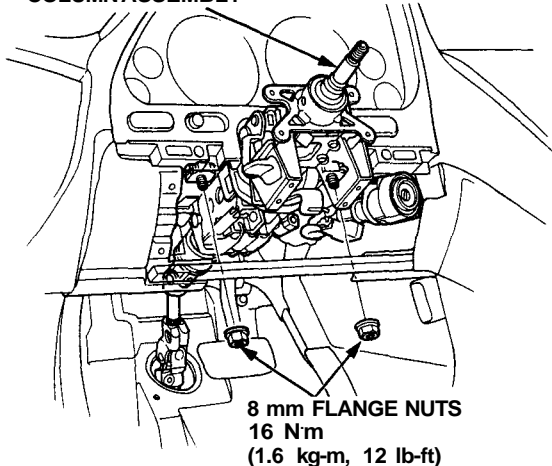

8 mm FLANGE NUTS
16 N·m
(1.6 kg-m, 12 lb-ft)

3. Tighten to the steering joint bolts.

NOTE:

- Be sure that the lower bolt is securely in the groove in the steering gearbox pinion shaft.
- Be sure the pinion shaft and the steering column shaft are aligned; the joint should slip on freely. If not reposition the steering rack to correct the misalignment.

STEERING JOINT

Slip the upper end of the steering joint onto the steering shaft (line up the bolt hole with the groove around the shaft) and loosely install the upper bolt.

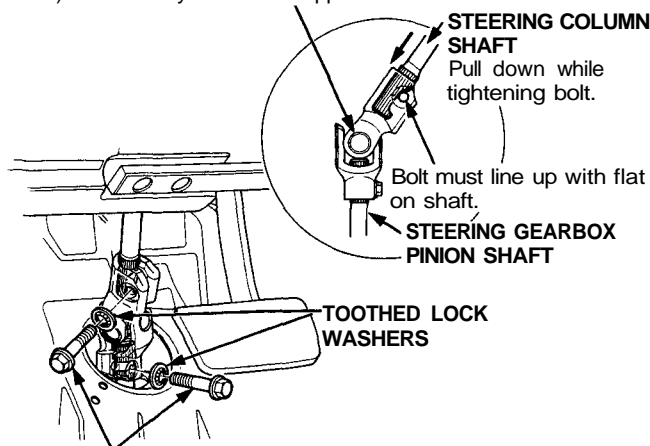

STEERING COLUMN SHAFT
Pull down while tightening bolt.

Bolt must line up with flat on shaft.
STEERING GEARBOX PINION SHAFT

TOOTHED LOCK WASHERS

STEERING JOINT BOLTS
22 N·m (2.2 kg-m, 16 lb-ft)

4. Install the column holder with the 8 mm bolts.

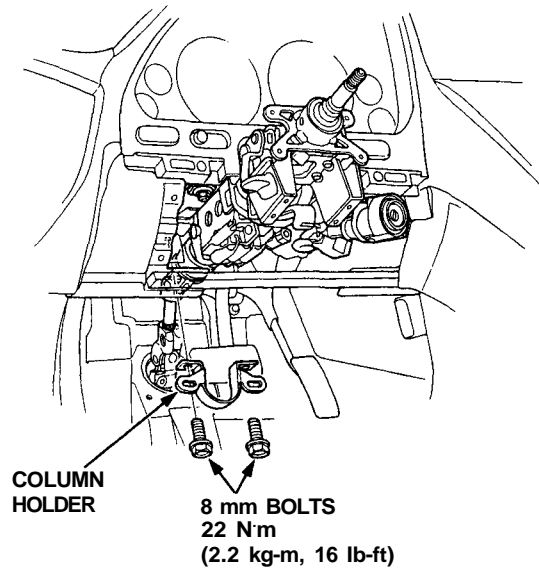

COLUMN HOLDER

8 mm BOLTS
22 N·m
(2.2 kg-m, 16 lb-ft)

5. Tighten the 8 mm flange nuts to the specified torque.
6. Install the steering joint cover with the clamps and clips.

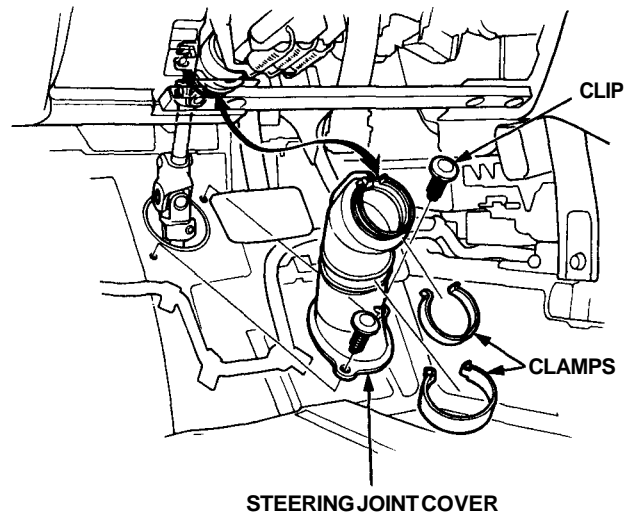

CLIP

CLAMPS

STEERING JOINT COVER

(cont'd)

Steering Column

Installation (Cont'd)

7. Install the combination switch assembly into the column shaft.

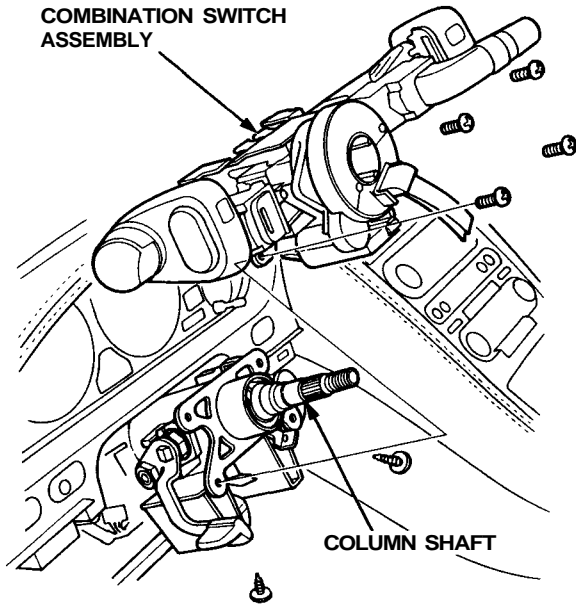

8. Reconnect TCS sensor connector.

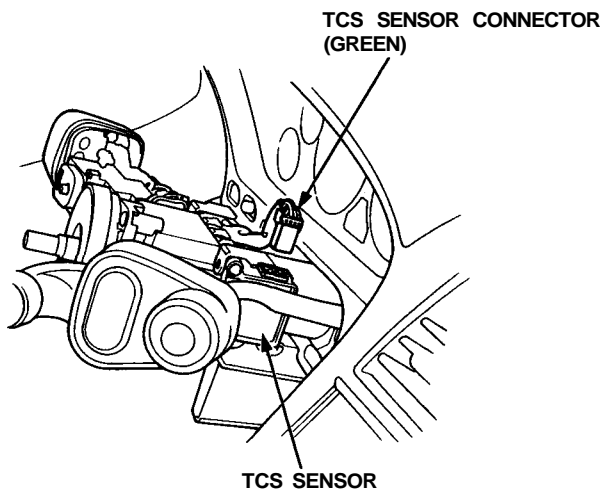

9. Install the column covers.
NOTE: Be careful not to damage the column covers.

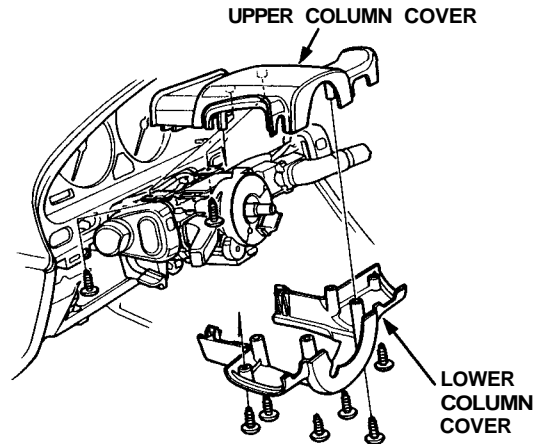

10. Insert the cable reel 3-P connector through the column lower panel and attach it to the column lower panel with the connector holder. Then connect the SRS main harness and cable reel 3-P connector.

11. Install the column lower panel.

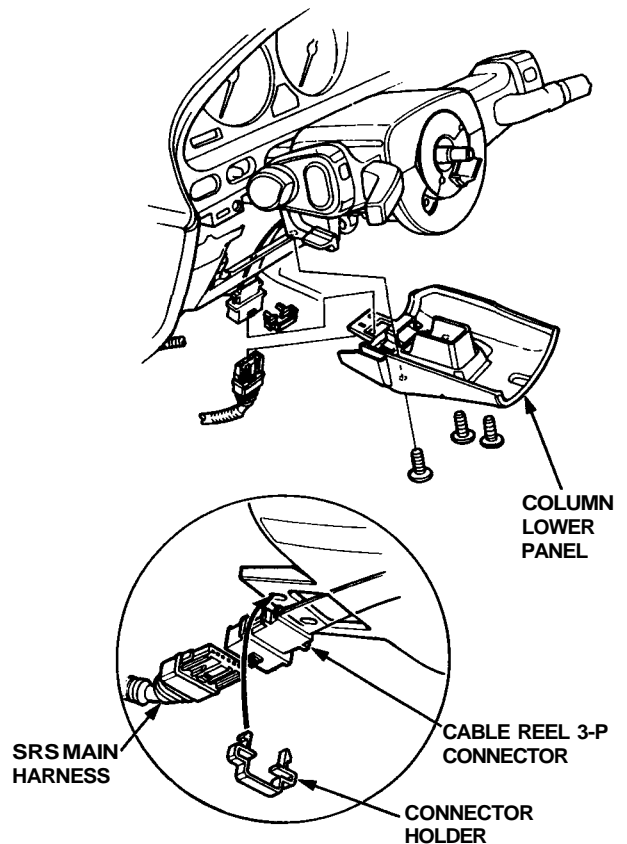



12. Install the knee bolster and pad.
13. Connect the foot well light harness and light-on warning chime to the dashboard lower panel, then install the dashboard lower panel.

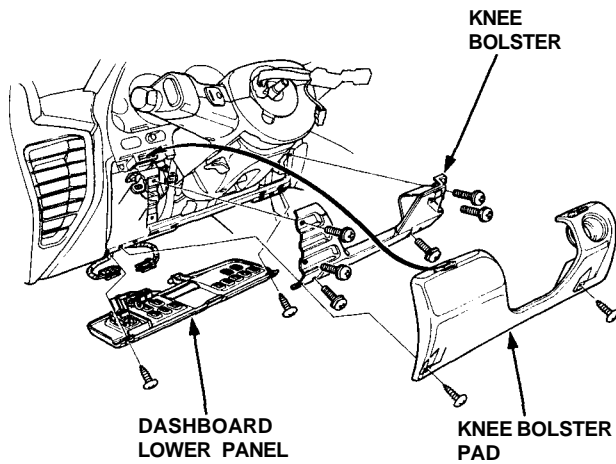

14. Install the steering wheel and airbag assembly to the column (see page [17-10](#)).