

System Description

Function and Operation

Steering Sensor

The steering sensor consists of a torque sensor, an interface, and the rotation sensor.

Torque Sensor

The torque sensor converts steering torque input and its direction to voltage signals, in conjunction with the interface.

A torsional force caused by steering operation is converted to an axial movement of a slider core. A variable differential transformer is installed around the slider core. Within the transformer are three coils, primary coil on the inside, and two secondary coils, one for right turns and one for left turns.

Alternating current is passed through the primary coil when the system is energized. The amount of mutual induction from the primary coil to the secondary coils changes depending on the position of the slider coil. The input shaft and the slider are one piece. Rotation of the shaft moves the slider in a circular direction. The pinion is turned via the torsion bar. The slider core is installed on the pinion shaft on grooves, and turns with the pinion shaft.

When there is little resistance, the input shaft torsion bar, pinion shaft, and the slider core turn together to the same angle. The slider core does not move up/down.

When there is resistance on the input shaft (hard to steer situation), and the slider pin is turned at an angle by the steering wheel, the torsion bar is twisted due to the resistance. Accordingly, the pinion shaft turns at a smaller angle. The difference in the turning angles changes the position of the slider pin in the groove, forcing the slider core upward or downward, depending on the direction of the turn.

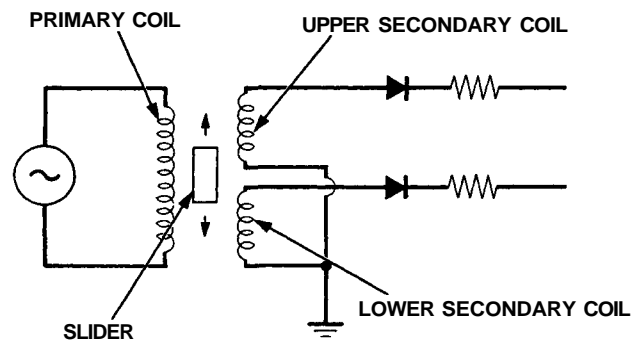
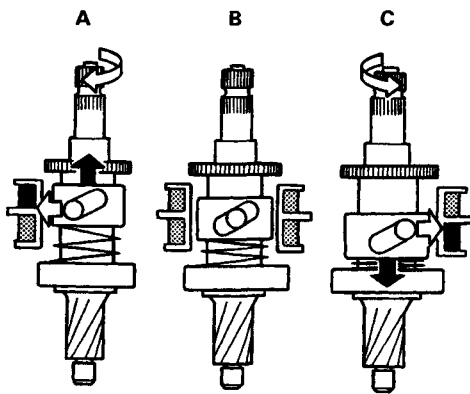
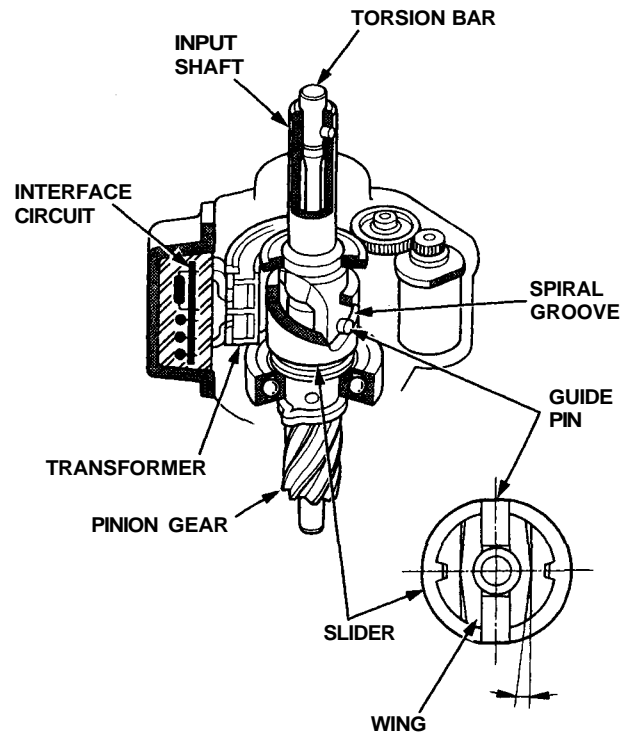

DWG No.	Steering condition	Slider movement	Induction voltage on secondary coil
A	Steering to right (load steering)	Upward shift	Voltage on upper coil increases and that on the lower decreases
B	Advancing straight ahead (no load steering)	Neutral	Voltage on upper and lower coils are equal
C	Steering to left (load steering)	Downward shift	Voltage on lower coil increases and that on the upper decreases



Rotation Sensor

The rotation sensor is housed inside the steering gearbox near the pinion. It converts the rotation speed and direction of steering into voltage signals. The rotation of the steering wheel is transmitted to the pinion, which drives the sensor by accelerating its speed through the three pieces of transmission the gears. Acting as a kind of direct current generator, the sensor generates direct current voltage proportionately with the rotational speed of the pinion. When the steering direction is reversed, the voltage is generated in the opposite direction. No power is generated when driving straight ahead without turning the steering wheel.

Interface Circuit

The interface circuit is housed inside the steering gearbox near the pinion. It rectifies and amplifies the signals from the torque sensor and the rotation sensor and transmits steering signals to the EPS control unit. A phase compensating circuit is also built in, which changes the output signals in accordance with the drive signals input from the EPS control unit.

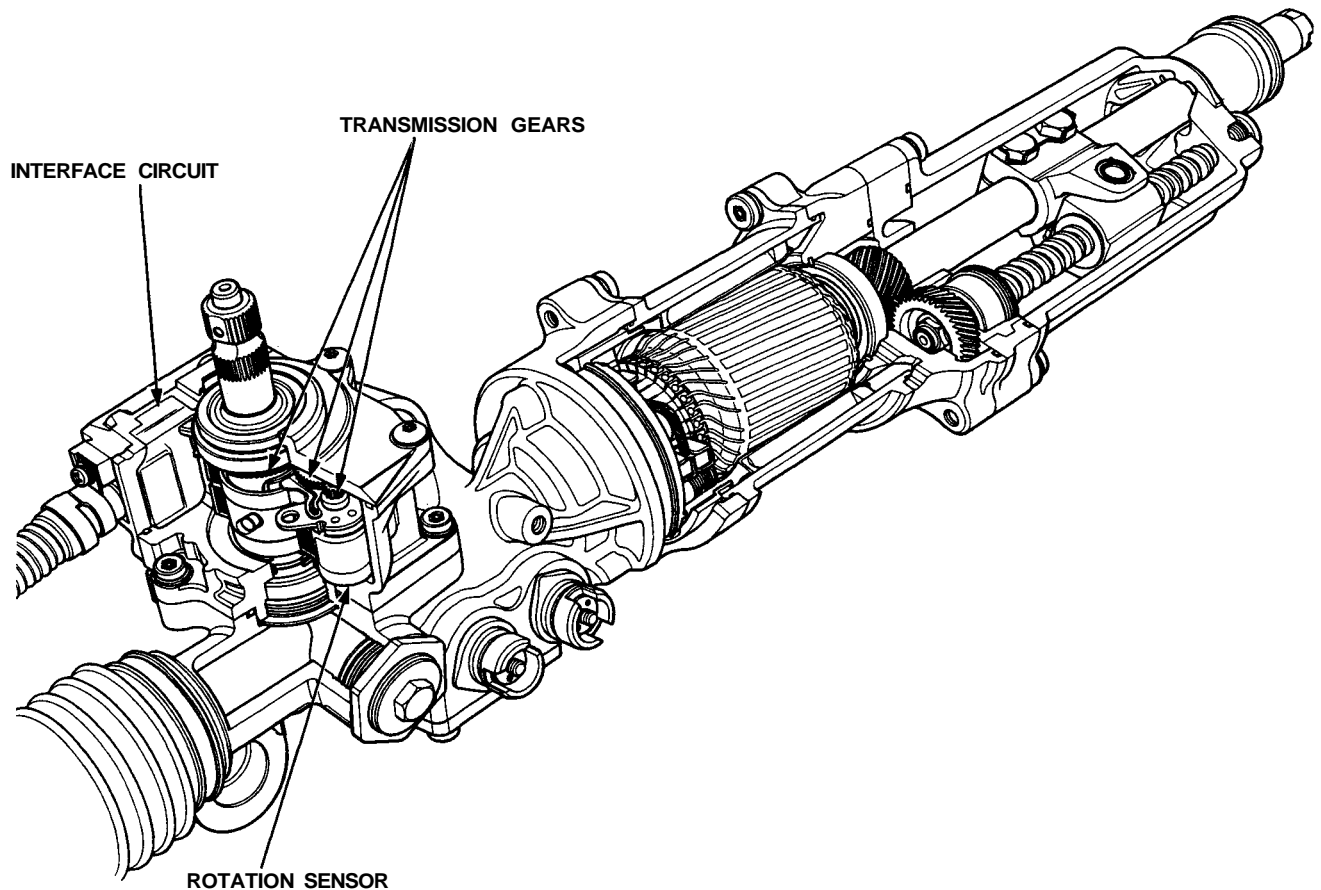

System Description

EPS Control Unit

The control unit receives input signals from the car's speed sensors, torque sensor and steering rotation sensor, and outputs control signals to the power unit. It performs a multitude of control works including a circuit which diagnoses troubles in each functional part of the system and the control unit itself. The control unit operates the system while the engine is in the process of starting, on receipt of voltage generated by the alternator. The system remains operational if the engine stalls with the ignition switch in ON position.

< Basic Control >

- (1) Travelling speeds are compiled into data, receiving input signals from the car's speed sensors.
- (2) The magnitude and direction of torque are compiled into data, receiving input signals from the torque sensor.
- (3) The rotational speed and direction of steering are compiled into data, receiving input signals from the steering rotation sensor.
- (4) Determination of motor torque data from the prescribed assisting force map, based on the car speed data, steering rotational speed data and the steering torque data.
- (5) Changeover of control modes and output of control signals to the power unit, based on data on car speed, direction of torque and rotational direction of steering.

Normal Control Mode:

The rotational direction of motor is determined after changing over to the left/right steering mode in accordance with torque direction data. The mode is switched to the straight ahead mode when the output data is zero.

Return Control Mode:

According to torque direction data and steering rotational direction data, the mode is changed over to the return control mode to improve the steering return characteristic.

Damper Control Mode:

According to car speed data, torque value data and steering rotational speed data, the mode is changed over to the damper control mode to improve the convergence property of the steering.

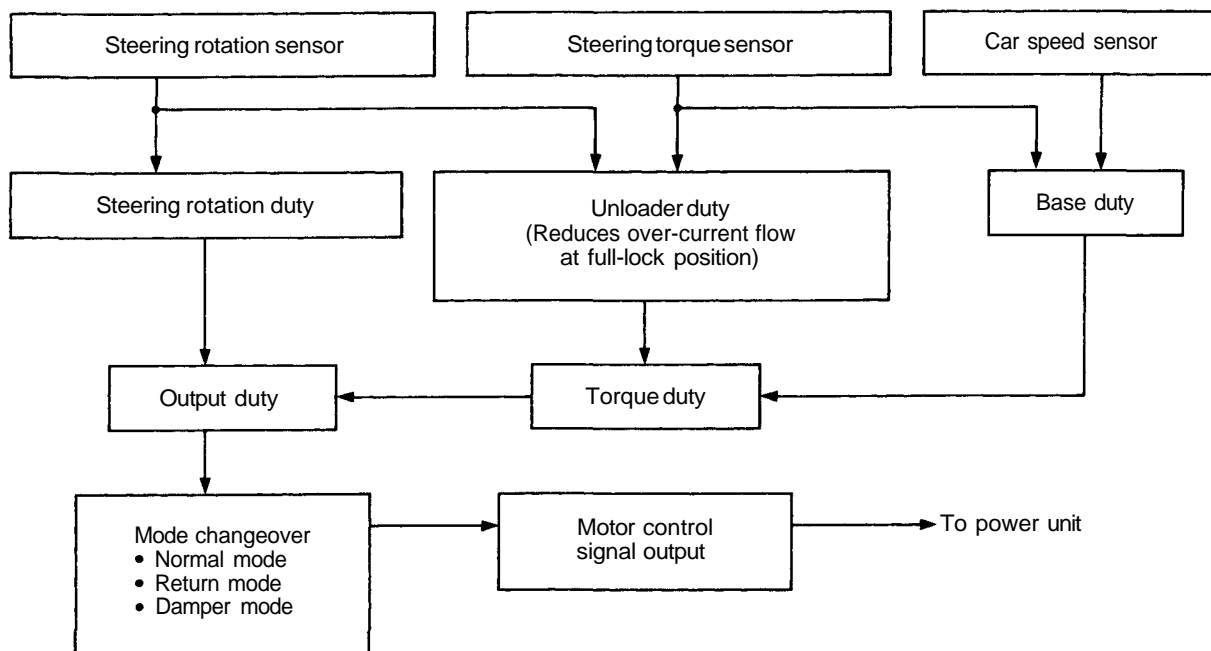

**Self-Diagnosis Function**

The EPS control unit monitors the system inputs and outputs, and the driving current of the motor. If there is a problem in the system, the control unit turns the system off by actuating the relay in the power unit. Power assist stops and normal manual steering operation resumes. The control unit also turns the EPS indicator light on to alert the driver, and memorizes the problem in the form of a code. Connecting the terminals of the service check connector with a jumper wire enables the EPS indicator light to blink the problem code when the ignition switch is turned on.

Unloader Control

If the steering wheel is turned fully and held in the full-lock position, the steering torque reaches the maximum point, and an over-current flows to the motor and the power unit. The control unit detects this and reduces the current flow to the motor.

Average Moving Current Control

The electric current flow to the motor is estimated from the current values detected by the current sensor, and the average current is obtained at two second intervals. The motor driving current is suppressed when the average current value exceeds a predetermined marginal value. The control unit regulates the motor current during continuous loading to suppress any excessive temperature rise in the power unit and the motor.

Over-Voltage Control

If there is an excessive increase in power source voltage due to a poor battery condition, an alternator voltage regulator problem, etc., the motor assisting force increases, resulting in excessive control. To prevent this, the control unit signals to the power unit are corrected to ensure that adequate assisting force is generated.

System Description

Power Unit

The power unit consists of a driving circuit, current sensor, field effect transistor (FET) bridge circuit, and two relays. It receives control signals from the CPU and controls the driving current of the motor. The driving circuit controls the rotational direction and speed of the motor by driving the FET bridge circuit with a pulse width modulation (PWM) method on receipt of an input of driving signals from the EPS control unit.

< Rotational Speed Control >

The PWM driving signal is a digital signal repeating the process of voltage ON/OFF at a constant frequency, which changes the ratio of ON time per one cycle of this signal. The ratio is called the duty ratio. When there is a change in duty ratio, the average voltage changes as smoothly as an analog type. The ratio of digital signal voltage (E) and the average voltage (V) is called the duty ratio (δ). Its relationship is expressed by $V = E \times \delta$. When the duty ratio is low, the rotational speed of motor is slow. As the duty ratio increases, the rotational speed increases to increase the torque.

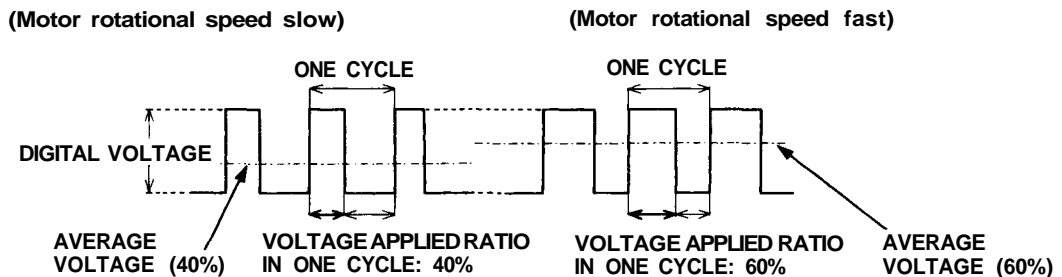

< Rotational Direction Control >

Normal Mode Control:

The table below shows the normal control mode to control the flow of current from the battery:

Steering condition	FET (1)	FET (2)	FET (3)	FET (4)	Motor operation
Steering to right	ON	OFF	OFF	PWM	Operates in direction steering to the right
Straight ahead	OFF	OFF	OFF	OFF	Stops
Steering to left	OFF	ON	PWM	OFF	Operates in direction steering to the left

("PWM" in the table indicates PWM control based on torque sensor data).

Return Control Mode:

Return control mode improves the steering return characteristics. ("PWM" in the table denotes PWM control based on torque sensor data while "PWM-r" PWM control based on rotation sensor).

Damper Control Mode:

The damper mode control which improves the convergence of steering, is performed with damper mode signals from the control unit. In this mode, a short current circuit is formed on the motor side by turning off FET (1) and (2), and on FET (3) and (4), which suppresses the returning speed of the steering.

< Motor Driving Current Control >

A current sensor, power relay and fail-safe relay are built into the power unit. The current sensor detects motor driving current and transmits data to the EPS control unit. If there is a problem in the system, a cut-off signal is sent from the EPS control unit to relay, then the relay cuts off motor current to switch to manual steering operation.

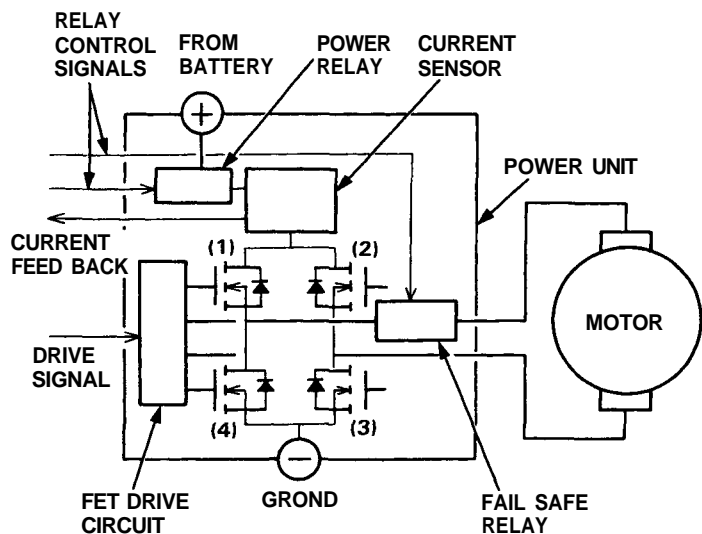

Steering condition	FET (1)	FET (2)	FET (3)	FET (4)
Return from right steering to straight ahead	PWM-r	OFF	OFF	PWM
Return from left steering to straight ahead	OFF	PWM-r	PWM	OFF



Steering Gearbox

< Motor and Power Assist Mechanism >

A motor is housed inside the gearbox housing. It consists of a yoke with a permanent magnet fixed in it, a rotor with a field coil, and brushes which pass electricity to rotor commutators. The motor is on the rack shaft of the steering gearbox. The drive current from the power unit flows through the power relay and fail-safe relay to the brushes of the motor. The drive current flows to rotor commutators through brushes, exciting the field coil of the rotor and rotates the rotor with the magnetic action of the permanent magnet inside the yoke. The rotor rotates in the opposite direction when the direction of drive current is reversed.

The rotation torque of the motor is transmitted to the ball screw through the helical gear. The rotation torque on the ball screw is converted into assist thrust in the direction of steering rack by the recirculating ball screw. The recirculating ball screw acts to reduce the steering thrust put into the steering rack through the joint to lessen the steering force required at the steering wheel.

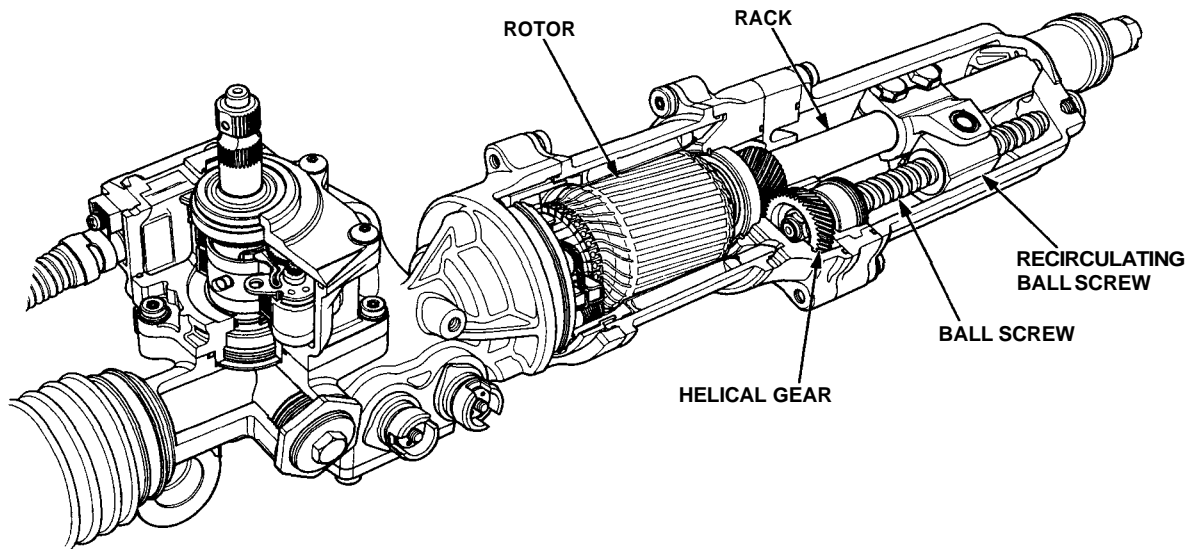

< Recirculating Ball Screw >

The recirculating ball screw is constructed so that balls roll between the screw shaft and the nut, and those coming out of the screw face enter the screw groove again through a tube for recirculation. The rotation torque on the shaft is converted into thrust in axial direction as the slope of the screw shaft presses against the nut through balls. Since the torque conversion is made in this method through the screw shaft and balls, the friction is small, high transmission efficiency is obtained for both the forward and backward directions, and the steering feels identical to the ordinary manual steering. Furthermore, since the force from the backward direction (force pressing the steering rack) is converted into the rotation, torque of the screw shaft, instantaneous kick-back from road surface will rapidly rotate the motor. In such a rapid rotation, the inertia of the motor increases, which acts to reduce the kick-back. Any great kick-back will be transmitted from the steering rack to the torque sensor on the pinion, which acts to twist the pinion shaft in the same direction as the input direction of kick-back. As a result, the motor operates the kick-back to reduce assist force.

