

# Power Steering

## Gearbox Removal/Installation

NOTE: Before removing the steering gearbox, make sure the front wheels are straight ahead.

1. Remove the steering joint cover.

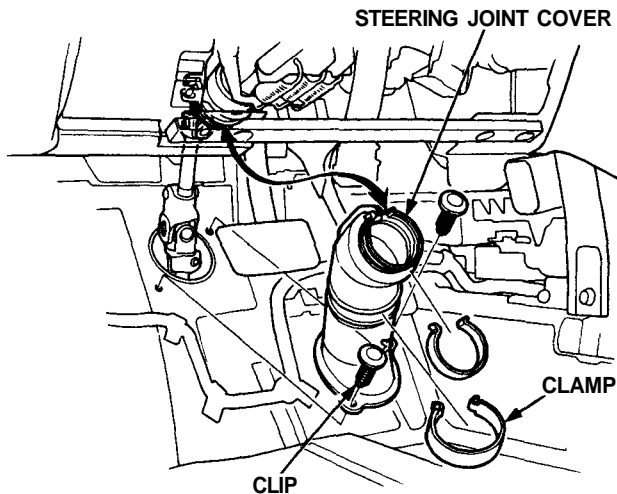

2. Remove the steering joint bolts, and disconnect the steering joint by moving the joint toward the column.

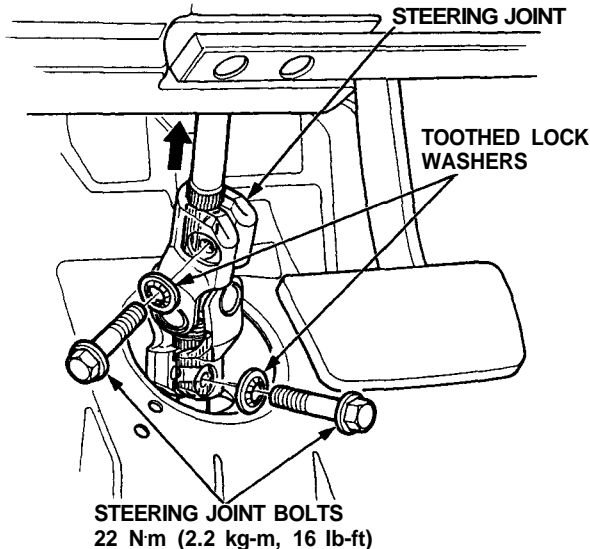

3. Lock the steering shaft with ignition key to keep the steering shaft position.
4. Raise the car and place safety stands in the proper locations (see section 1).
5. Remove the front wheels.
6. Remove the cotter pin from the castel nut and remove the nut.

7. Install the 10 mm hex nut on the ball joint. Be sure that the 10 mm hex nut is flush with the ball joint pin end, or the threaded section of the ball joint pin might be damaged by the ball joint remover.

NOTE: Remove the ball joint using the Ball Joint Remover, 28 mm (07MAC-SL00200). Refer to page 18-21 for how to use the ball joint remover.

8. Separate the tie-rod ball joint and knuckle using the special tool.

CAUTION: Avoid damaging the ball joint boot.

NOTE: If necessary, apply penetrating type lubricant to loosen the ball joint.

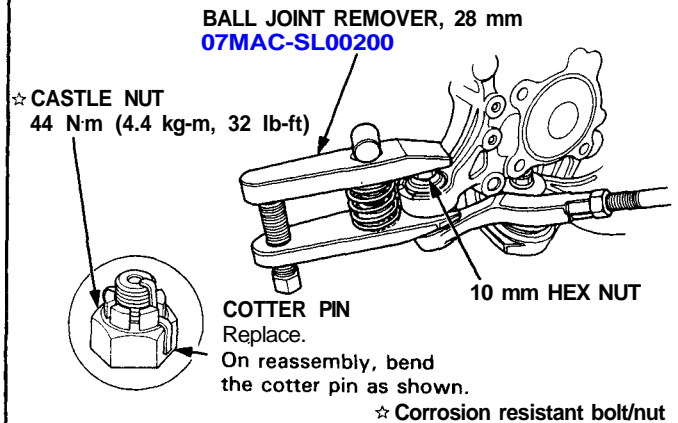

9. Remove the folding spare tire and spare tire holder plate.

10. Disconnect the battery negative terminal, then disconnect the positive terminal and remove the battery.

11. Remove the spare tire holder and floor under cover.

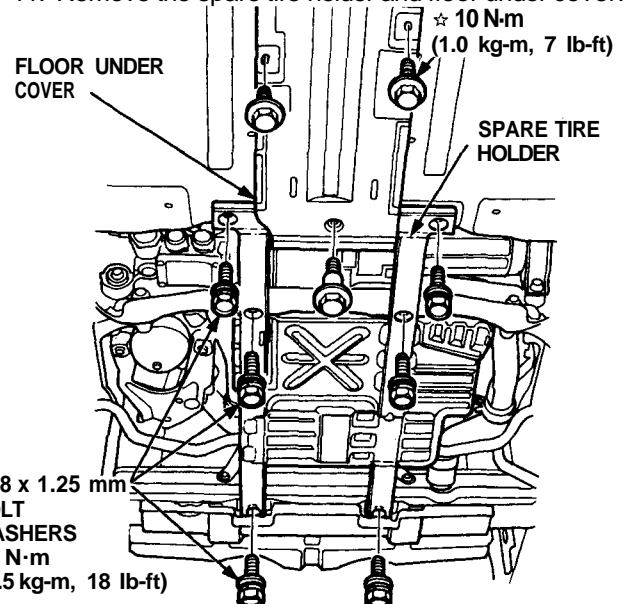

☆ Corrosion resistant bolt/nut



12. Disconnect the connectors from the EPS wire harness.
13. Remove the ground cable by removing the EPS wire harness stay.

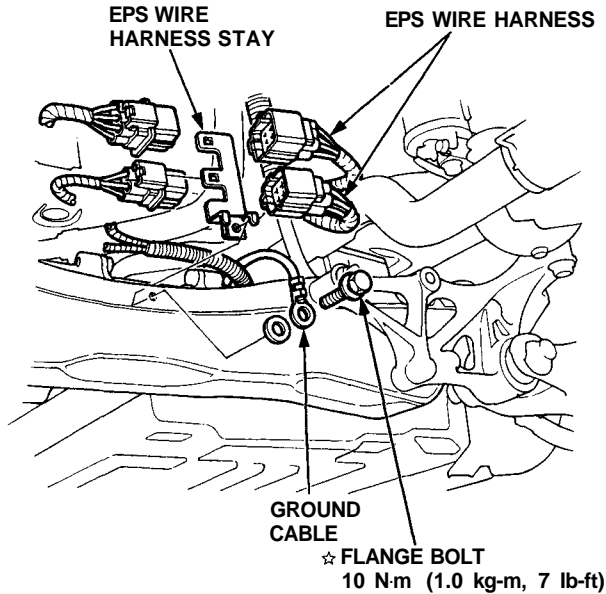

14. Remove the terminal guard and ground cable.
15. Remove the terminal nuts and the wires from the gearbox terminals.

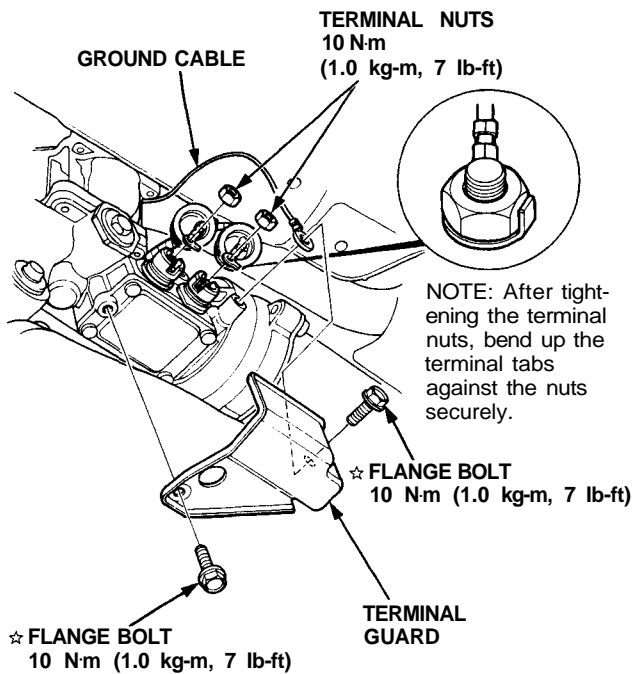

☆ Corrosion resistant bolt

16. Remove the radiator pipe bracket at the front compartment bulkhead.

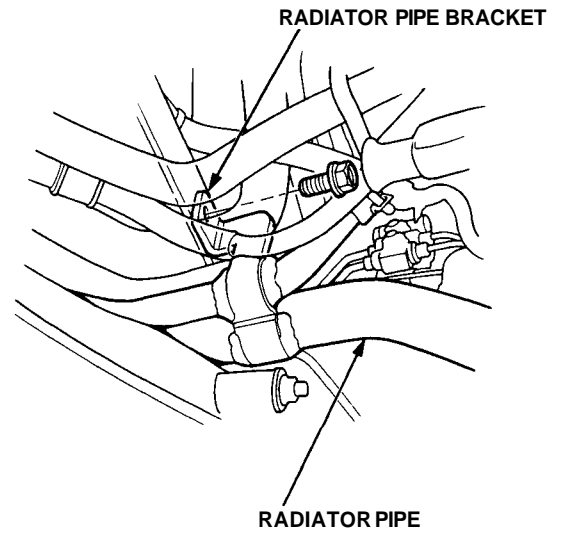

17. Remove the radiator pipe bracket at the floor, and space the radiator pipe away from and gearbox.

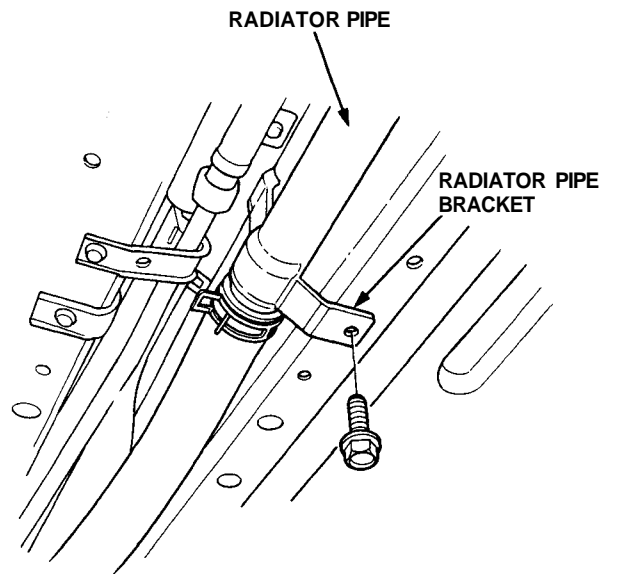

(cont'd)

# Power Steering

## Gearbox Removal/Installation (cont'd)

NOTE: Before removing the gearbox, place a stand jack under the gearbox and front crossbeam to lightly support them. Lower the gearbox together with the front crossbeam.

18. Remove the flange bolts and nuts of the gearbox and front crossbeam.

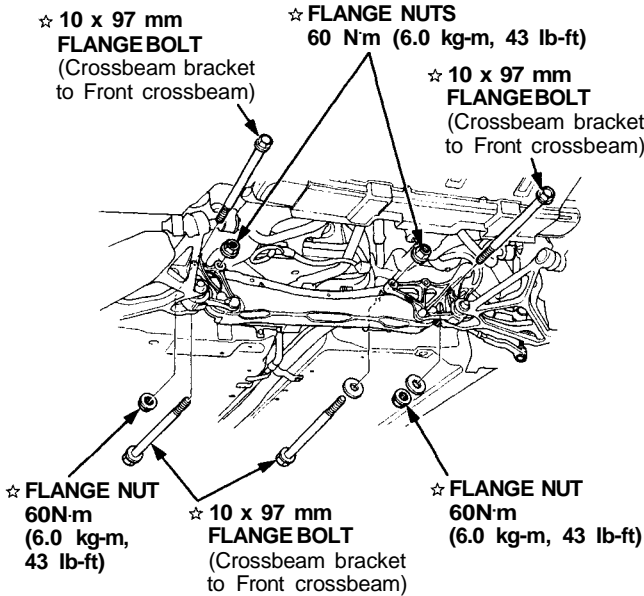

LEFT SIDE:

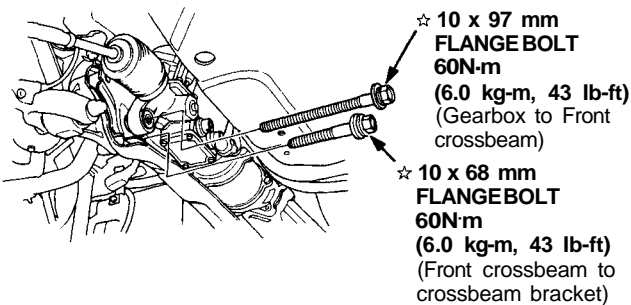

RIGHT SIDE:

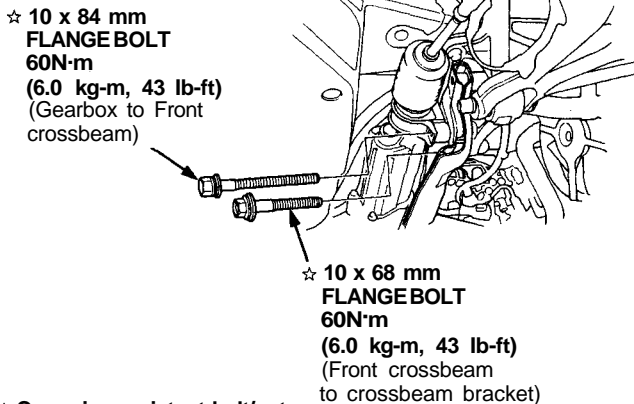

☆ Corrosion resistant bolt/nut

19. Lower the gearbox and front crossbeam with care so as not to interfere with the radiator pipe.

NOTE: The crossbeam is attached to the crossbeam bracket with knock pins. Remove the crossbeam by lightly taping on it with a plastic hammer, then remove the gearbox.

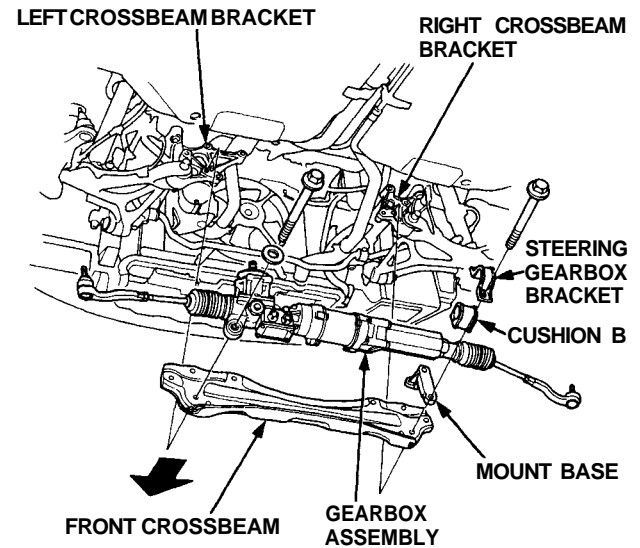

20. When installing the crossbeam to the crossbeam bracket, be sure to align the holes in the crossbeam with the knock pins on the crossbeam bracket.

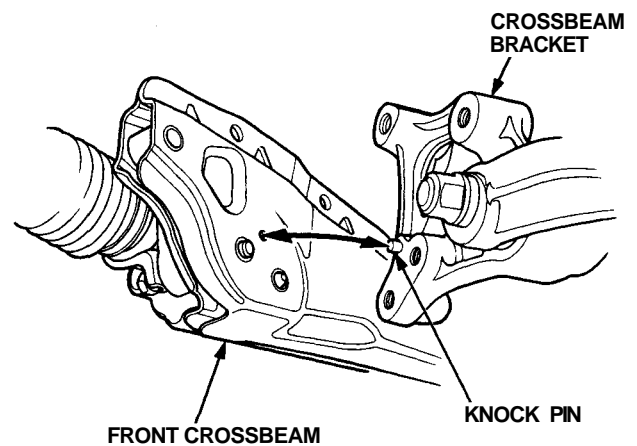



21. Install the gearbox in the reverse order of removal.

NOTE: When connecting the steering joint, make sure that the cable reel of airbag system is centered.

22. Set the steering rack in the center of its stroke.
23. Center the cable reel as follows:  
Turn the steering wheel left approx. 150 degrees, to check the cable reel position with indicator. If the cable reel is centered, the yellow gear tooth lines up with the alignment mark on the cover. Return the steering wheel right approx. 150 degrees to position the steering wheel in the straight ahead position.

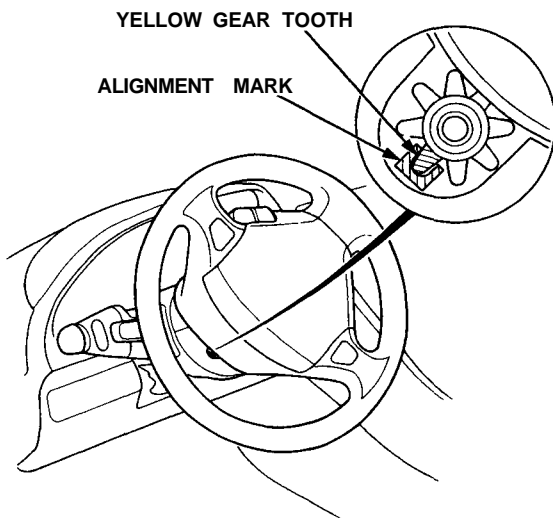

24. Slip the lower of the steering joint onto the pinion shaft (line up the bolt hole with the groove around the shaft) and loosely install the lower bolt.

NOTE:

- Be sure that the lower steering joint bolt is securely in the groove in the steering gearbox pinion.
  - If the steering wheel and rack are not aligned centered, reposition the serrations at lower side of the steering joint.
25. Adjust the front toe after install the gearbox (see [section 18](#)).