



Replacement

SRS wire harnesses are routed near the dashboard and steering column.

CAUTION:

- All SRS wiring harnesses are covered with yellow outer insulation.
- Before disconnecting any part of the SRS wire harness, install the short connectors (see page 23-328).
- Replace the entire affected SRS harness assembly if it has an open circuit or damaged wiring.

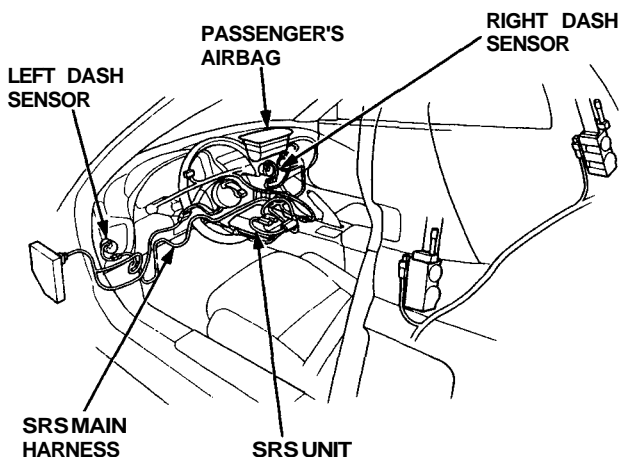

- To remove the dashboard, first remove the:
 - Seats (See page 20-39('93-'96))
 - Dashboard lower cover (Driver's) (See page 20-54))
 - Knee bolster and pad (See page 20-54)
 - Dashboard brace (See page 20-54)
 - Center armrest (See page 20-49)
 - Clock, center air vent and console panel (See pages 20-50, 51, 52)
 - Climate control unit and stereo cassette/radio (See page 20-53)
 - Dashboard lower cover (Passenger's) (See page 20-53)
 - Glove box lid and glove box (See page 20-53)
- Lower the steering column (see section 17).

⚠ WARNING To avoid accidental deployment and possible injury always install the short connector on the airbag connector when the SRS wire harness is disconnected.

NOTE:

- Remove the access panel, then remove the short connector (RED). Disconnect the connector between the airbag and cable reel, then connect the short connector (RED) to the airbag connector.

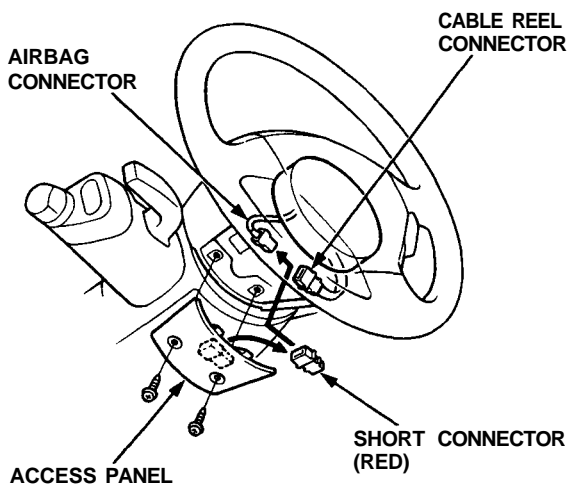

- Connect the special tool to the cable reel connector.

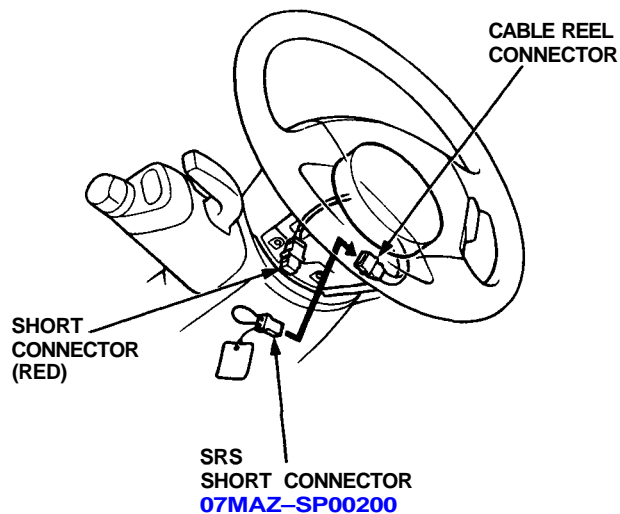

(cont'd)

Dashboard

Replacement (cont'd)

NOTE: To prevent damage to the steering column, wrap with a shop towel.

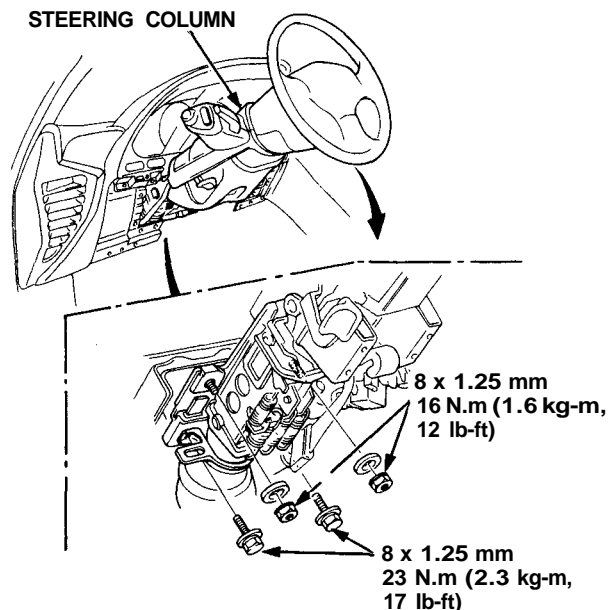

- Remove the nuts, then remove the airbag bracket (passenger's).

▲ WARNING To avoid accidental deployment and possible injury always install the short connector on the airbag connector when the SRS wire harness is disconnected.

NOTE:

- Disconnect the connector between the passenger's airbag and SRS main wire harness. Connect the short connector (RED) to the airbag connector.

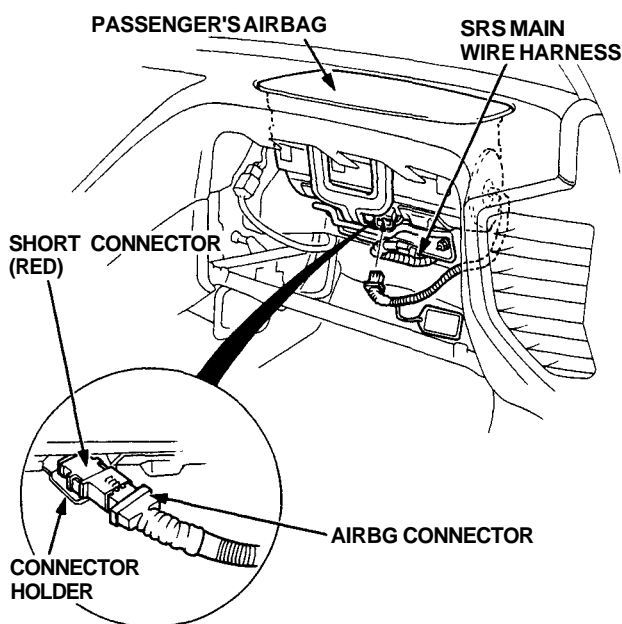

- Connect the special tool to the SRS main wire harness connector.

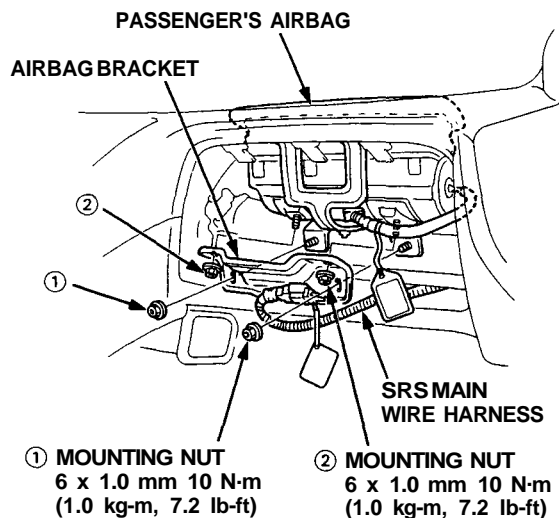
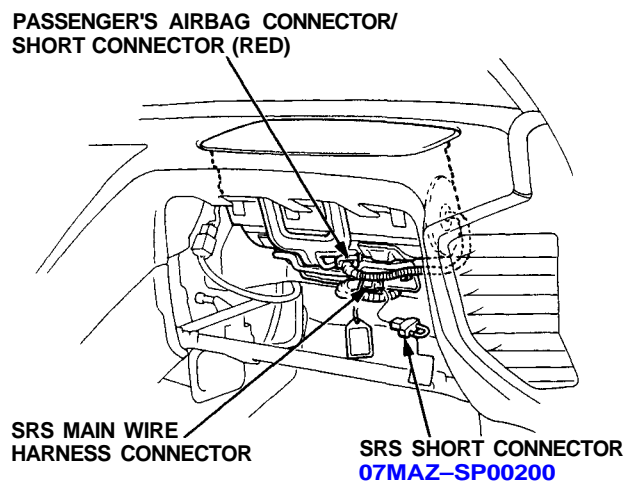

- When installing the airbag bracket, tighten the mounting nuts in the numbered sequence.

- Remove the instrument panel and gauge assembly.

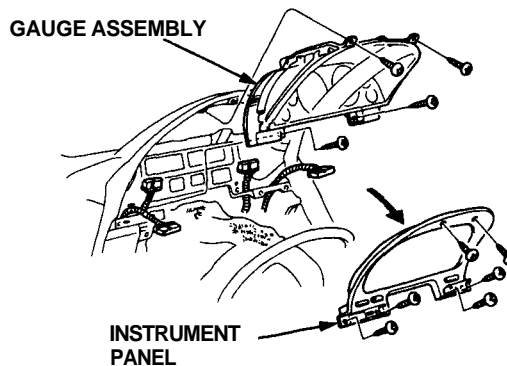



5. Remove the mounting screws, then remove the side air vents from each side of the dashboard.
6. Remove the dashboard end plate and fold the console carpet down (see page 20-47).
7. Remove the dashboard mounting bolts and screw, then lift and remove the dashboard.

NOTE:

- Take care not to scratch the dashboard.
- Use protective tape on the bottom of the front pillar trim.
- To prevent damage to the shift lever (M/T) or selector lever and indicator panel (A/T), wrap with a shop towel.

CAUTION: When prying with a flat tip screwdriver, wrap it with protective tape or a shop towel to prevent damage.

NOTE: If necessary, remove the defrost panel.

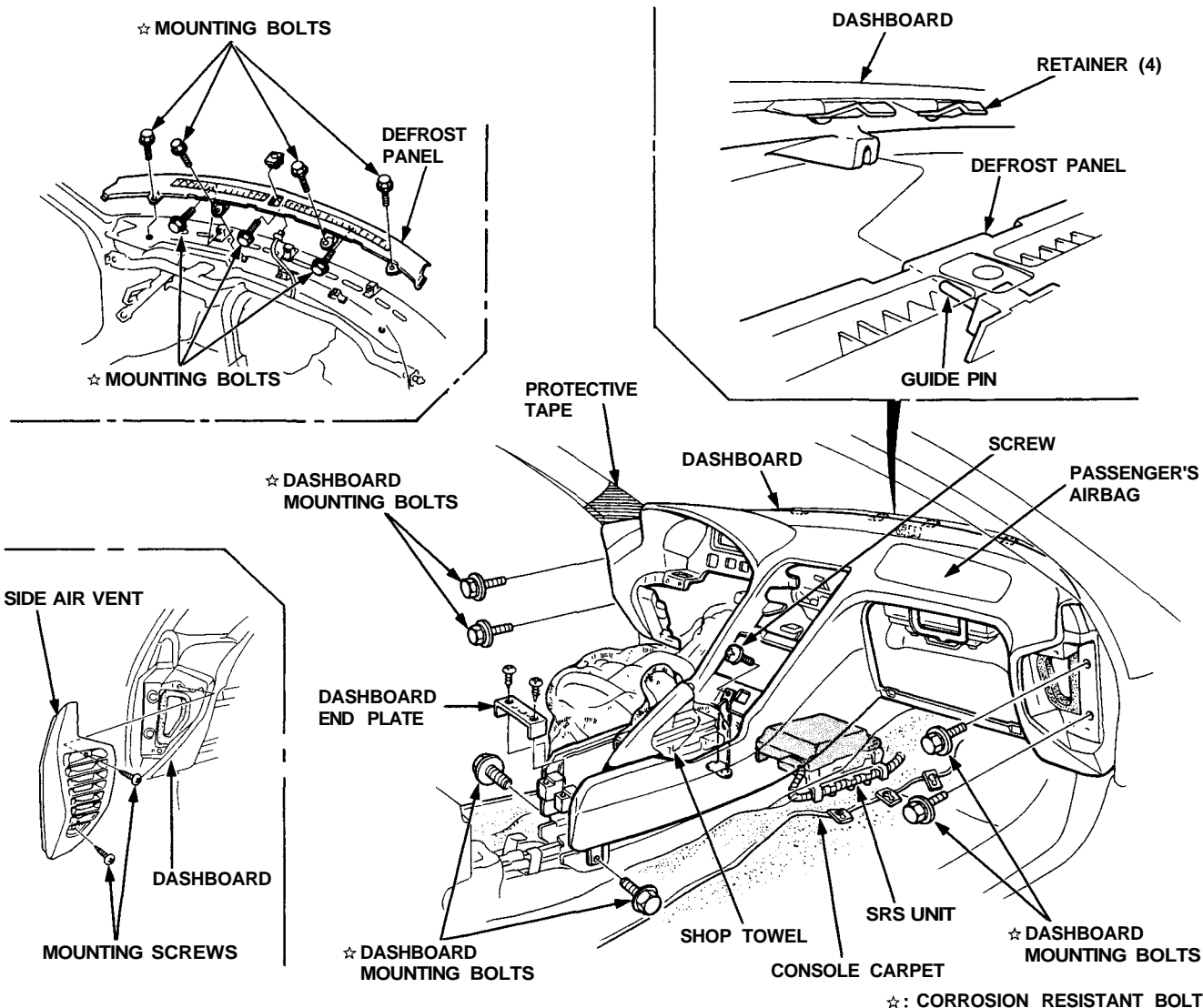

8. Installation is the reverse of the removal procedure.

NOTE:

- Make sure the dashboard fits onto the guide pin and defrost panel correctly.
- Before tightening the mounting bolts, make sure the wire harnesses are not pinched.