

# Transmission Housing

## Removal

NOTE: Place the clutch housing on two pieces of wood thick enough to keep the mainshaft from hitting the workbench.

1. Remove the back-up light switch, neutral switch and speed sensor.

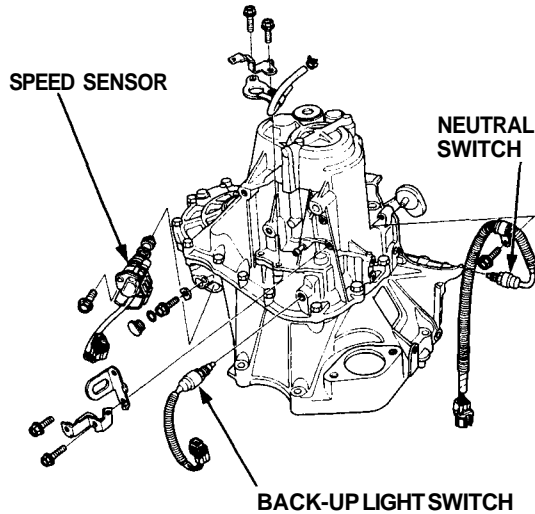

2. Remove the sealing bolts, springs and steel balls.
3. Remove the upper cover, then remove the transmission housing attaching bolts.
4. Remove the 36 mm sealing bolt.

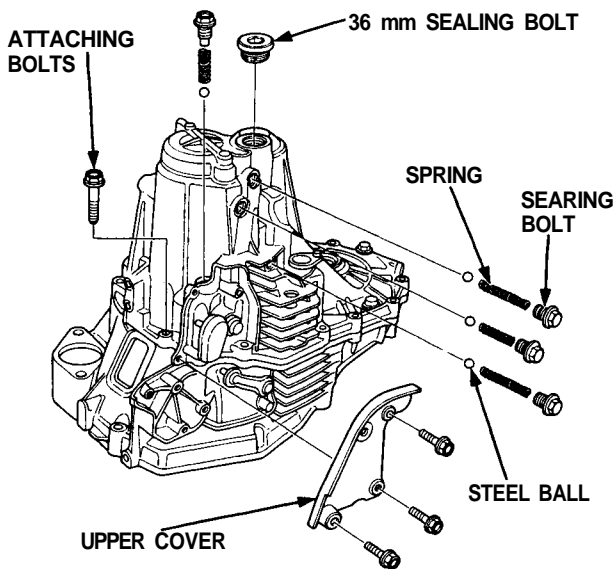

5. Expand the snap ring on the countershaft ball bearing and remove it from the groove using a pair of snap ring pliers.

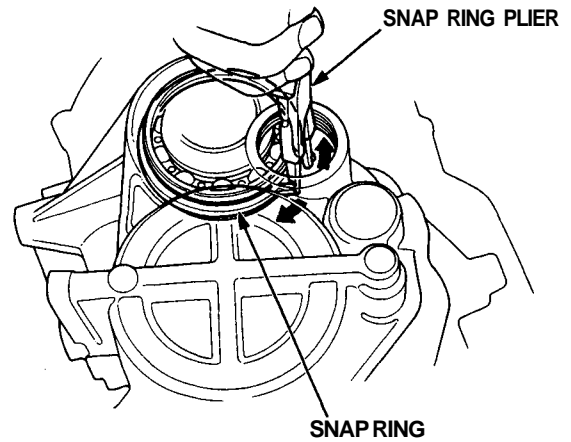

6. Separate the clutch housing from the transmission housing.
7. Remove the thrust shim and oil guide plate from the transmission housing.

