

Under-Dash Fuse Box

Removal/Installation

CAUTION;

- Be sure to install the SRS wiring so that it is not pinched or interfering with other car parts.
- Always keep the short connector on the airbag connector when the harness is disconnected.

Removal:

1. Disconnect both the negative cable and positive cable from the battery.
2. Remove the maintenance lid A below the airbag, then remove the short connector.

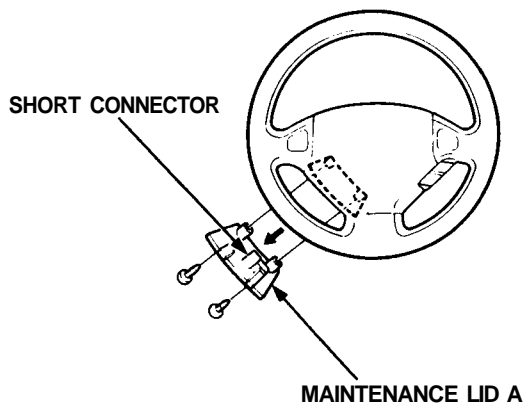

3. Disconnect the connector between the airbag and cable reel.
4. Connect the short connector to the airbag side of the connector.

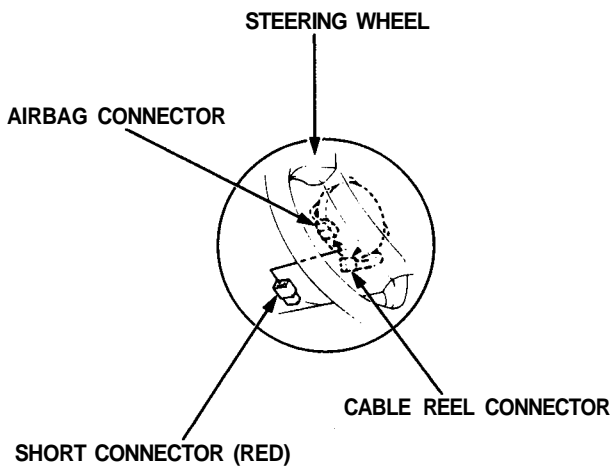

5. Remove the door sill molding.
6. Remove the kick panel trim pieces, as necessary.
7. Remove the under-dash fuse box mounting bolts.
8. Disconnect the under-dash fuse box connectors.

NOTE: The SRS main harness connector is double locked. To remove it, first lift the connector lid with a thin screwdriver, then press the connector tab down and pull the connector out.

9. Take out the under-dash fuse box.

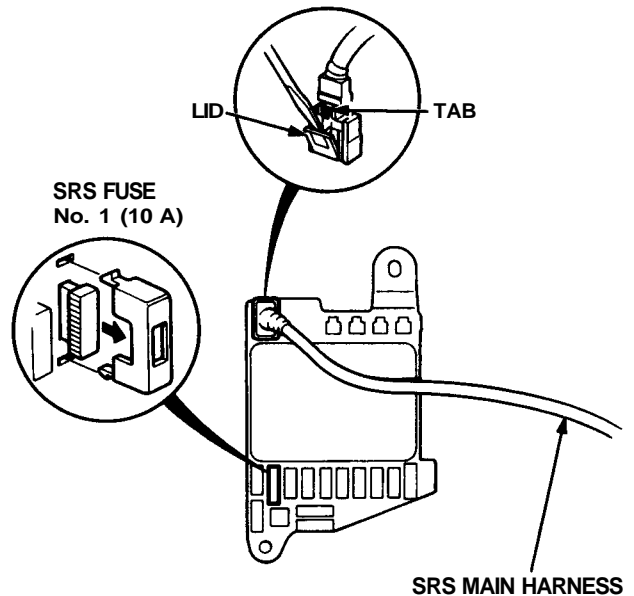
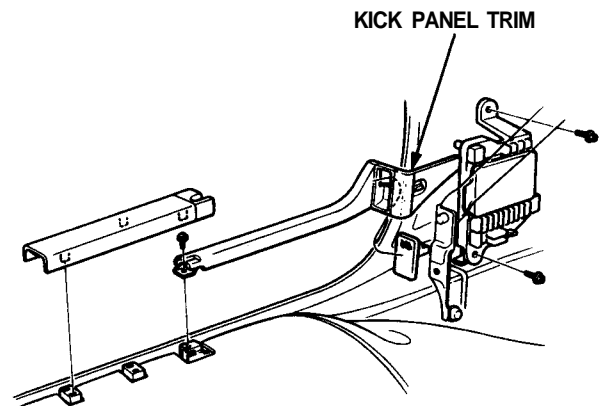



Installation:

1. Install the under-dash fuse box.

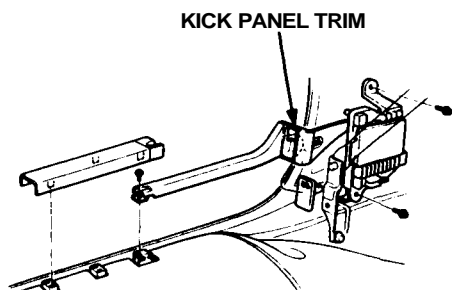

2. Connect the connectors to the under-dash fuse box.

NOTE: To reinstall the SRS main harness connector, push it into position until it clicks, then close the connector lid.

3. Install the kick panel trim pieces.
4. Disconnect the short connector from the airbag.

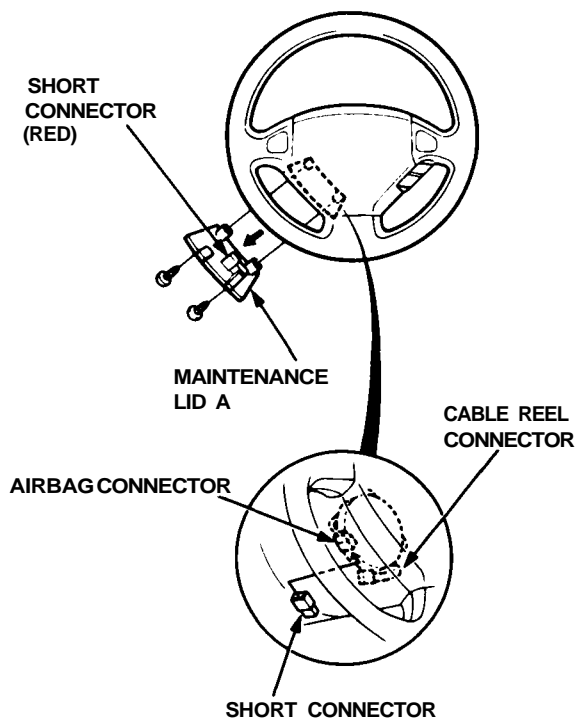

5. Connect the airbag 2-P connector and cable reel 2-P connector.
6. Attach the short connector to the lid A and attach to the steering wheel.
7. Connect both the negative cable and positive cable to the battery.
8. After installing the under-dash fuse box, confirm that all systems work properly.