

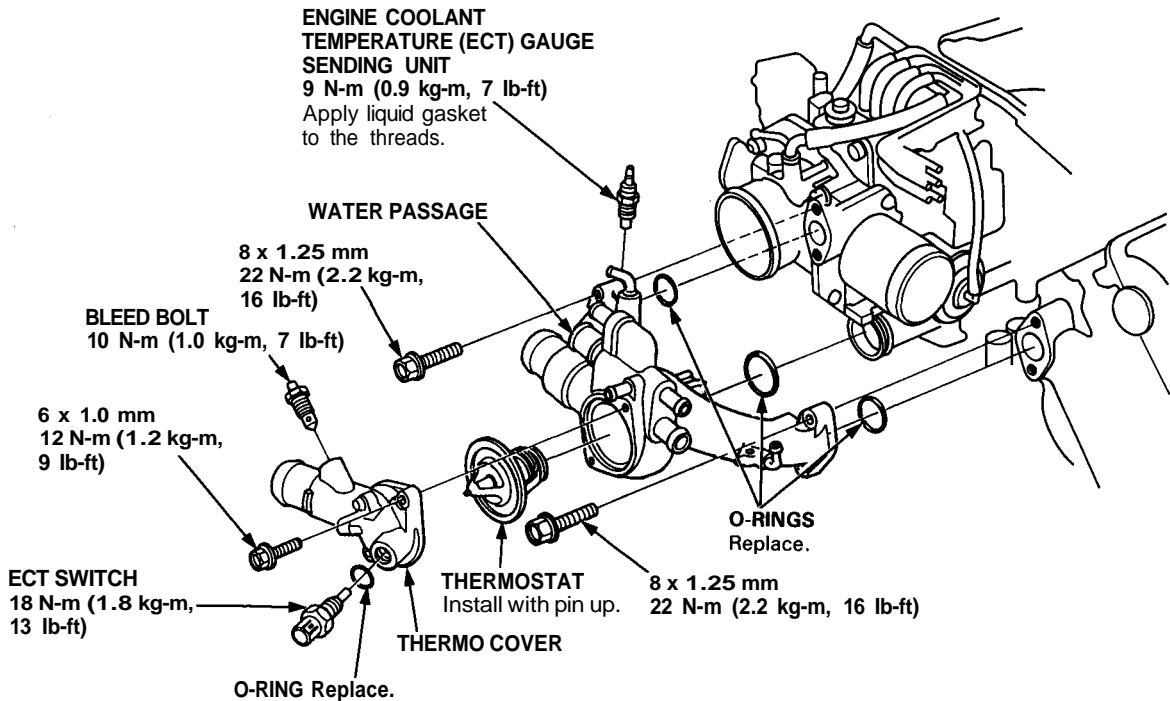

Thermostat

Replacement

NOTE: Use new gaskets and O-rings when reassembling.



Testing

Replace thermostat if it is open at room temperature.

To test a closed thermostat:

1. Suspend the thermostat in a container of water as shown.
2. Heat the water, and check the temperature with a thermometer. Check the temperature at which the thermostat first opens and at full lift.

CAUTION: Do not let thermometer touch the bottom of the hot container.

3. Measure lift height of the thermostat when fully open.

STANDARD THERMOSTAT

Lift height: above 10 mm (0.39 in)
Starts opening: 169-176°F (76-80°C)
Fully open: 194°F (90°C)

