

# PGM-FI System

## Engine Control Module (ECM) (cont'd)

**The Malfunction Indicator Lamp (MIL) stays on or comes on after two seconds.**

**Check the Diagnostic Trouble Code (DTC):**

1. Connect a scan tool or Honda PGM Tester.
2. Turn the ignition switch ON (II).
3. Read the DTC with the scan tool or Honda PGM Tester.

NOTE:

- When there is no Diagnostic Trouble Code (DTC) stored, the MIL will stay on if the SCS service connector is connected and the ignition switch is on.
- If this symptom is intermittent, check for:
  - A loose ACG(S) (20 A) fuse in the engine compartment fuse/relay box
  - A loose No. 2 FUEL PUMP SRS2 (15 A) fuse in the under-dash fuse box
  - An intermittent short in the wire between the ECM (C5) and the service check connector
  - An intermittent open in the wires between the ECM (A26, B14) and the service check connector
  - An intermittent short in the wire between the ECM (A7) and the gauge assembly
  - An intermittent short in the wire between the ECM (F1) and the MAP sensor, accelerator position sensor
  - An intermittent short in the wire between the ECM (D10) and the TP sensor, EGR valve lift sensor
  - An intermittent short in the wire between the ECM (F14) and accelerator position sensor
- See the OBD-II scan tool or Honda PGM Tester user's manuals for specific operating instructions.

Are any DTC(s) indicated?

YES

**Go to troubleshooting procedures. (see page 11-38)**

NO

**Check the DTC by MIL indication:**

1. Turn the ignition switch OFF.
2. Connect the SCS service connector to the service check connector.
3. Turn the ignition switch ON (II).

Does the MIL indicate any DTC?

YES

**— Repair open or short in wire between the ECM (D4) and Data Link Connector.  
— Go to troubleshooting procedures. (see page 11-38)**

NO

Try to start the engine.

Does the engine start?

NO



(To page 11-63)

YES

**Check for a short in the wires (SCS line):**

1. Stop the engine and turn the ignition switch ON (II).
2. Measure voltage between the ECM connector terminal C5 and body ground.

Is there approx. 5 V?

NO

**Repair short to body ground in the wire between ECM (C5) and service check connector.**

YES

(To page 11-63)



(From page 11-62)

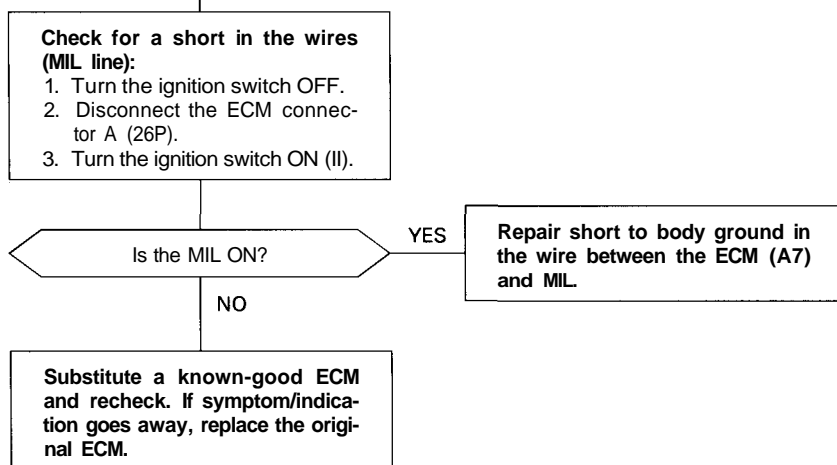

(From page 11-62)

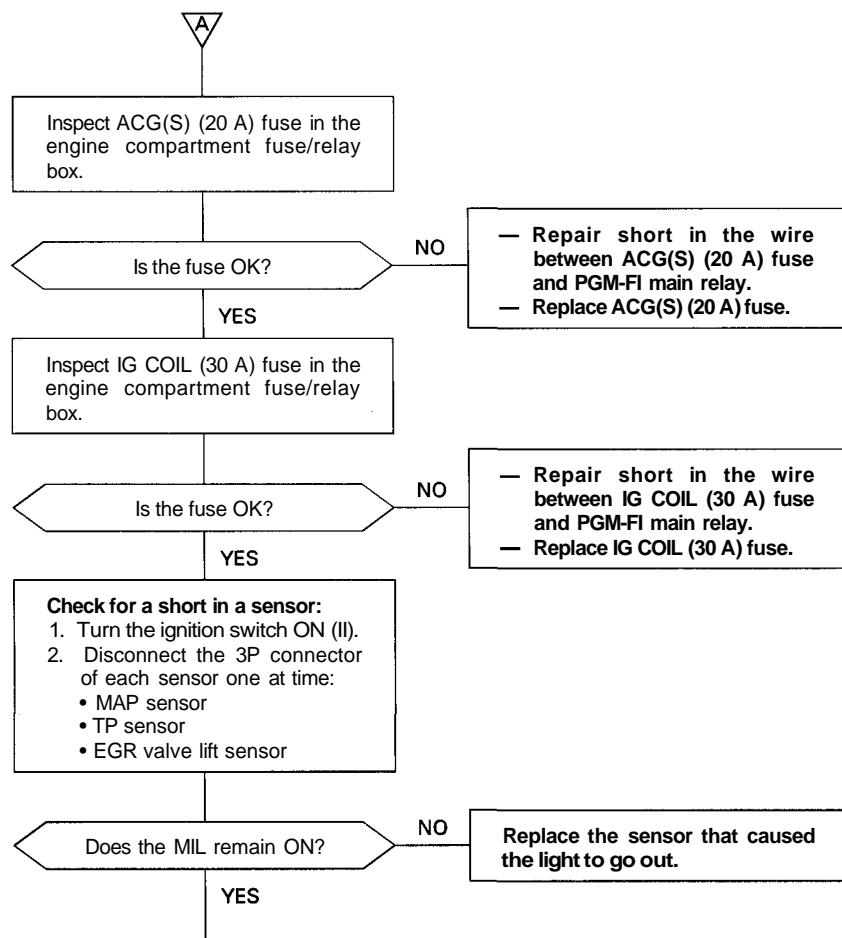

(To page 11-64)

(cont'd)

# PGM-FI System

## Engine Control Module (ECM) (cont'd)

(From page 11-63)

### Check for a short in the AP sensor:

1. Turn the ignition switch OFF.
2. Connect the SCS service connector.
3. Disconnect the AP sensor 3P connector.
4. Turn the ignition switch ON (II).

Is DTC P1246 and/or P1247 indicated?

YES

Replace the AP sensor.

NO

### Check for a short in the wires (VCC lines):

1. Turn the ignition switch OFF.
2. Disconnect the ECM connector D (22P) and F (26P).
3. Check for continuity between body ground and ECM connector terminals D10, F1 and F14 individually.

Is there continuity?

YES

- Repair short to body ground in the wire between ECM (D10) and throttle angle sensor and EGR valve lift sensor.
- Repair short to body ground in the wire between ECM (F1) and MAP sensor or Accelerator Position sensor.
- Repair short to body ground in the wire between ECM (F14) and Accelerator Position sensor.

NO

### Check for an open in the wires (IGP lines):

1. Turn the ignition switch ON (II).
2. Measure voltage between body ground and ECM connector terminals A13 and C1 individually.

Is there battery voltage?

NO

- Repair open in the wire(s) between ECM (A13, CD and PGM-FI main relay).
- Check for poor connections or loose wires at the PGM-FI main relay.

YES

### Check for an open in the wires (LG lines):

1. Reconnect all sensor connectors.
2. Reconnect the ECM connector D (22P) F (26P).
3. Turn the ignition switch ON (II).
4. Measure voltage between body ground and ECM connector terminals A26 and B9 individually.

Is there less than 1.0 V?

NO

Repair open in the wire(s) between ECM (A26, B9) and G101 that had more than 1.0 V.

YES

Substitute a known-good ECM and recheck. If symptom/indication goes away, replace the original ECM.

