



Front Wheel Alignment Adjusting Procedure

Adjustment

NOTE: NSX/NSX-T four wheel alignment requires the use of equipment designed specifically for four wheel independent suspensions and capable of immediate feedback.

The NSX/NSX-T suspension can be adjusted for camber, caster (front only), and toe. However, because each of them relates to the other, the camber changes when the toe is adjusted for example. Therefore, the total adjustment of the front/rear wheel alignment is required whenever one of the elements (camber, caster, or toe) is adjusted.

Front wheel alignment adjusting procedure

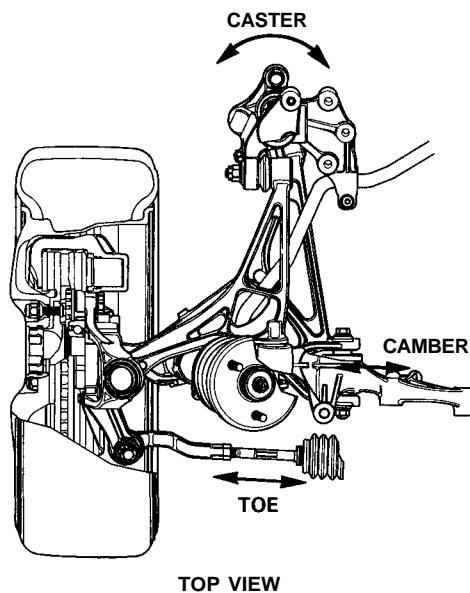
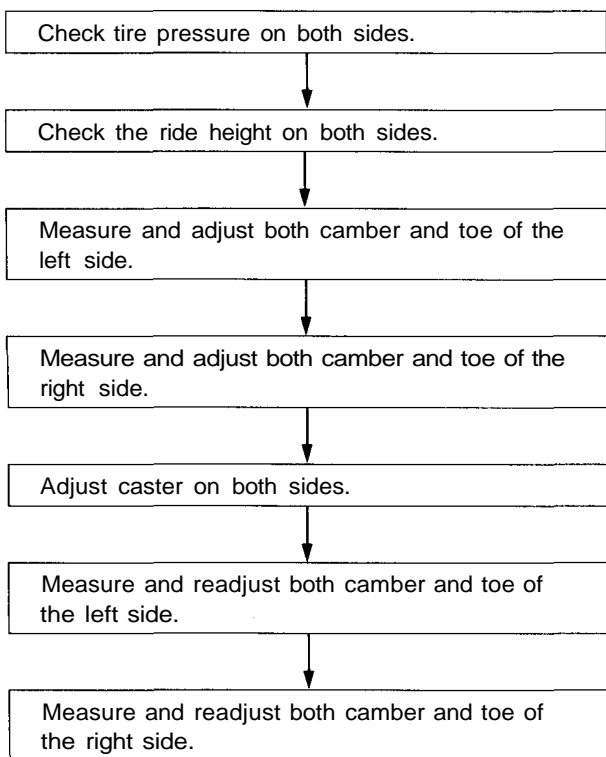

(cont'd)

Wheel Alignment

Front Wheel Alignment Adjustment Procedure (cont'd)

NOTE:

- NSX/NSX-T four wheel alignment requires the use of equipment designed specifically for four wheel independent suspensions and capable of immediate feedback.
- The ride height is very important for setting the alignment. For every 10 mm (0.4 in) of change in the front ride height, the camber will change approximately 10 minutes.
- The front alignment settings on the NSX are interactive.
- A slight change in toe will dramatically change the camber.
- Always inspect and adjust the front wheel alignment with the steering wheel in the straight ahead position.

1. Drive the car on the alignment rack.
2. Check the tire pressure and ride height (see page 18-6).
3. Center the steering wheel in the straight ahead position, and lock it in place with the steering lock.
4. Set the alignment equipment following the manufacturer's instructions.
5. Measure and adjust the camber and toe on the left side, then measure and adjust the right side.

Toe:

- Loosen the locknut, and turn the right and left tie-rods to adjust the front toe.

LOCKNUT

44 N-m
(4.4 kg-m, 32 lb-ft)

TIE-ROD

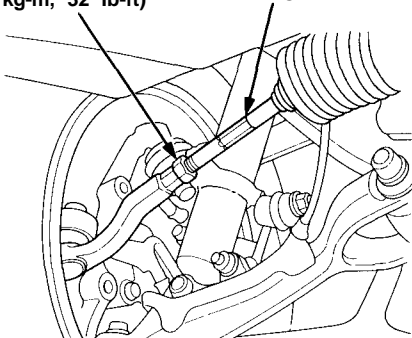

Camber:

- Loosen the self-locking nut on the front lower control arm adjusting point, and adjust the camber by turning the adjusting cam.

☆ SELF-LOCKING NUT
Replace.
125 N-m
(12.5 kg-m, 90 lb-ft)

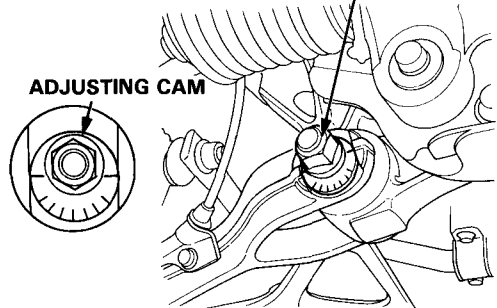

☆: Corrosion resistant bolt/nut



6. Measure the caster on the both sides, and adjust the caster to specifications.

Caster:

- Loosen the pivot adjuster mounting nuts (self-locking nuts) under the compliance pivot, and adjust the caster by turning the adjusting cam.

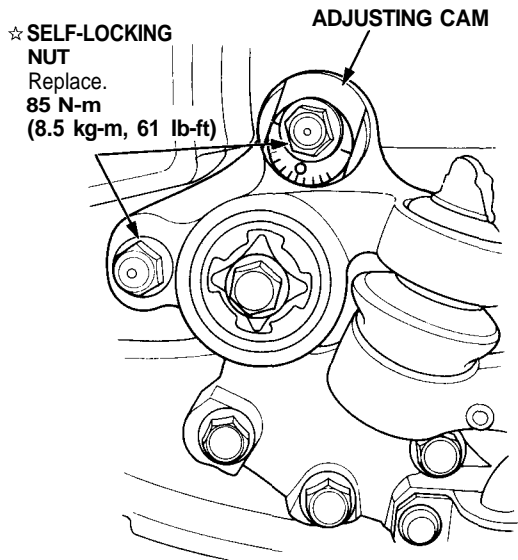

☆: Corrosion resistant bolt/nut

7. Remeasure and, if necessary, adjust the camber and toe on the left side first, then the right side.

Front Specifications

Toe-out: 3.5 ± 1.0 mm (0.14 ± 0.04 in)

Camber: $-0^{\circ} 20' \pm 30'$

Caster: $8^{\circ} 00' \pm 45'$