

Electronic Components

Steering Angle Sensor Replacement

Removal

1. Remove the steering column covers.

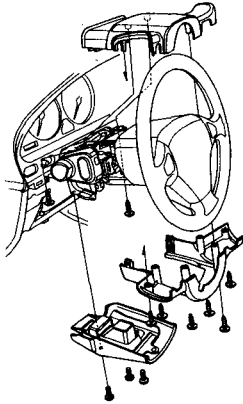

2. Disconnect the 5P connector from the steering angle sensor.
3. Remove the steering angle sensor mounting bolts and washers, then remove the steering angle sensor.

NOTE: Do not lose the adjusting shims used between the steering angle sensor and sensor mounting bracket.

CAUTION: Do not damage or drop the steering angle sensor as it is sensitive.

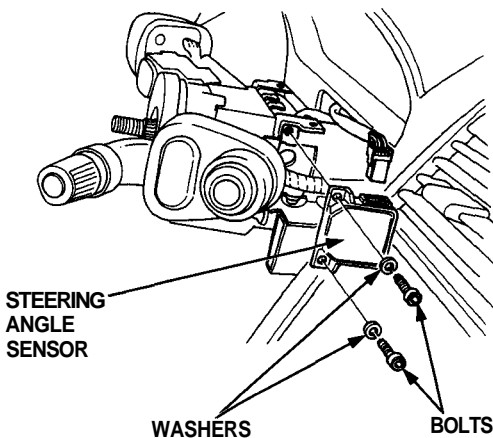

Installation

1. Install the steering angle sensor by tightening two bolts, and make sure the adjusting shims are installed properly.

CAUTION: Do not apply any grease or oil to the adjusting shim.

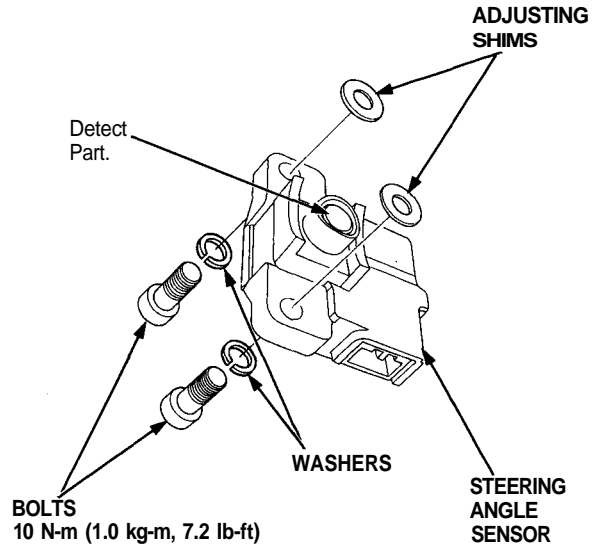

2. Connect the 5P connector to the steering angle sensor.
3. Install the steering column covers.
4. Perform the steering angle sensor system check (see next page).

NOTE:

- There is no need to select (replace) the shims when the steering angle sensor is replaced. Use the original shims.
- Selection (Replacement) of the adjusting shims (for adjusting the air gap) is required only when the steering column assembly (without the sensor) is replaced.



Steering angle sensor system check

1. Start the engine,
2. Push the TCS switch three times within three seconds.

NOTE: Always maintain the same number of rotations.

3. Turn the steering wheel slowly from left to right more than 1.5 turns.

NOTE:

- Start checking after the steering wheel moves at least 1.5 turns from right to left.
- Turn the steering wheel slowly, no faster than one turn in four seconds.

4. Push the TCS switch twice within three seconds.

NOTE: Always maintain the same number of rotations.

5. Return the steering wheel to the left side slowly, and check the number of times the TCS indicator light flashes after the wheel has moved approximately one turn.

NOTE:

- Start the check from the beginning when the steering wheel moves at least one turn from left to right,
- Turn the steering wheel slowly, no faster than one turn in four seconds.

Standard number of times the TCS indicator light flashes:

Manual Transmission: 5 times

Automatic Transmission: 2 times

6. If there is an abnormality, check the troubleshooting flowchart (see page 19-98('91-'93)('94-'96))

Selection of the adjusting shims for the steering angle sensor air gap adjustment

NOTE:

- The adjustment of the air gap between the steering shaft and the steering angle sensor should be carried out in order to obtain adequate sensor output.
- The adjusting shim reference number is stamped on the steering column. Select the adjusting shims that match the reference number using the table below.

Reference Number Locations

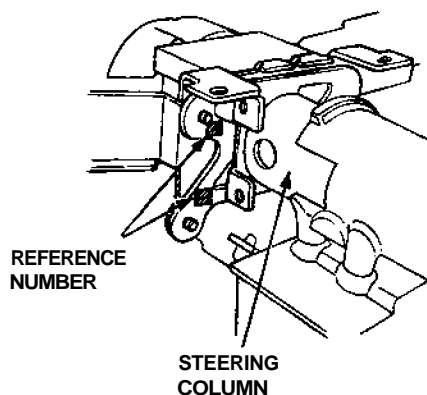

Selection of The Adjusting Shim

Reference Number	Shim (P/N): (Thickness)
1	Not used: (0 mm)
2	A: (0,1 mm)
3	B: (0.2 mm)
4	A + B: (0.3 mm)
5	C: (0.4 mm)
6	A + C: (0.5 mm)
7	B + C: (0.6 mm)
8	D: (0.7 mm)

Adjusting Shim

Parts Number	Thickness	Color
A:53395-SL0-A01	0.1 mm	Yellow
B: 53396-SL0-A01	0.2 mm	Black
C: 53397-SL0-A01	0.4 mm	Green
D: 53398-SL0-A01	0.7 mm	White