

Roof

Roof Side Seal/Retainer Replacement

CAUTION: To prevent damage, place the roof on an appropriate pad.

1. Remove the roof.
2. Remove the roof front trim and roof side trim (see page 20-82).
3. Remove the screws from each end of the roof side seal.

►: Screw locations

A ►, 2

B ►, 2

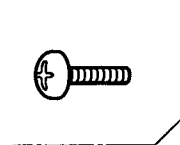
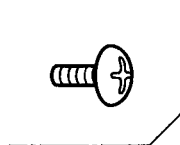

Front:

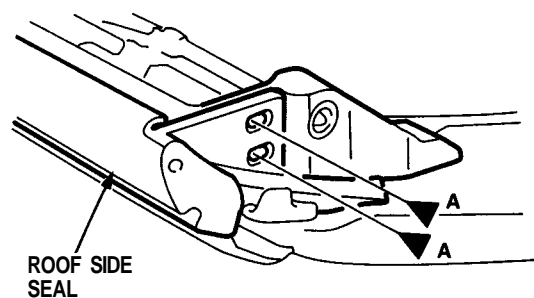

Rear:

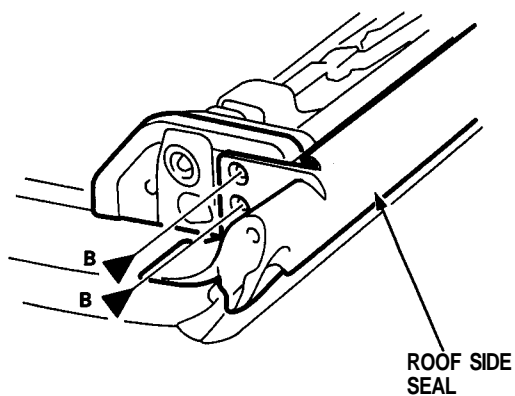



- Remove the bonded portion of the roof side seal from one end, then pull the seal away from the roof side retainer, and remove the bonded portion from the other end.

NOTE:

- If the old roof side seal is to be reinstalled, take care not to damage it.
- If the roof side seal is damaged, replace it with new one.
- When removing the bonded portions of each roof side seal, remove them gradually.

Rear:

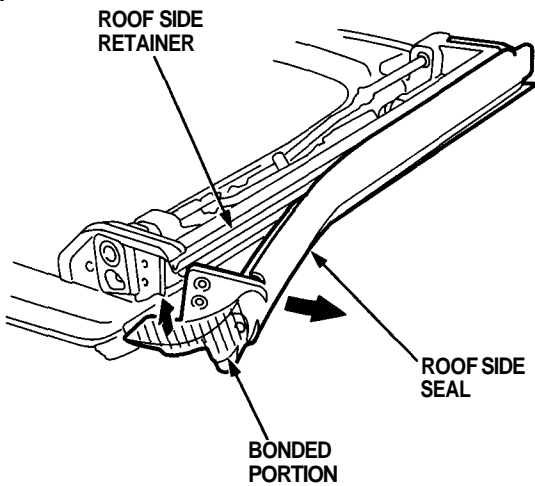

Front:

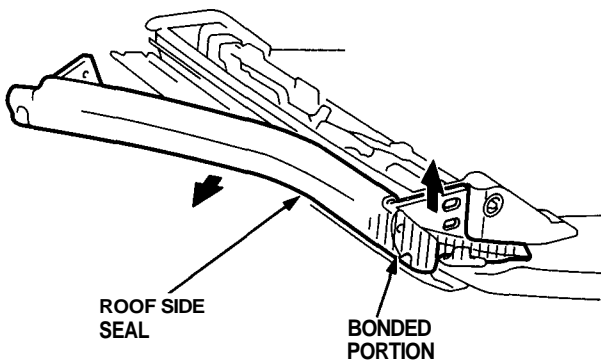

- Remove the screws, then remove the roof side retainer.

►: Screw locations, 3

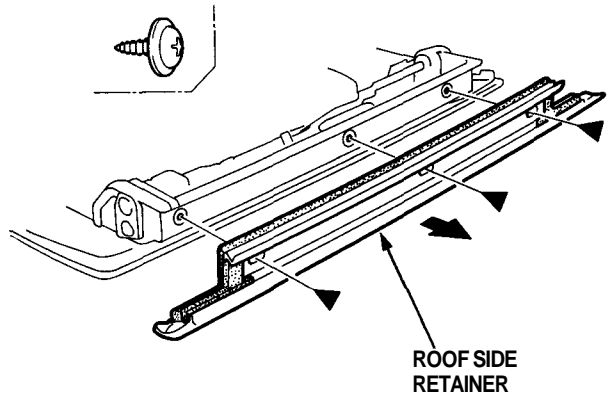

- Scrape the old sealant and EPT sealer from the roof bonding surfaces with a putty knife.

NOTE: Do not scrape down to the painted surfaces of the roof.

- Clean the roof bonding surfaces with a sponge dampened in alcohol.

NOTE: After cleaning, keep oil, grease and water from getting on the surface.

- If the old roof side retainer is to be reinstalled, use a putty knife to scrape off all traces of old sealant and the EPT sealer, then clean the roof side retainer surface with alcohol where new sealant and EPT sealer are to be applied.

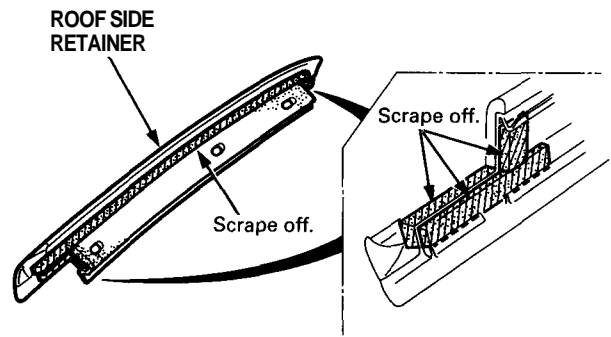

(cont'd)

Roof

Roof Side Seal/Retainer Replacement (cont'd)

9. If the old roof side retainer is to be reinstalled, glue the new EPT sealer to it as shown.

NOTE: Be careful not to touch the roof side retainer where the EPT sealer will be applied.

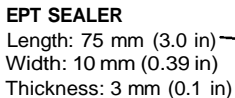
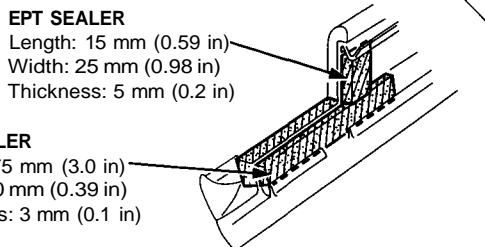
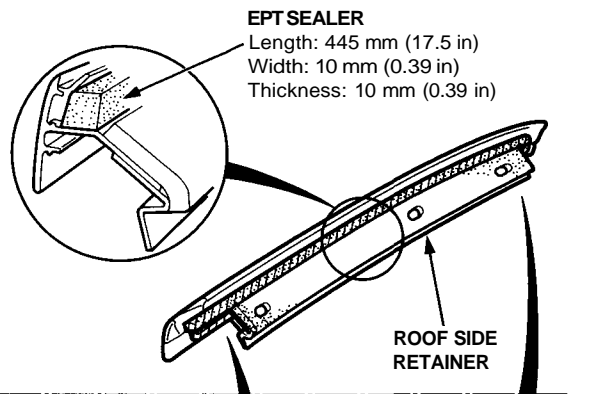

10. If the old roof side seal is to be reinstalled, scrape the old butyl tape from each end of it, then clean each end with alcohol. Glue the new butyl tape on each end as shown.

Butyl tape thickness: 0.5 mm (0.02 in)

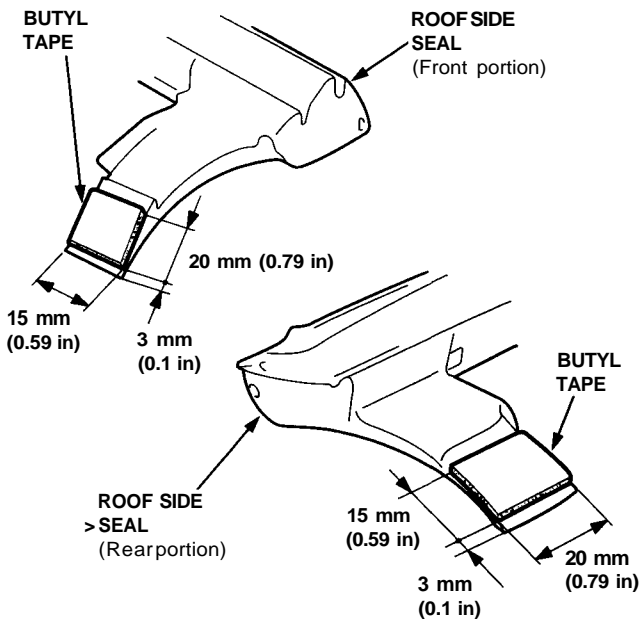

11. Install the roof side retainer.

NOTE:

- Be careful not to touch the roof side retainer where sealant will be applied.
- Align each end of the roof side retainer with the roof corner edges.

►: Screw locations, 3

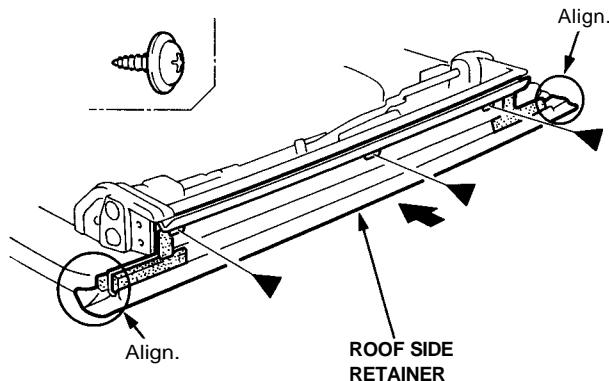

12. Glue the new EPT sealer on the roof as shown.

EPT sealer thickness: 3.0 mm (0.12 in)

Front:

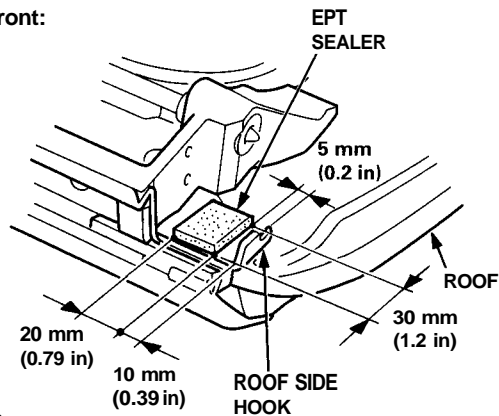

Rear:

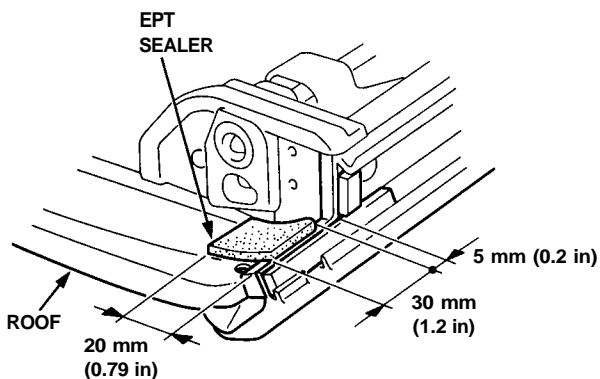



13. Apply new sealant to the roof and roof side retainer as shown.

 : Sealant locations
(Cemadine P/N 08712 - 0004, or equivalent)

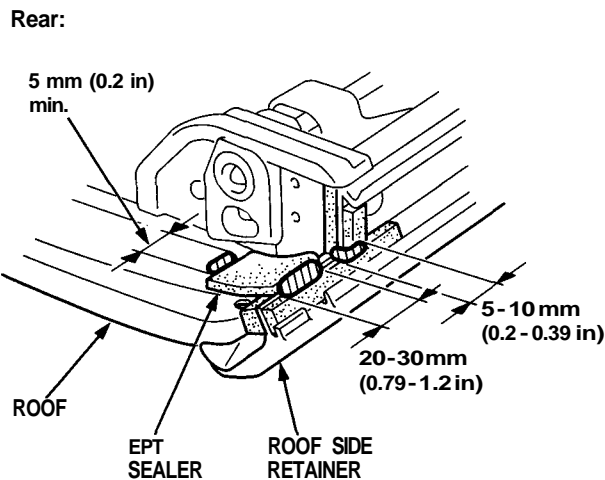
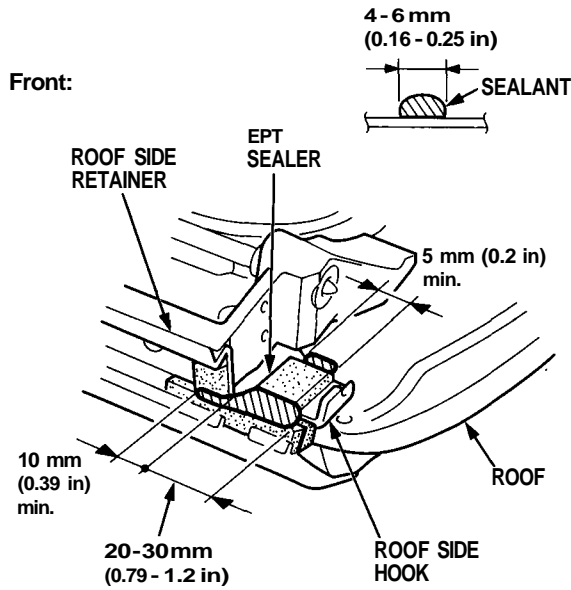

14. Engage the lip of the roof side seal with the groove of the roof side retainer as shown, then gently set each end of the roof side seal down on the sealant.

NOTE:

- Do not press on the seal yet to make the adhesive stick.
- Remove the separator from the butyl tape on each end of the roof side seal.

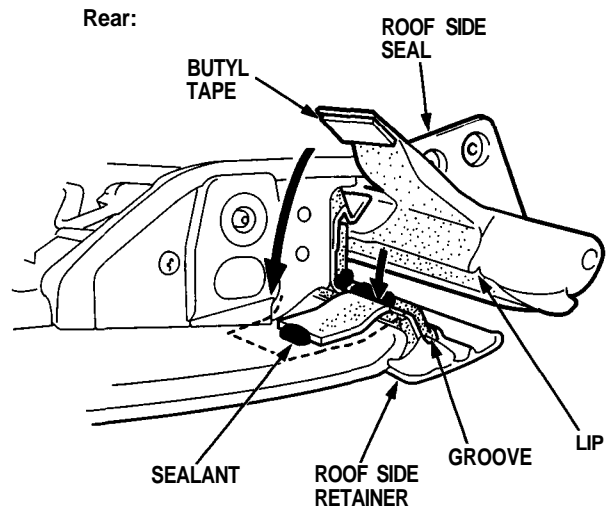
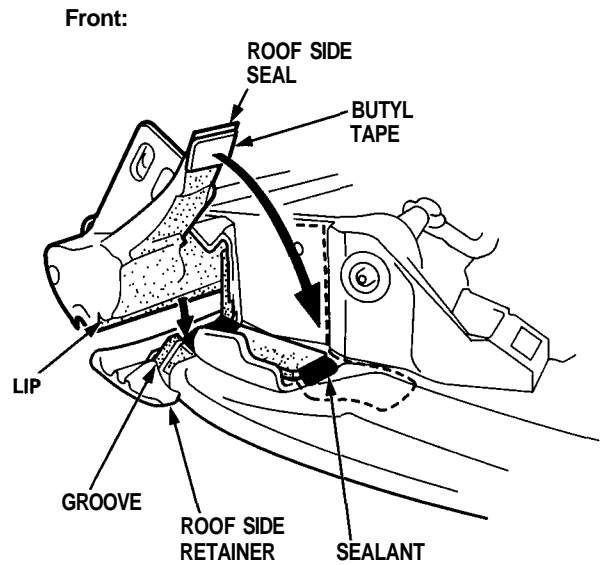

(cont'd)

Roof

Roof Side Seal/Retainer Replacement (cont'd)

15. Install the screws on each end of the roof side seal.

NOTE: Do not press on the seal yet to make the adhesive stick.

►: Screw locations

A ►, 2



4 x 0.7 mm
1.5 N-m (0.15 kg-m,
1.1 lb-ft)

B ►, 2



4 x 0.7 mm
1.5 N-m (0.15 kg-m,
1.1 lb-ft)

Front:

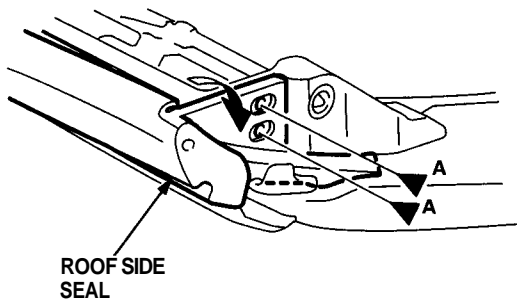

Rear:

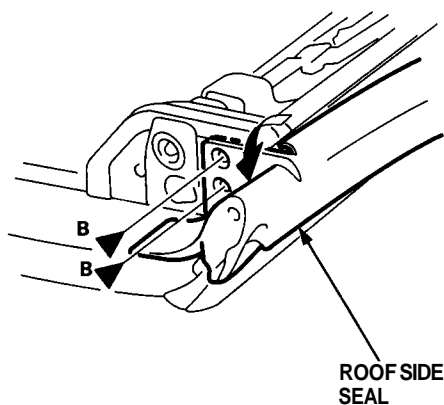

16. Install the side portion of the roof side seal into the roof side retainer as shown.

NOTE:

- Do not press on the seal yet to make the adhesive stick.
- After setting the lip at location (A), install the roof side seal while pushing the lip in the roof side retainer with a rounded plastic spatula at location (B).

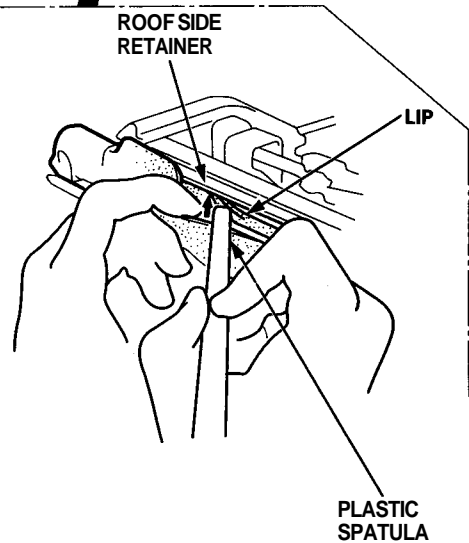
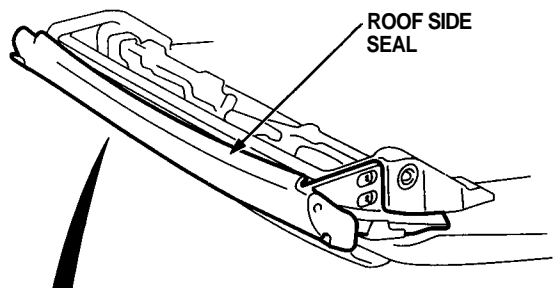
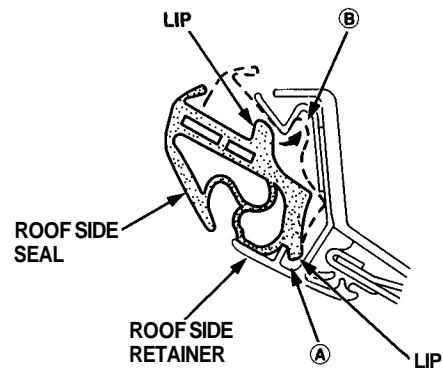



17. Scrape or wipe the excess sealant off with a putty knife or towel.

NOTE: To remove sealant from a painted surface or the roof side seal, wipe with a soft shop towel dampened with alcohol.

18. Let the roof stand for at least three hours after installing the roof side seal.
19. Before installing the roof trim, install the roof on the body, then check that the seal fits flush (see page [20-107](#)).
If necessary, align the roof side seal by adjusting the roof side lock unit (see page [20-106](#)).
When you are satisfied that the seal fits properly, press on the seal to make the adhesive stick.
20. Check that the door glass contacts the seal evenly (see page [20-109](#)).
21. Check for water leaks (see page [20-110](#)).
22. Remove the roof, then install the roof trim (see page [20-82](#)).