

Seals/Retainers Alignment

Adjustment

NOTE: When the following parts have been replaced or removed, this adjustment should be done.

- Roof side seals
- Roof side lock units
- Front and rear pillar seals

CAUTION: To prevent damage, place the roof on an appropriate pad.

1. Remove the roof front trim and roof side trim (see page 20-82).
2. Install the roof side lock handle.
3. Turn the roof side lock handle to the locked position.
4. Loosen the roof side lock unit mounting nuts, then tighten them lightly.

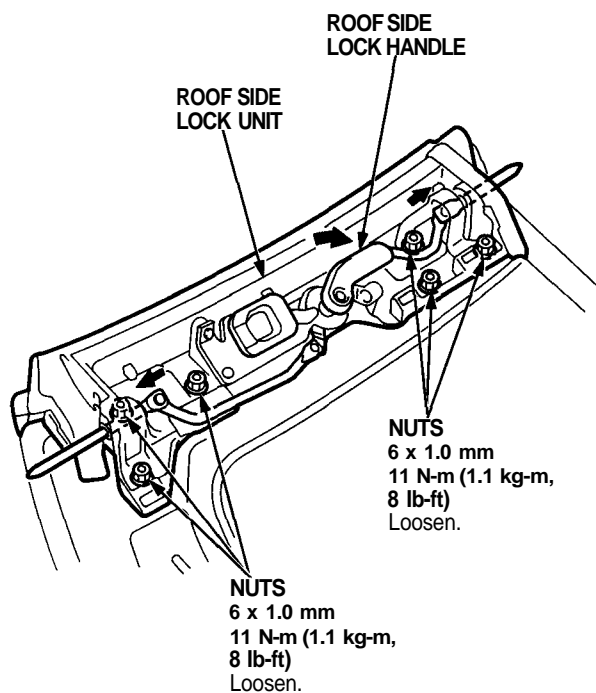

5. Return the roof side lock handle to the unlocked position.

6. Remove the front and rear roof rail trim (see page 20-79).
7. Loosen the lock receiver mounting bolts at each of the four corners, then tighten them lightly.

Front:

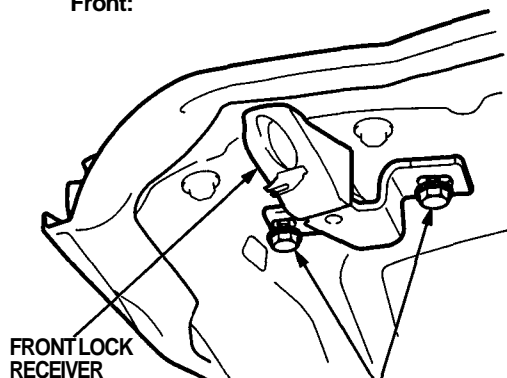

Rear:

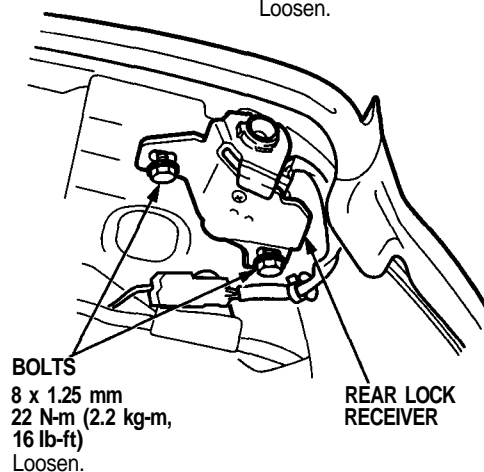

8. Install the roof on the body.

CAUTION: When installing the roof, make sure both roof side locks are unlocked.

NOTE: Make sure each roof side hook aligns with the hook stop properly.

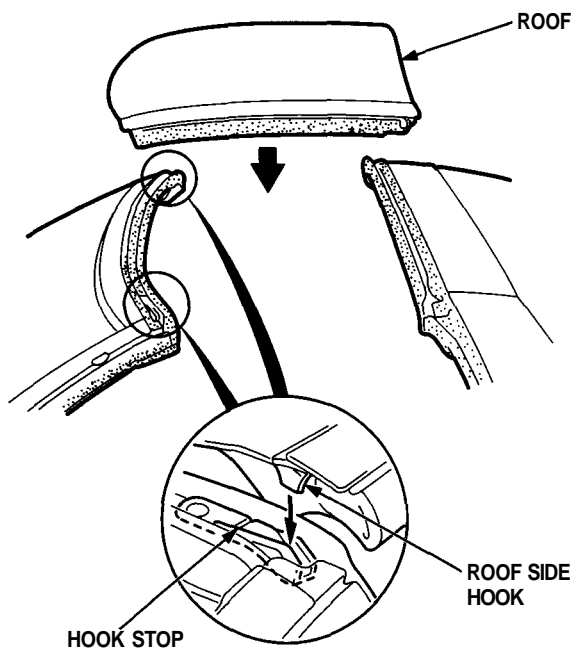

9. Secure the roof by turning both roof side lock handles. Make sure they are locked securely.

NOTE: Turn each roof side lock handle until a faint click is heard.

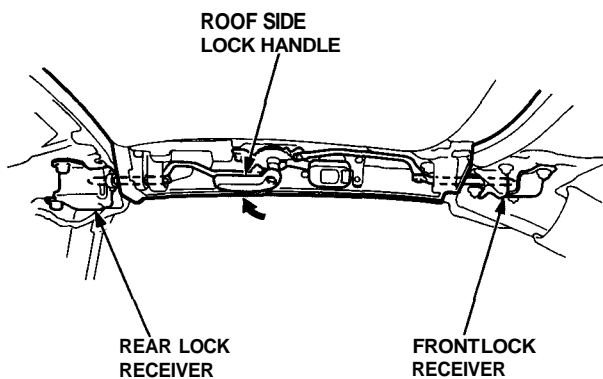

10. Check the seal and retainer alignment.
- Each seal joint fits flush.
 - Each retainer aligns.

11. Adjust the seal and retainer alignment by moving both roof side lock units in or out.

NOTE: Align the roof side retainer with the front pillar retainer and rear pillar panel evenly on each side, and make the seals fit flush.

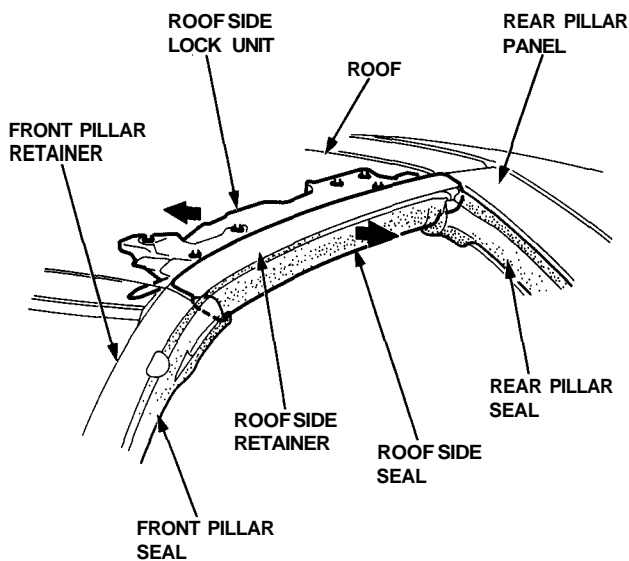

Front:

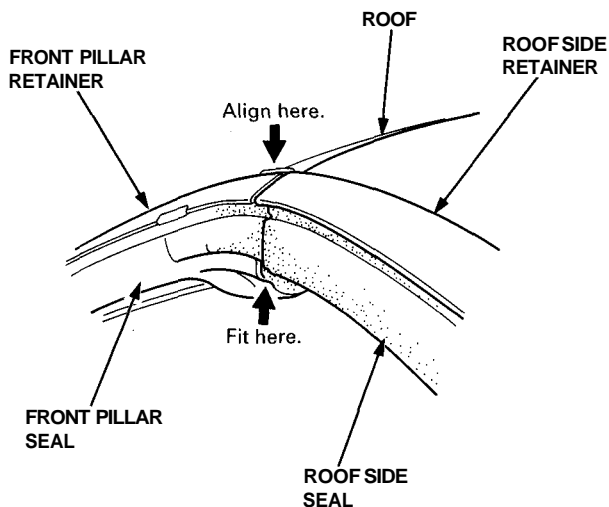

(cont'd)

Seals/Retainers Alignment

Adjustment (cont'd)

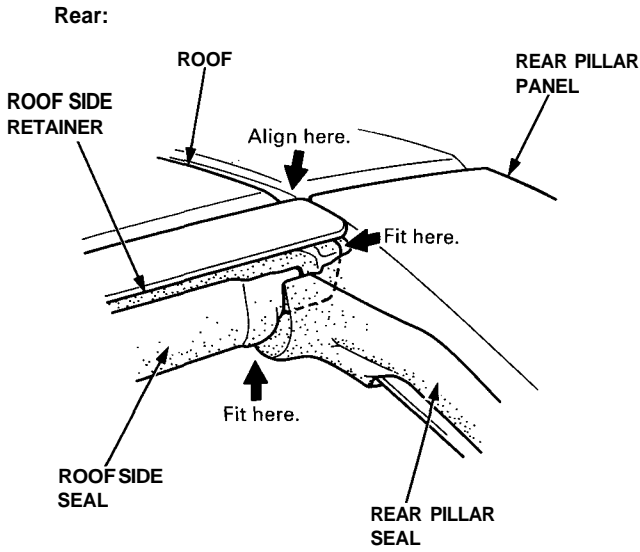

12. Tighten the roof side lock unit mounting nuts and lock receiver mounting bolts.

13. If you need to adjust the rear end of the roof side seal to fit against the rear pillar seal, remove the roof, then adjust the rear end of the roof side seal with a shim.

NOTE:

- Remove the rear end of the roof side seal, then install the shim.
- Install the roof side seal securely as described on page [20-85](#).

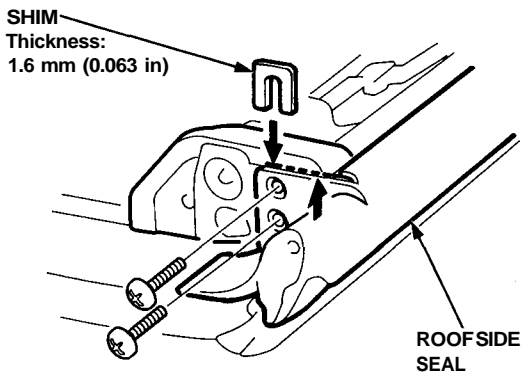

14. Check the height of the roof with the body. If necessary, loosen the lock receiver mounting bolts, then adjust the height of the roof to make the roof fit flush with the body by using shims.

➔ : Shim locations

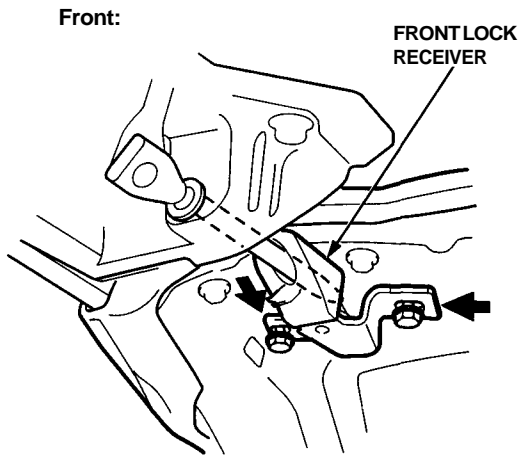

Rear:

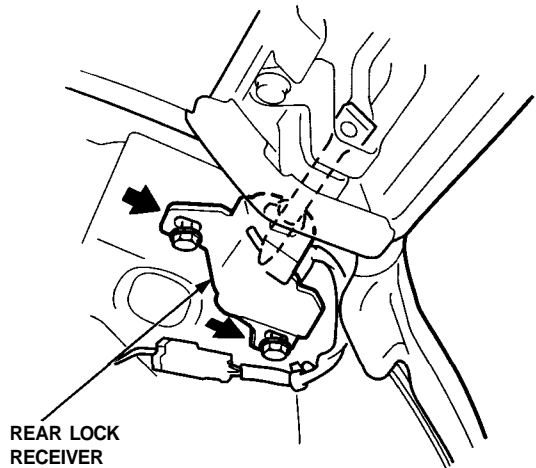

15. Tighten the lock receiver mounting bolts.



16. Check that each roof side lock handle works smoothly.
17. Remove the roof.
18. If the roof side retainer has not been replaced, and or the EPT sealer on the roof side retainer has not been replaced, do the following (see page 20-84):
 - a. Remove the roof side seal and roof side retainer from the roof.
 - b. Replace the EPT sealer on the roof side retainer and roof.
 - c. Replace the butyl tapes on the roof side seal.
 - d. Reinstall the roof side retainer, then apply new sealant.
 - e. Reinstall the roof side seal.
19. Check the lips of the roof side seal, and glue the peeled lip securely with sealant, then wipe the excess sealant off with a soft shop towel dampened with alcohol.
20. After applying the sealant, let the roof stand for at least three hours.
21. Install the roof on the body, then make sure the seals fit flush.

NOTE: Make sure both roof side lock handles are locked securely.
22. Check that the door glass contacts the seal evenly as follows:
 - a. Raise the door glass fully, and close the door.

- b. Mark a line on the door glass using a thin plastic plate as shown.
- c. Open the door, then check that there is 1 - 3 mm (0.039-0.12 in) between the door glass edge and the a line around the front pillar and roof.
- d. If necessary, adjust the door glass (see page 20-14).

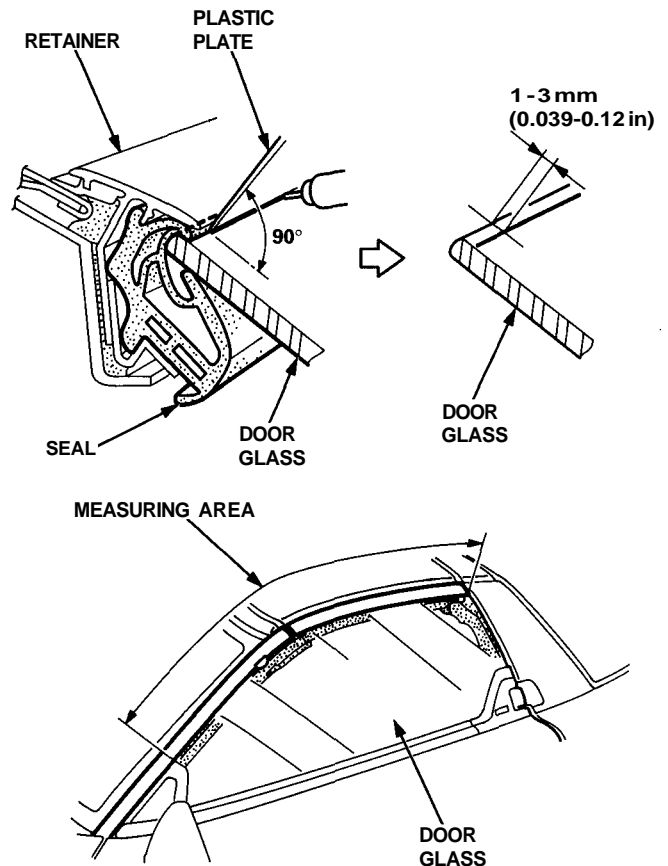

23. Check for water leaks (see page 20-110).
24. Remove the roof, then reinstall all remaining removed parts.