

# Charging System

## Alternator Overhaul

NOTE: It is only necessary to separate the pulley, drive end housing and rotor when the front bearing needs replacement.

Loosen the locknut with 10 mm and 22 mm wrenches to remove the pulley from the rotor. If necessary, use an impact wrench.

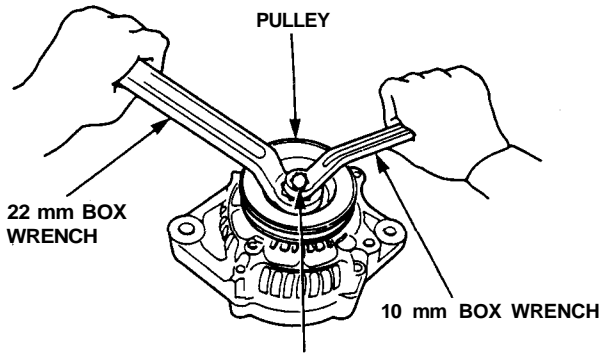

PULLEY LOCKNUT  
115 N-m (11.5 kg-m, 83 lb-ft)

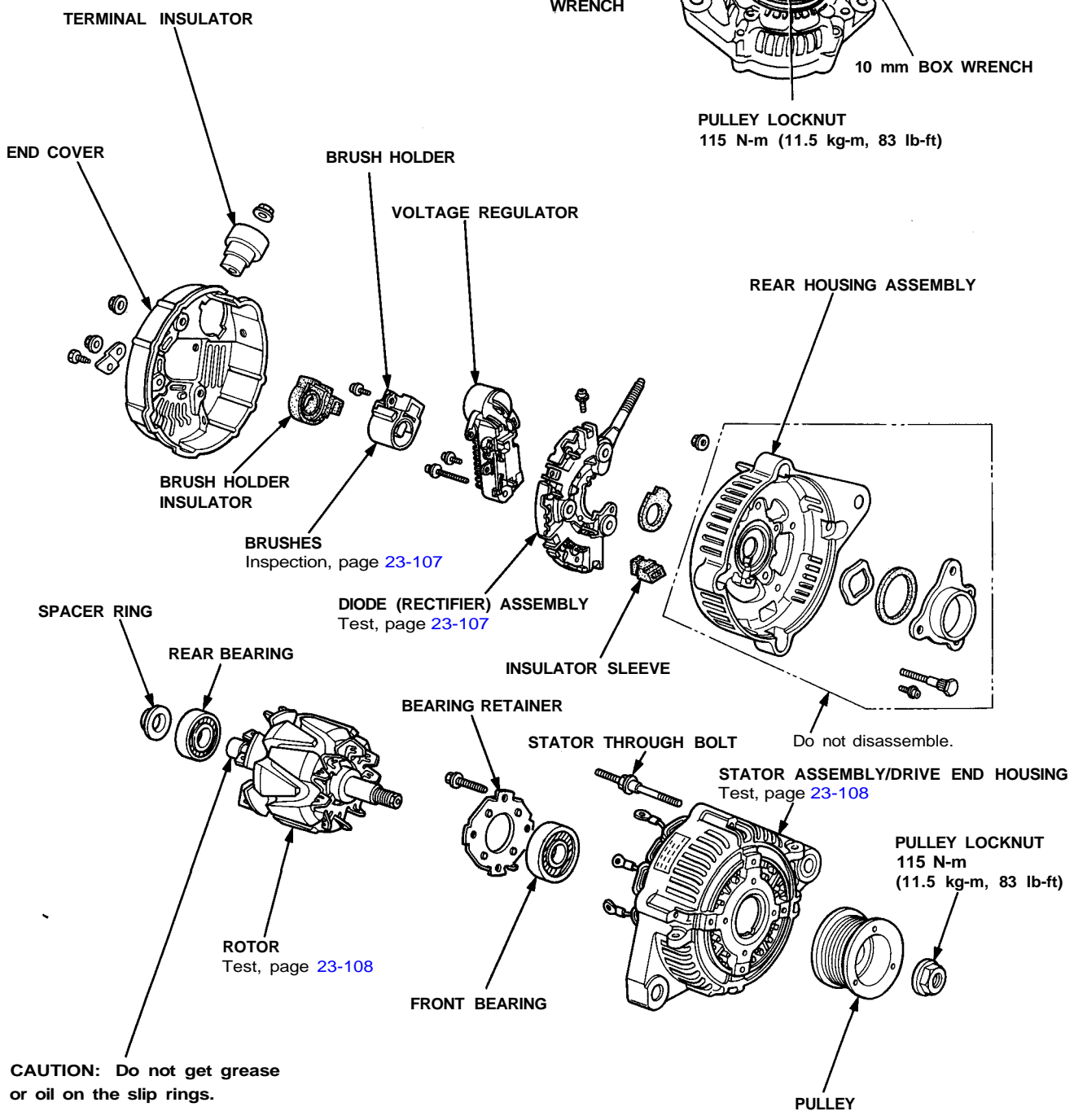

CAUTION: Do not get grease or oil on the slip rings.