

Engine Coolant Temperature (ECT) Gauge

ECT Gauge Test

1. Before testing, check the No. 5 (1.5 A) fuse in the under-dash fuse box.
2. Make sure the ignition switch is OFF, then disconnect the YEL/GRN wire from the ECT sending unit and ground it with a jumper wire.

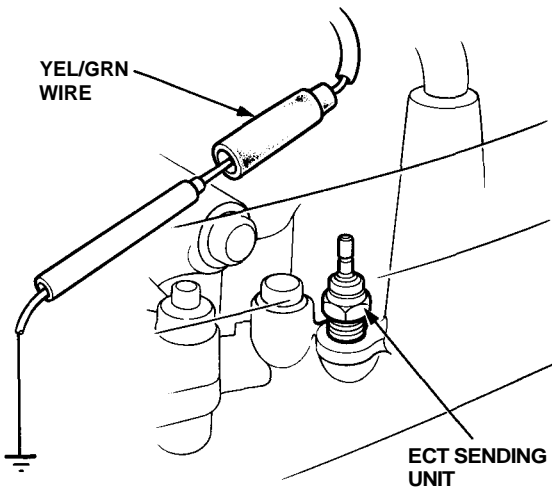

3. Turn the ignition switch ON (II). Check that the pointer of the ECT gauge starts moving toward the "H" mark.

CAUTION: Turn the ignition switch OFF before the pointer reaches the "H" mark on the gauge dial; if you don't, you may damage the gauge.

- If the pointer of the gauge does not swing at all, check for:
 - An open in the YEL or YEL/GRN wire.
 - Replace the ECT gauge if the fuse and wiring is OK.
- If the ECT gauge is OK, check the sending unit.

ECT Sending Unit Test

1. Disconnect the YEL/GRN wire from the sending unit, and with the engine cold, use an ohmmeter to measure resistance between the positive terminal and the engine (ground).

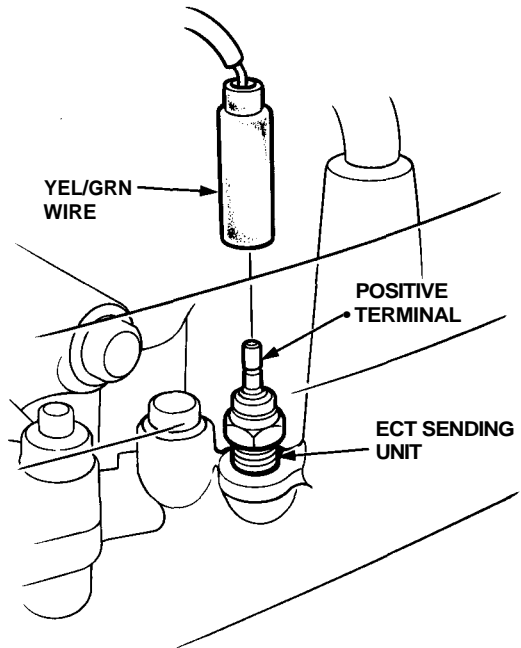

2. Check the temperature of the coolant.
3. Run the engine, and measure the change in resistance with the engine at operating temperature (radiator fan comes on).

Temperature	133°F (56°C) ["C" mark]	85°F (85°C) — 212°F (100°C)
Resistance (Ω)	142	49—32

4. If the readings you get are substantially different from the specifications above, replace the ECT sending unit.