

Switch Test

SRS components are located in this area. Review the SRS component locations, precautions, and procedures in the SRS ([section 24](#)) before performing repairs or service.

1. Disconnect the battery negative cable, then disconnect the positive cable.
2. Make sure the wheels are turned straight ahead.
3. Remove the dashboard lower cover.
4. Install the short connectors on the airbag and seat-belt tensioner connectors (see [section 24](#)).

(cont'd)

Horns

Switch Test (cont'd)

5. Disconnect the cable reel harness 6-P connector from the SRS main harness, then connect test harness C only to the cable reel harness.

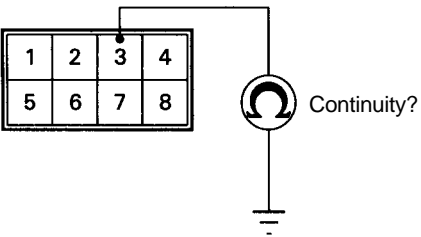
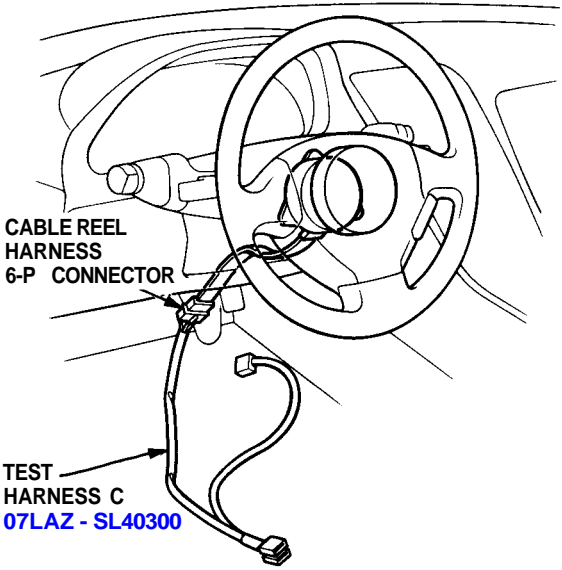

6. Check for continuity between the No. 3 terminal and body ground with the horn switch pressed. There should be continuity.
 - If there is continuity, the horn switch is OK.
 - If there is no continuity, go to step 7.

7. Remove the Torx bolts using a Torx T30 bit, then remove the airbag assembly.

⚠ WARNING Store a removed airbag assembly with the pad surface up. If the airbag is improperly stored face down, accidental deployment could propel the unit with enough force to cause serious injury.

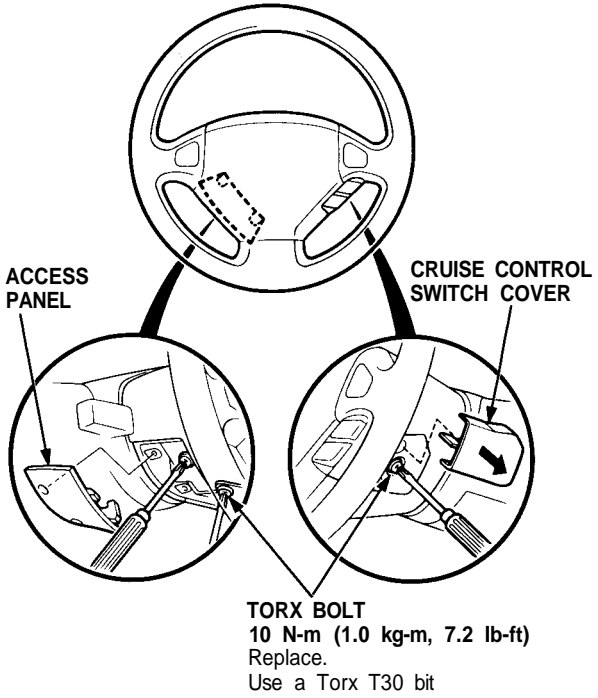



8. Check for continuity between the horn positive terminal and the steering column shaft with the horn switch pressed. There should be no continuity.

STEERING COLUMN SHAFT

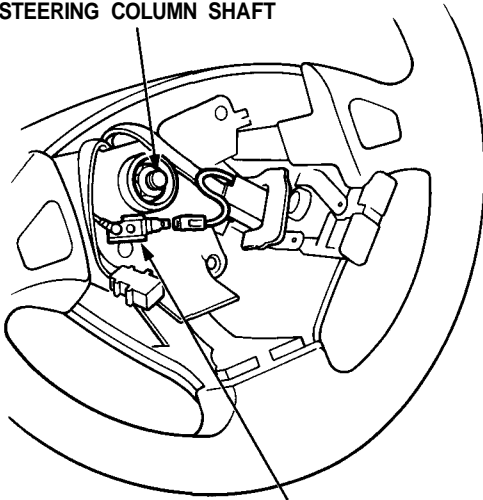

POSITIVE TERMINAL

- If there is continuity, replace the cable reel (see [section 24](#)).
 - If there is no continuity, go to step 9.
9. Remove the nut and the four screws, then remove the steering wheel cover, and replace the horn switch.

STEERING WHEEL NUT
50 N-m (5.0 kg-m, 36 lb-ft)
Replace.

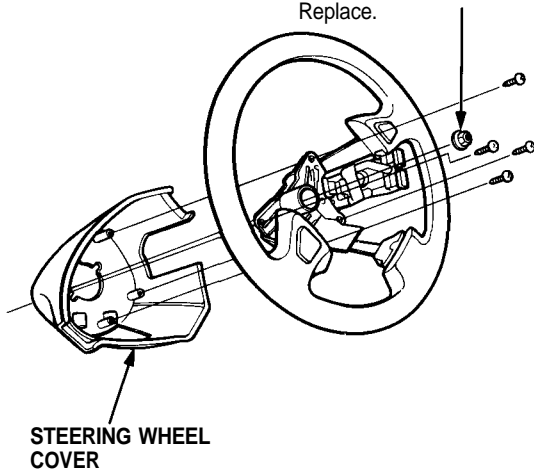

10. Reinstall the steering wheel and the airbag (see [section 24](#)).