

Steering Wheel

Installation

NOTE: Before installing the steering wheel, make sure the front wheels are straight ahead.

CAUTION:

- Be sure to install the harness wires so that they are not pinched or interfering with other car parts.
- Do not replace the original steering wheel with any other design, since it will make it impossible to properly install the airbag. (Use only genuine HONDA replacement parts.)
- After reassembly, confirm that the wheels are still straight ahead and that steering wheel spoke angle is correct. If minor spoke angle adjustment is necessary, adjust the tie-rods only. Do not remove and reposition the steering wheel.

⚠ WARNING Confirm that the airbag assembly is securely attached to the steering wheel; otherwise, severe personal injury could result during later airbag deployment.

1. Before installing the steering wheel, center the cable reel.
Do this by first rotating the cable reel clockwise until it stops.
Then rotate it counterclockwise (approximately two turns) until:
 - The yellow gear tooth lines up with the mark on the cover.
 - The arrow on the cable reel label points straight up.

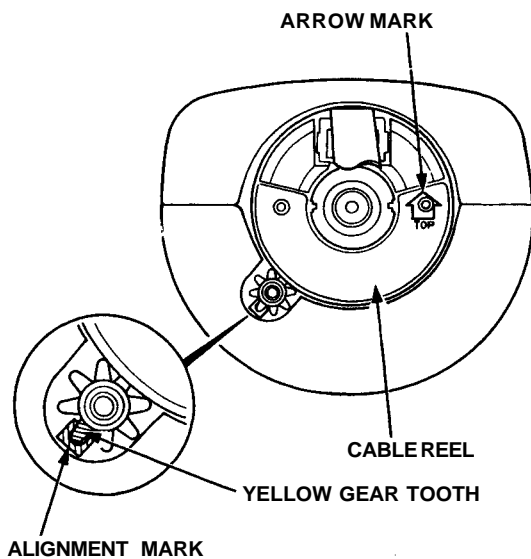

2. Install the steering wheel.
NOTE: Be sure the steering wheel shaft engages the cable reel.

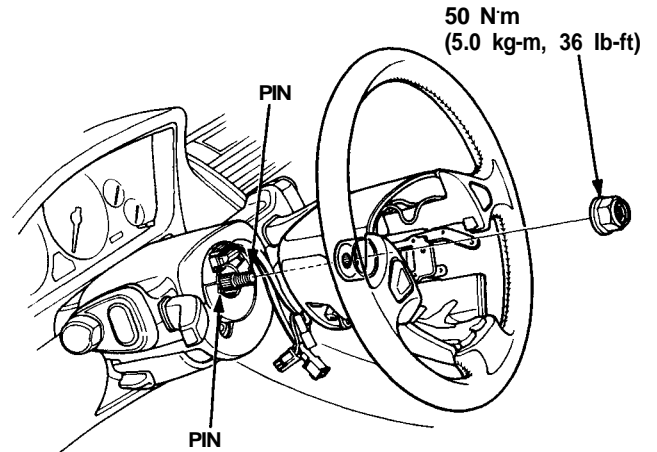

3. Insert the cruise control set/resume 4-P connector and airbag 3-P connector to the steering wheel clips.
4. Connect the horn connector.

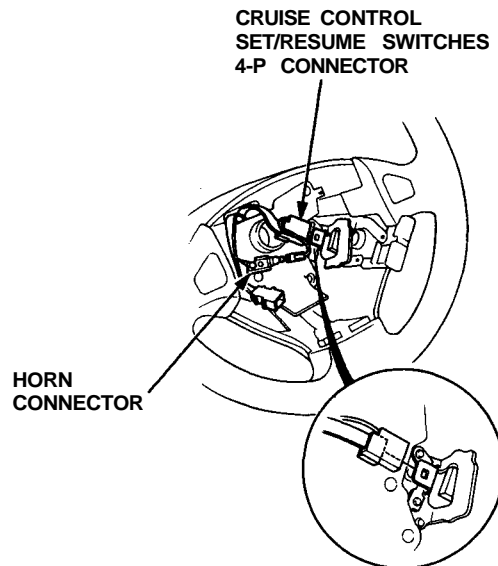



5. Install the airbag assembly with new TORX® bolts.

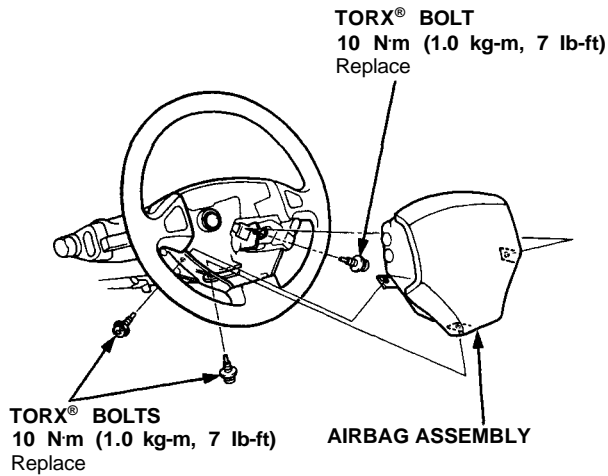

7. Disconnect the short connector from the airbag 3-P connector.
8. Connect the airbag 3-P connector and cable reel 3-P connector.
9. Attach the short connector to the access panel, and install the access panel on the steering wheel lower cover.

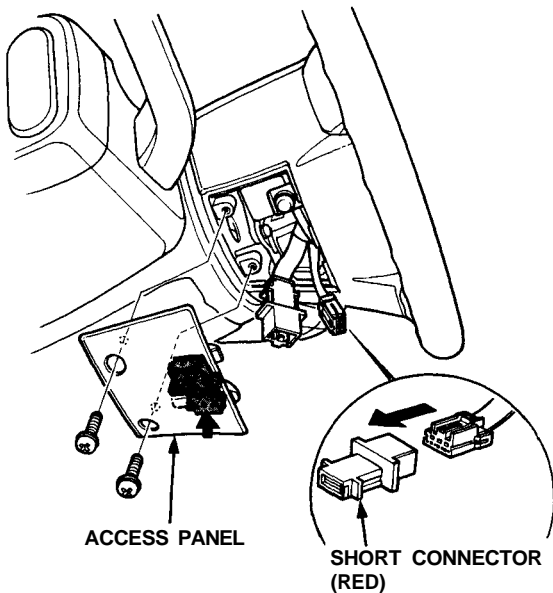

10. Connect the battery positive terminal and then connect the negative terminal.
11. After installing the airbag assembly, confirm proper system operation:
 - Turn the ignition to II: the instrument panel SRS indicator light should come on for about 6 seconds and then go off.
 - Confirm operation of horn buttons.
 - Confirm operation of cruise control set/resume switch.
 - Turn the steering wheel counterclockwise and make sure the yellow gear tooth still lines up with the alignment mark.

