

# Dashboard

## Component Removal/Installation

### Clock and center air vent removal:

NOTE: Take care not to scratch the dashboard and related parts.

1. Remove the clock by pulling it backward from the center air vent, then disconnect the connector.
2. Remove the center air vent mounting screws.

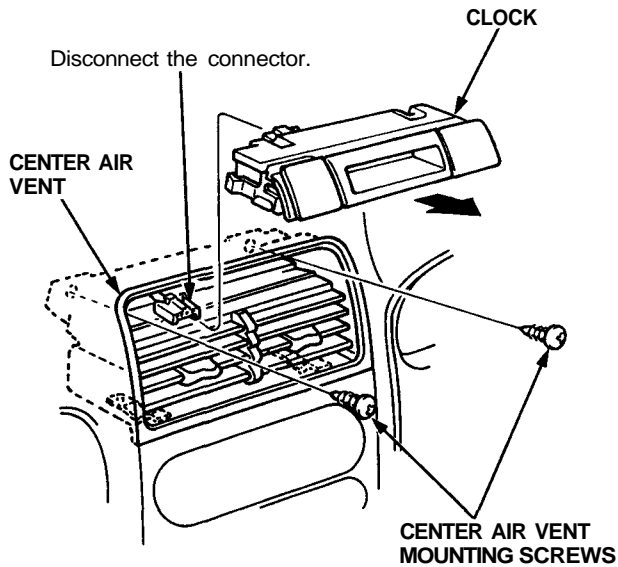

3. Inset a plastic plate between the center air vent and center console panel to prevent damage them.

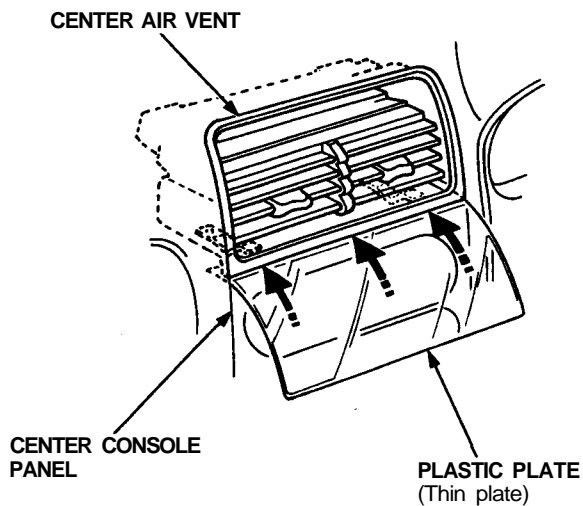

4. To make a gap between the center air vent and dashboard, pull the top of the center air vent while lowering it as shown.

NOTE: Make a gap thoroughly.

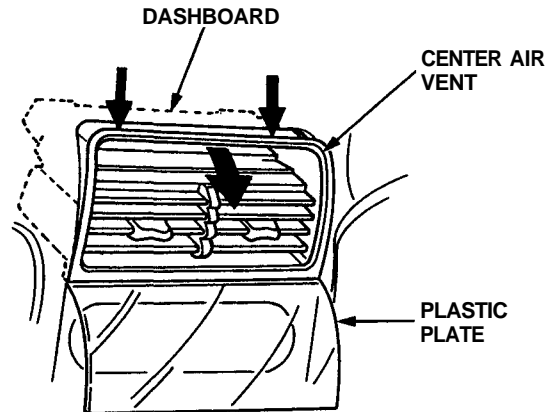

5. Inset a flat tip screwdriver between the center air vent and dashboard as shown.

NOTE: Use a flat tip screwdriver as following.

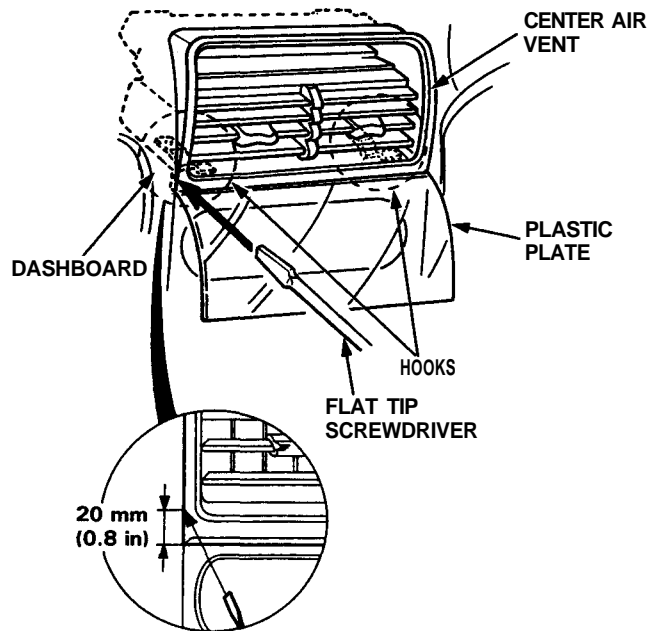
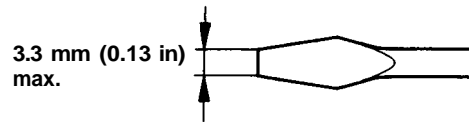



6. After inserting a flat tip screwdriver, turn it 90°.

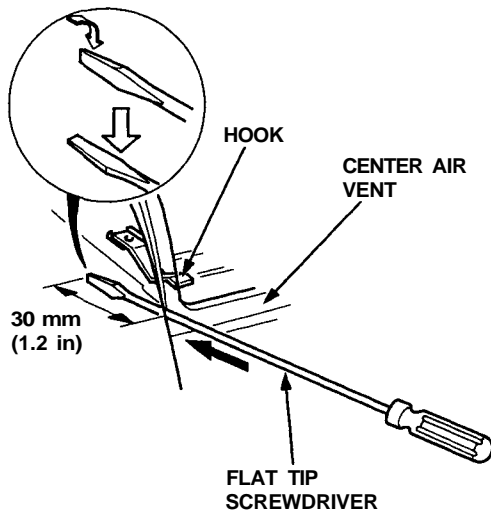

7. Inset the tip of a flat tip screwdriver in under the hook by turning a flat tip screwdriver. Detach the hook by prying it.

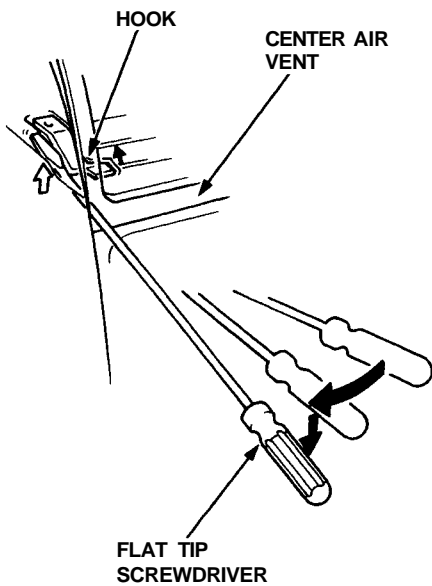

8. Pull the center air vent backward while prying the hook.

**CAUTION:** Use a shop towel on the dashboard to prevent damage.

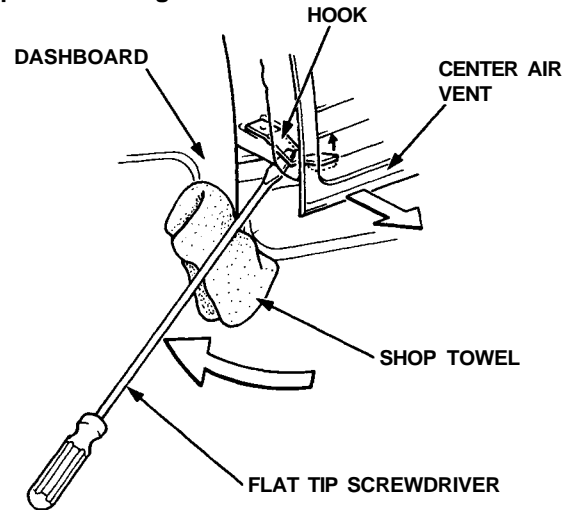

9. Detach the another hook as the same work, then remove the center air vent.

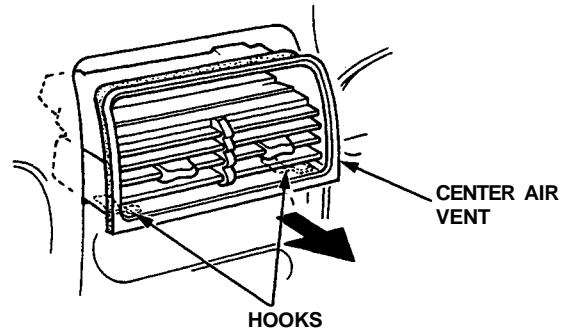

10. Install the center air vent and clock.

**NOTE:**

- If there is a minor dent on the dashboard, repair it by hand as shown.

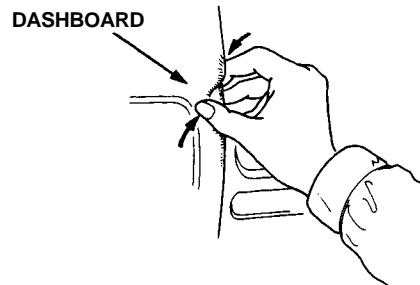

- Make sure the connector of the clock is connected properly.

(cont'd)

# Dashboard

## Component Removal/Installation (cont'd)

SRS wire harnesses are routed near the dashboard.

### CAUTION:

- All SRS wiring harnesses are covered with yellow outer insulation.
- Before disconnecting any part of the SRS wire harness, install the short connectors (see page 23-328).
- Replace the entire affected SRS harness assembly if it has an open circuit or damaged wiring.

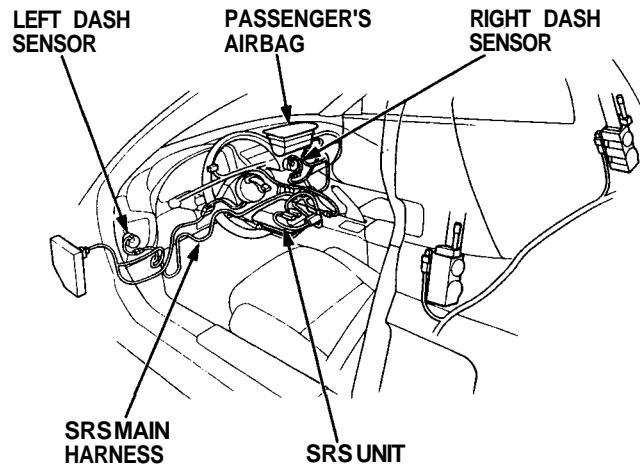

### Center console panel removal:

#### NOTE:

- Take care not to scratch the dashboard, center console panel and related parts.
- Do not drop the screws inside the dashboard.
- Remove the center armrest (see page 20-49), clock and center air vent (see page 20-50).

Disassemble in numbered sequence.

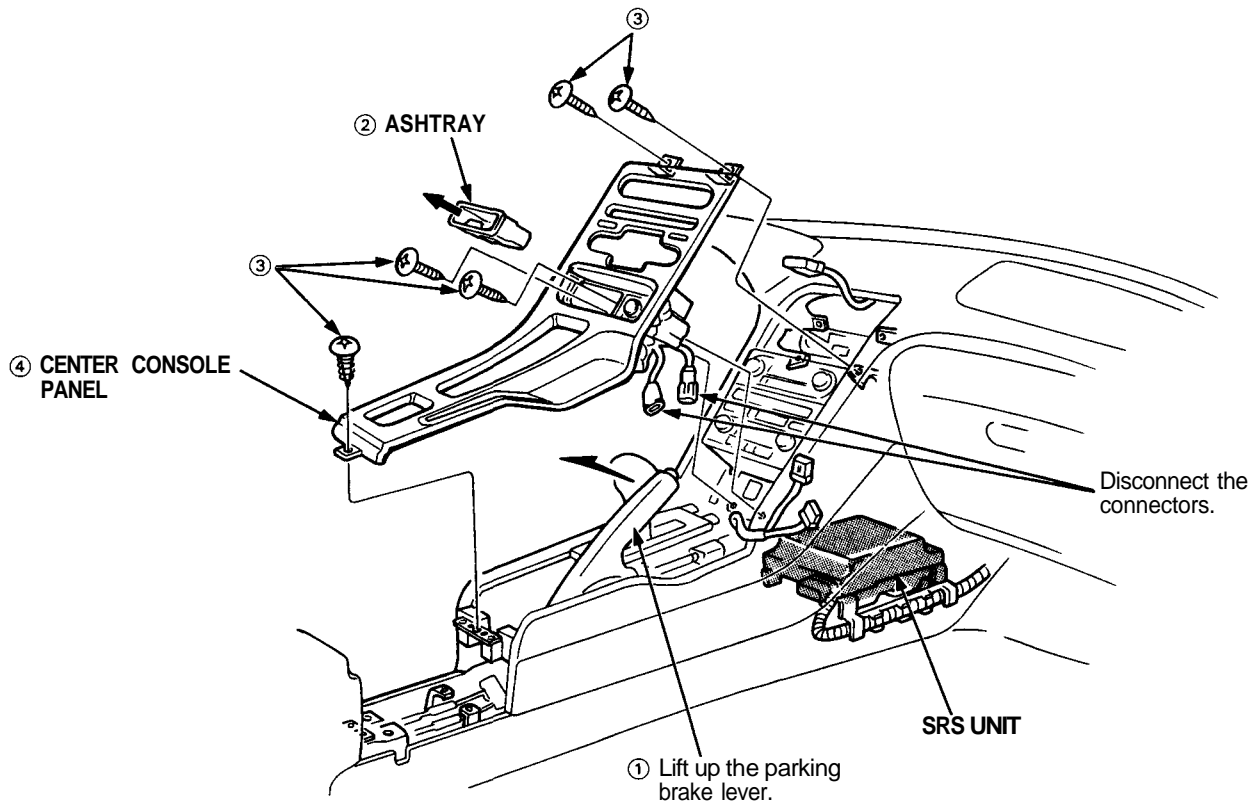

Installation is the reverse of the removal procedure.

NOTE: Make sure the connectors are connected properly.



**Climate control unit, stereo cassette/radio and glove box removal:**

Disassemble in numbered sequence.

NOTE: Remove the center console panel.

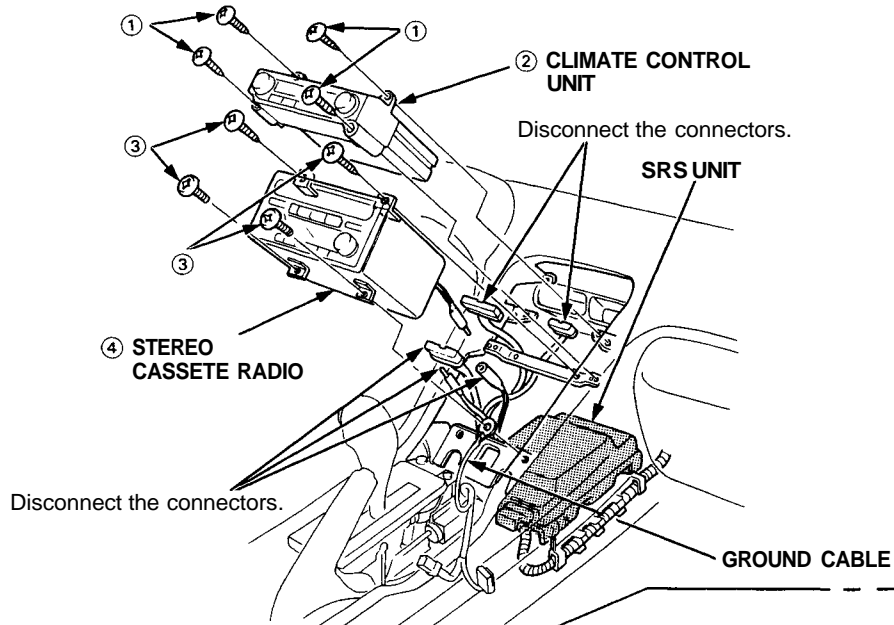

**Passenger's:**

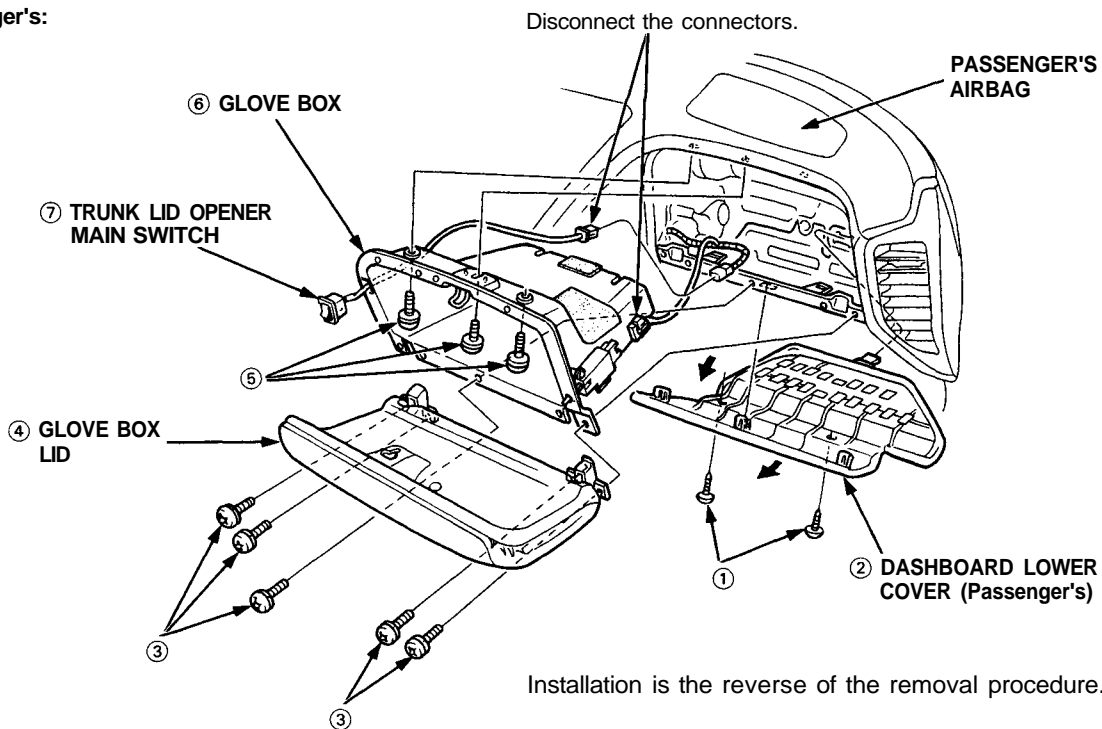

Installation is the reverse of the removal procedure.

NOTE: Make sure the connectors are connected properly.

(cont'd)

# Dashboard

## Component Removal/Installation (cont'd)

SRS wire harnesses are routed near the steering column.

### CAUTION:

- All SRS wiring harnesses are covered with yellow outer insulation.
- Before disconnecting any part of the SRS wire harness, install the short connectors (see page 23-328).
- Replace the entire affected SRS harness assembly if it has an open circuit or damaged wiring.

NOTE: Take care not to scratch the dashboard, steering column and related parts.

CAUTION: When prying with a flat tip screwdriver, wrap it with protective tape or a shop towel to prevent damage.

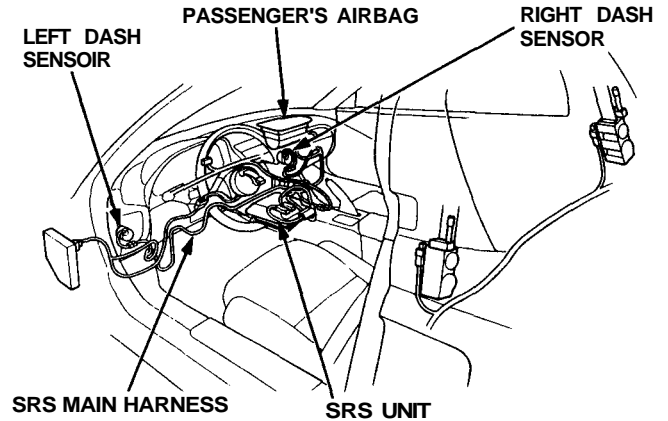

### Drivers:

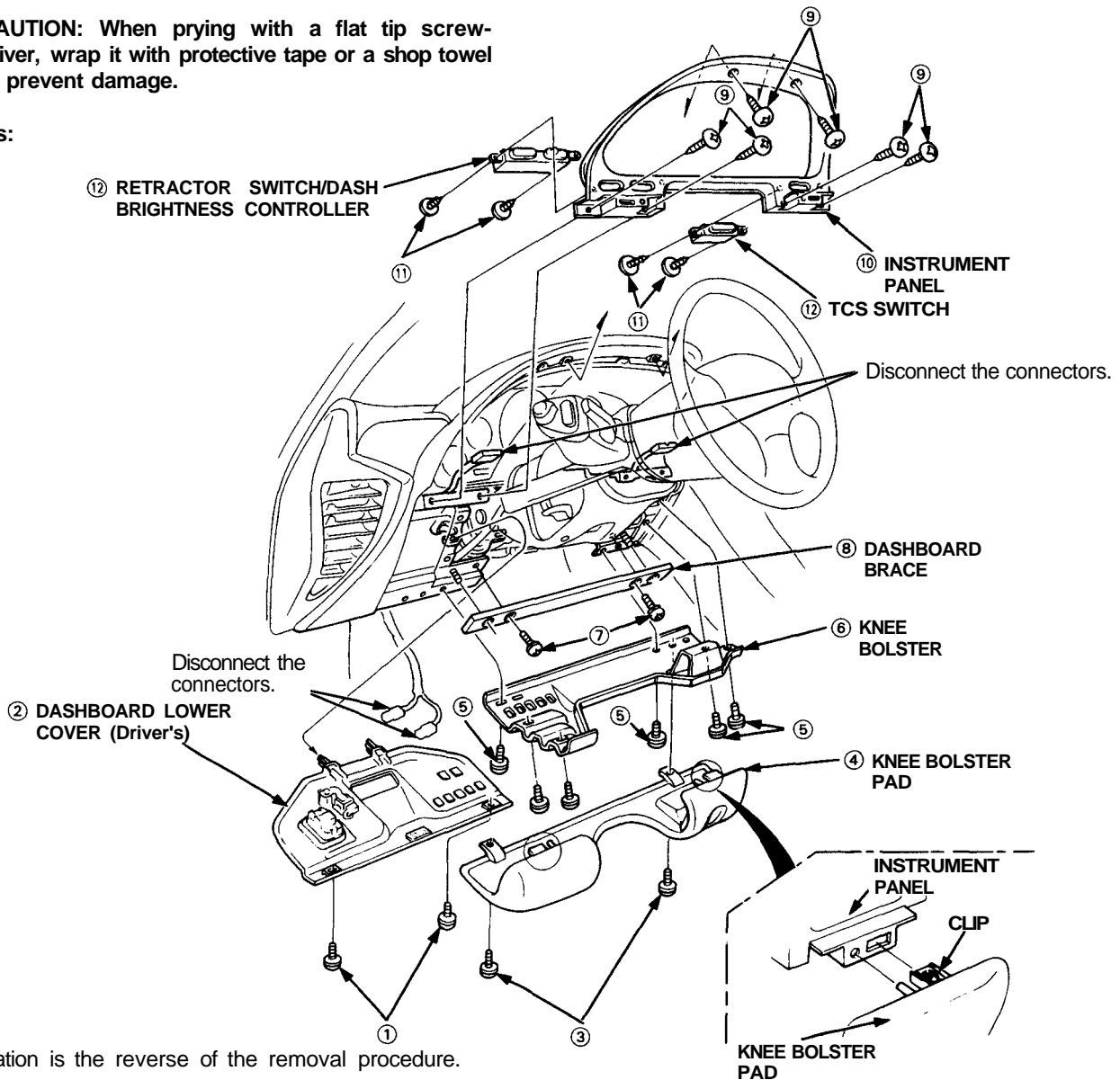

NOTE: Make sure the connectors are connected properly.