

# Wipers/Washers

## Windshield Wiper Motor Replacement

1. Open the hood and remove the cap nuts and the wiper arms. Don't let the wiper arms hit the hood.
2. Remove the windshield lower molding, hood seal and air scoop by prying off the trim clips and removing the screws (see page 23-293):
3. Disconnect the 5-P connector from the wiper motor assembly, then remove the two mounting bolts and the wiper linkage assembly.

WIPER LINKAGE ASSEMBLY

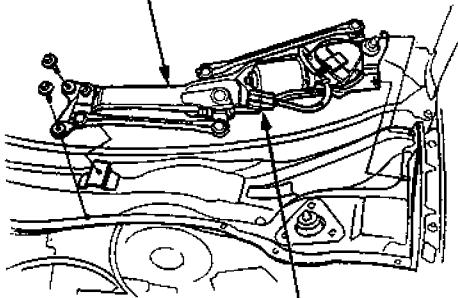

5-P CONNECTOR

4. Remove the three mounting bolts and nut from the wiper linkage assembly and remove the wiper motor.

NUT  
18 N·m(1.8 kg·m, 13 lb-ft)

MOUNTING  
BOLTS  
8 N·m (0.8 kg·m,  
5.8 lb-ft)

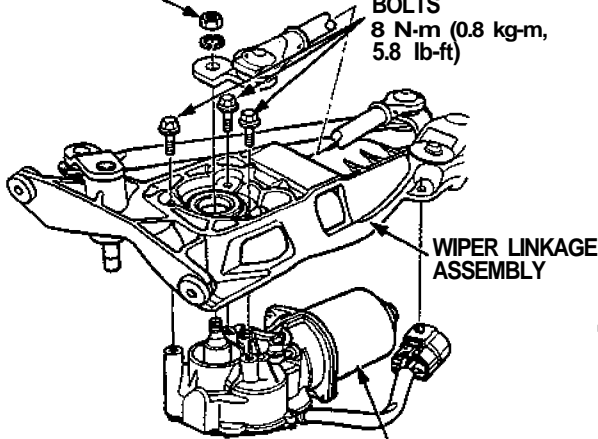

WIPER LINKAGE ASSEMBLY

WIPER MOTOR

5. Install the wiper motor assembly in the reverse order of removal.

## Windshield Wiper/Washer Switch — Replacement

### CAUTION:

- All SRS wiring harnesses are covered with yellow outer insulation.
- Before disconnecting any part of the SRS wire harness, install the short connectors (see page 24-10).
- Replace the entire affected SRS harness assembly if it has an open circuit or damaged wiring.

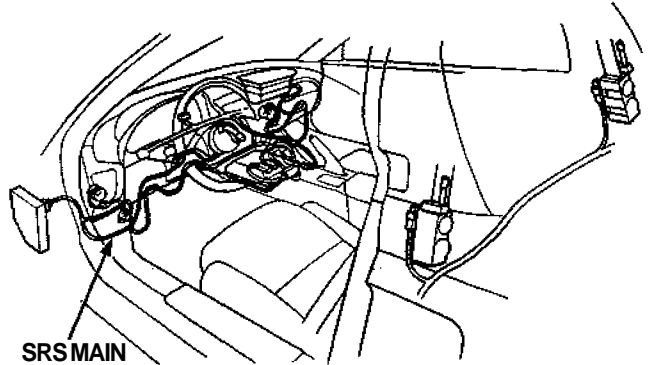

SRS MAIN HARNESS

1. Remove the dashboard lower cover and disconnect the connectors from the floor wire harness.

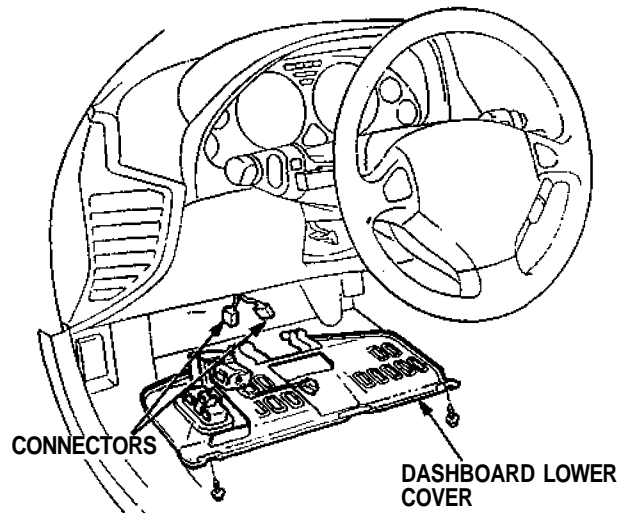

CONNECTORS

DASHBOARD LOWER COVER



2. Disconnect the 18-P connector from the floor wire harness.

**CAUTION:** Be careful not to damage the SRS wires.

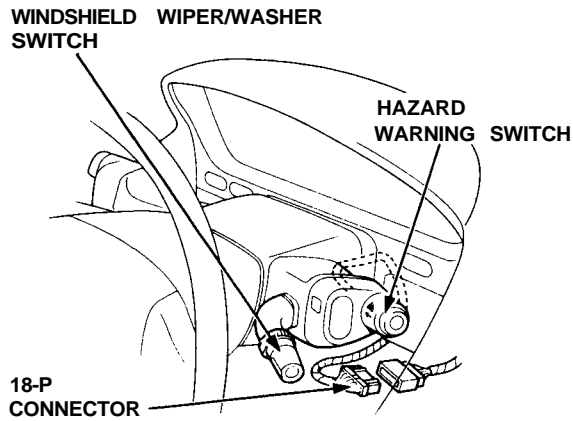

3. Remove the tilt cover.

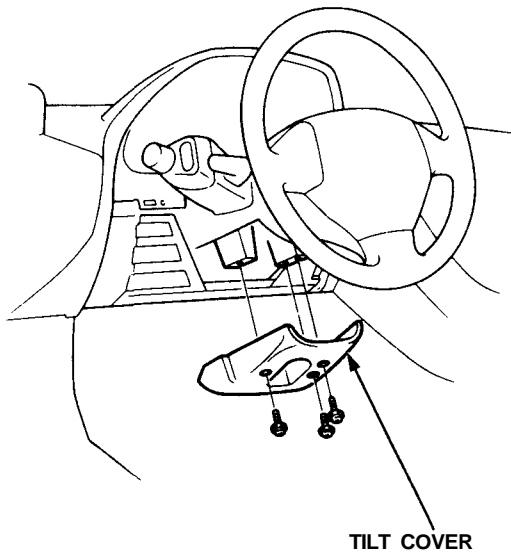

4. Carefully remove the steering column lower cover and upper cover.

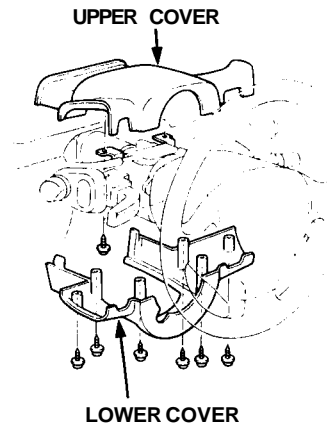

5. Remove the four screws, then remove the hazard warning switch and windshield wiper/washer switch assembly.

